



Planetary Roller Screw

High dynamic load capacity up to 1200 kN

High efficiency

High positional accuracy

Long life

Low maintenance

Low noise

3. **spiracon™ roller screws**

Power Jacks Group

South Harbour Road, Fraserburgh, Aberdeenshire, AB43 9BZ, Scotland, UK

tel: +44 (0) 1346 513131 fax: +44 (0) 1346 516827
email: sales@powerjacks.com web: www.powerjacks.com



Section Index



1. Screw Jacks (Mechanical Actuators)

Cubic Metric Machine Screw Actuators
Metric and Imperial Machine Screw Actuators
Stainless Steel Actuators - Metric and Imperial
Micro-Miniature Actuators
Ball Screw Actuators - Metric and Imperial
Roller Screw and Special Actuators



3. Screw Drives

Spiracon Roller Screw



5. Reduction Gearboxes

Helical Worm Gearboxes
In-Line Helical Gearboxes



7. Electric Motors

Standard 3-Phase Motors
Brake Motors
Motors with Encoders and Forced Ventilation



9. Engineers Reference

Formulae and Factors
Standard Metric Component Data
Properties
Warranty

2. Linear Actuators

EMA - Actuator Series
Rolaram Actuator Series



4. Bevel Gearboxes - Neeter Drive

P-Range Series 2000 and 4000
N-Range Series 35, 37, 38, 39 and 40
BA-Range Series L, H, and K



6. Couplings and Drive Shafts

Jaw and Gear Flexible Couplings
Drive Shafts
Plummer Blocks
Hand Wheels



8. Motion Control

Rotary Limit Switches
Proximity and Electro-mechanical Limit Switches
Encoders - Incremental and Absolute
Position Indicators
Control Panels



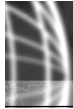

Picture Index



Cubic Actuators



Metric Actuators



Metric Ball Screw Actuators



Stainless Steel Actuators



EMA Actuators



Ball Screw Rolaram Actuator

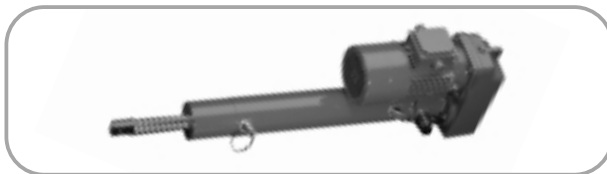

Roller Screw Rolaram Actuator



Special Actuators



Imperial Actuators



Imperial Ball Screw Actuators



Roller Screw and Special Actuators



Spiracon Roller Screw



P-Range Bevel Gearboxes



N-Range Bevel Gearboxes



BA-Range Bevel Gearboxes



Electric Motors



*Couplings and
Drive Shafts*



Helical Worm Gearboxes



In-Line Helical Gearboxes



*Proximity and Contact Limit
Switches*



Rotary Limit Switches



Encoders



Position Indicators



Engineers Reference

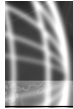

Company Profile

Power Jacks is the largest and most experienced manufacturer of actuators and mechanical jacks in the UK. With our range of Power Jacks and Duff-Norton actuators you don't just get the product, you also get the knowledge and experience from a company that has, since 1883, manufactured quality industrial lifting, positioning and materials handling equipment.

On our extensive site in Fraserburgh, Aberdeenshire, we have a wide range of engineering facilities including CAD/CAM/CAE technology to aid engineering design and manufacture, an advanced production control system ensuring the optimum product flow through our comprehensive range of conventional and CNC machining facilities, which maximises efficiency and reduces delivery times. This is achieved with our 100+ highly trained employees, giving Power Jacks the capability to produce mechanical engineering of the highest standards.

Quality is a key part of Power Jacks working philosophy and built into the product from initial design conception, through production, to installation and after sales service.

There are over two million of our actuators successfully in operation world-wide. The Power Jacks Group are a global market leader in Linear Actuation Systems.



Power Jacks Ltd Extensive Site in Fraserburgh, Aberdeenshire



By specifying a Power Jacks product you are assured of quality, reliability, performance and value. In the United Kingdom there are a team of highly experienced sales engineers to assist customers with their actuation applications whether on site or by direct communications with the Fraserburgh factory. For overseas customers there is an extensive distributor network world-wide.





Power Jacks Standard Product Range Covers:-

- Machine Screw Worm Gear Actuators (Screw Jacks)
- Ball Screw Actuators (Screw Jacks)
- Stainless Steel Actuators (Screw Jacks)
- Micro-Miniature Actuators
- TracMaster Electro-Mechanical Linear Actuators
- EMA Electro-Mechanical Linear Actuators
- Rolaram Electro-Mechanical Linear Actuators
- Mechanical Jacks
- Neeter Drive Bevel Gear Boxes
- Reduction Gear Boxes
- Power Transmissions
- Accessories for Complete Actuator Systems
- Actuator Motion Control Systems
- Track (Rail) Jacks
- Hydraulic Jacks
- Hydraulic Cylinders
- Hydraulic Pumps and Tools



Both Metric and Imperial Products are available.

As well as these standard products Power Jacks has a dedicated engineering team for the design of "Special" products to suit all customer requirements.

These products can be provided as individual parts or single or multiple systems with full engineering consultancy available as part of the service.

For more information contact:

Power Jacks Ltd
South Harbour Road Fraserburgh AB43 9BZ
Tel: +44 (0) 1346 513131
Fax: +44 (0) 1346 516827
email: sales@powerjacks.com
Internet: <http://www.powerjacks.com>



Company Profile

The Power Jacks Group is an engineering group focused on providing customers with the best solution for precision linear actuation, power transmission, mechanical jacking, hydraulic jacking and engineering service. The engineering history of the group dates from 1883 and the products and service are supplied to customers world-wide.

The Power Jacks Group Brings Together

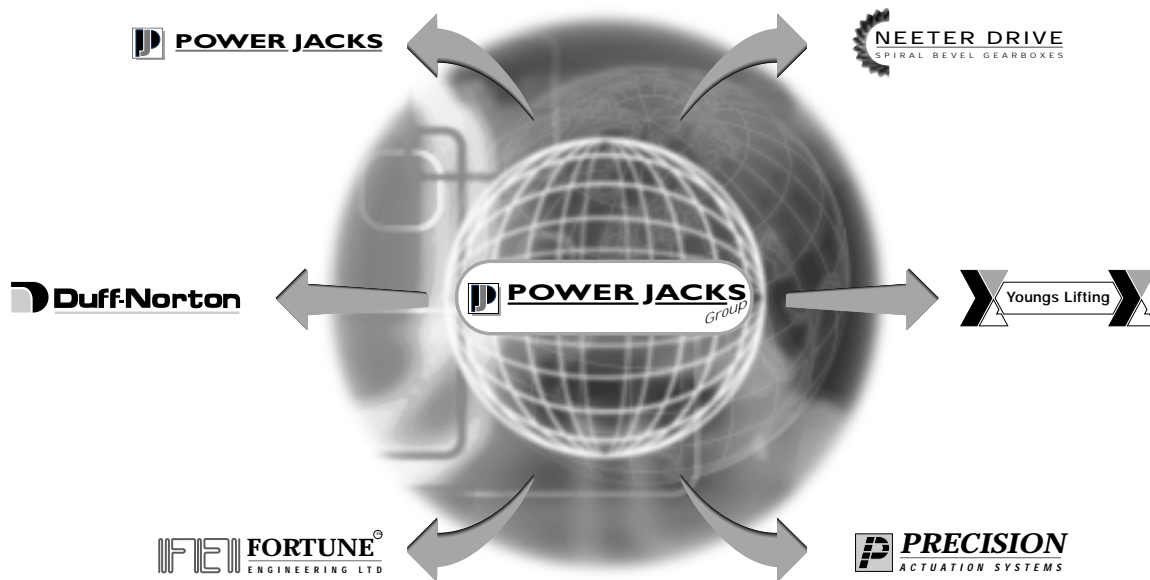

Representation





Contents

3.	Screw Drives	
3.1.	Spiracon™ Roller Screw	2
3.1.1.	Spiracon™ Roller Screw Overview	2
3.1.2.	Working Applications for Spiracon™ Roller Screws	4
3.1.3.	Spiracon™ Roller Screw Product Code	5
3.1.4.	Spiracon™ Roller Screw Range	6
3.1.5.	How to Select a Spiracon™ Roller Screw	7
3.1.6.	Spiracon™ Roller Screw Technical Data and Dimension	10



3.1. Spiracon™ Roller Screw

3.1.1. Spiracon™ Roller Screw Overview

Spiracon™ is a planetary roller screw, which converts rotary motion to linear movement. It is a unique concept, invented and patented by Illinois Tool Works, USA, and developed by and licensed solely to Power Jacks Ltd.

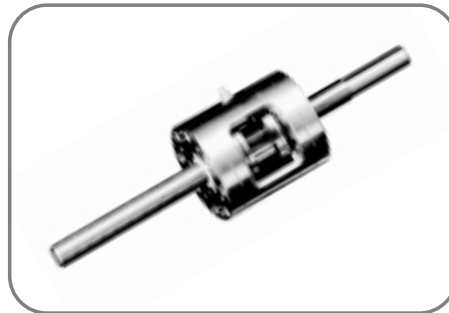

Principle of Operation

The Spiracon™ system consists of a multi-start screw with an involute thread form and a number of planetary rollers with annular grooves, which engage with the screw. These rollers also engage with a grooved load bearing element, which transmits the load through roller thrust bearings, to the nut housing. The rolling action results in a high efficiency mechanism, while the line contact and hardened and ground construction achieves a high dynamic load carrying capacity, together with almost no axial backlash or wear.

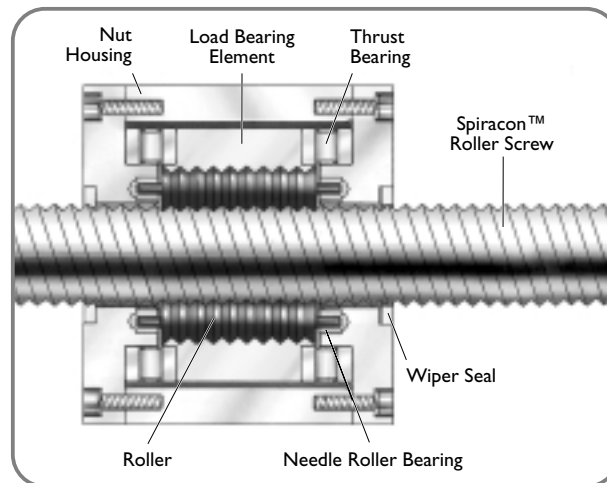

Main Features of Spiracon™ Roller Screws

- High dynamic load capacity
- High efficiency
- High positional accuracy
- Long life and low maintenance
- Same nut fits both right and left handed screws
- Hardened and ground rolling elements
- Clean operation
- Low noise.



Advantage over Ball Screws

- Higher dynamic load capacity
- Larger diameters and higher leads
- Higher positional accuracy
- Longer life
- Higher stiffness
- Higher speed and acceleration
- Low temperature operation
- Lower noise
- Nut easily removed with rollers retained
- Higher safety.

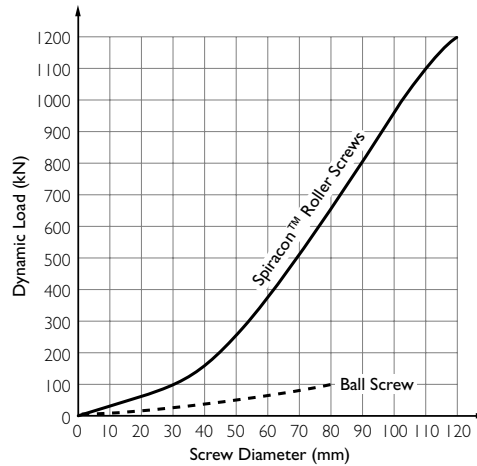

Applications for Spiracon™ Roller Screws

Spiracon™ roller screws are well proven throughout the world in a wide variety of industries including:

- Nuclear
- Aerospace
- Metal processing
- Medical
- Automotive
- Food Processing
- Paper
- Offshore and marine
- Communications
- Defence

Typical applications include:

- Robotics
- Laser tracking
- Indexing/adjusting
- Simulators
- Seismic testing
- Shield door adjustment
- Machine Tools
- Antenna dish adjustment
- Clamping mechanisms
- Medical scanners
- Continuous casting . . .

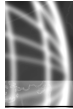

3.1.2. Applications for Spiracon™ Roller Screws

Application Anti-sway mechanism on ship-to-shore container cranes in Hong Kong.

Linear Actuation Requirements All 4 screws and nuts required to be synchronised. High loads and an aggressive marine environment were also factors.

Solution Four model 65 mm Spiracon™ roller screws (2 left hand and 2 right hand) with associated bevel gearboxes, couplings and shafting, per crane.



Application Flying shear for cutting to length pre-formed steel sheets.

Linear Actuation Requirements The shear required to be operated continuously and accurate repeatability of positioning was important. Long life and low maintenance were necessary.

Solution Model 55 mm Spiracon™ roller screw operating on a continuous reversal basis.

Application Clamping machine for reclamation of steel rolls.

Linear Actuation Requirements High dynamic load requirement, reliability of operation and a demanding operating environment.

Solution Model 75 mm Spiracon™ roller screw operating a vertical clamp, to hold steel rolls in position.

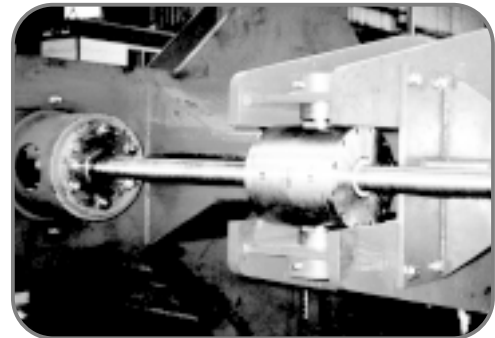

Application Road bridge inspection and maintenance platforms.

Linear Actuation Requirements Safety was the overriding requirement, as human cargo was involved. The units would be subjected to high load requirements and hostile weather conditions.

Solution Two 15 tonne platforms, raised and lowered by model 75 mm Spiracon™ roller screws, fitted with disk brakes and mechanical stops as safety features.



3.1.4. Spiracon™ Roller Screw Range

There are 10 standard Spiracon™ roller screw models, with diameters from 15 mm to 120 mm, each with a choice of 3 leads. Dynamic load capacities of over 1000 kN (100 tonnes) and linear speeds of over 30 m/min are possible.

Where the standard range does not meet the application specification, special roller screws can be designed to meet customers' specific requirements (see Specials section below).

3.1.4.1. Efficiency

The Spiracon™ roller screw has an efficiency of typically 85%. Power consumption is therefore minimised, and a compact screw system is possible. Such a high efficiency means that the screw is not self-sustaining, and a braking system is needed to prevent back driving.

3.1.4.2. Tolerancing

The highly accurate machining and assembly of each roller screw means total axial play of less than 0.01mm can be achieved. The cumulative pitch error in the screw is typically less than 0.005 mm per 300 mm. Combined with a high stiffness, this means that accurate and repeatable positioning is possible. The screw straightness is within 0.1 : 1000.

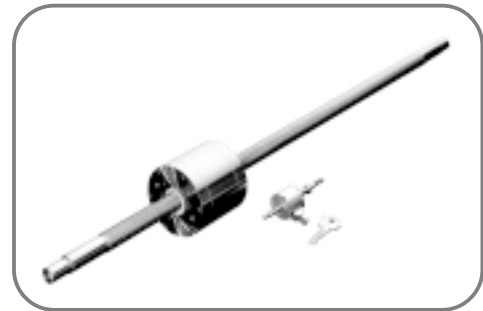

3.1.4.3. Operating Life

Operating life is dependent upon the dynamic load. The maximum dynamic loads shown in the Technical Chart (Refer 3.1.6.) are equivalent to 1000000 revolutions of the screw. To determine actual operating life, please refer to "How to select a Spiracon™ Roller Screw" in Section 3.1.5. Where severe operating conditions exist, please consult our Technical Sales Department.

3.1.4.4. Guiding the Load

Loads should be guided, to remove any possible side load from the Spiracon™ nut. The guide system will also resist the torque developed by the roller screw mechanism.

3.1.4.5. Mounting

The Spiracon™ nut can be mounted using the standard mounting holes and location diameter. Screw end machining to suit thrust bearings is provided, or this can be specified to suit customer requirements. Mounting for operation in any orientation is possible.

3.1.4.6. Screw Length

The screw length is determined by the load and speed conditions (please refer to Step 2 of How to Select a Spiracon™ Roller Screw, Section 3.1.5.). For total screw lengths greater than shown in the table right, please consult our Technical Sales Department.

Screw Diameter	Maximum Length
Up to 20 mm	2 metres
30 mm to 90 mm	6 metres
120 mm	3 metres

3.1.4.7. Operating Environment

All units are constructed and finished to suit industrial operating conditions. Normal operating temperatures are from -10°C to +50°C. However, Power Jacks products have been proven in very low operating temperatures (-30°C - Arctic) and in higher temperatures (+70°C - steelworks). Wiper seals prevent the entry of large particles into the nut mechanism, and bellows can be provided to protect the screw. Please contact our Technical Sales Department to discuss hostile or hazardous operating environments.

3.1.4.8. Lubrication and Maintenance

Spiracon™ roller screws require only a minimum of maintenance during the normal operating life. Depending upon the duty, periodic lubrication should be carried out using Rocol MTS 1000 grease, through the nipple provided.

3.1.4.9. Specials

Spiracon™ can be offered to suit "special" applications, requiring for example:

- Special screw diameters or leads.
- Left hand screw threads.
- Very high dynamic load (over 1000 kN).
- Special materials e.g stainless steel.
- Temperature extremes or hazardous environments.
- Special screw end machining or nut mounting e.g. trunnions.



3.1.5. How to Select a Spiracon™ Roller Screw

There are 3 simple steps as follows :

Step 1 Load, Speed and Life

From the Technical Chart in Section 3.1.6., make an initial selection of a Spiracon model to suit the required maximum dynamic and static loads.

Model	Lead	Pitch	Dynamic C (kN)	Static Co (kN)	AØ	NUT		
						B	CØ	H6
15	6	1	45	68	92	90	34	4
	12	2	35	52	92	90	34	4
20	6	1	58	87	103	110	45	4
	12	2	58	87	103	110	45	4
	18	3	50	74	103	110	45	4

Full table in 3.1.6.

Choose a screw lead and calculate the rotational speed to suit the required linear speed:

$$\text{Rotational speed} = \frac{\text{Linear speed (mm/minute)}}{\text{Screw lead (mm)}}$$

Check that the rotational speed is below the maximum speed shown in the Technical Chart for the model selected.

Calculate the total number of revolutions of the screw for the operating life required:

$$\text{Required no. of screw revs.} = \text{Life (hours)} \times \text{Rotational speed (rpm)} \times 60$$

Check the operating life for the selected Spiracon model:

C = Dynamic capacity (kN) from Technical Chart

F = Application dynamic load (kN) (or Fm, mean load as below)

$$\text{Actual no. of screw revs.} = \left(\frac{C}{F}\right)^{3.33} \times 10^6$$

$$\bullet \text{ Actual life in hours} = \frac{\text{No. of screw revs.}}{\text{Rotational speed} \times 60}$$

If required, reiterate the calculation to achieve the required life.

Where the dynamic load varies, the mean load (Fm) can be approximated as follows:

$$F_m = \sqrt[3]{\frac{(F_1^3 \times U_1) + (F_2^3 \times U_2) + \dots}{U}}$$

F1, F2 = constant loads during U1, U2 revolutions

U = total number of revolutions

Where the dynamic load varies between a minimum (Fmin) and maximum (Fmax) the mean load is :

$$F_m = \frac{F_{min} + 2 \times F_{max}}{3}$$

Step 2 Critical Speed, Buckling and Deflection

Establish length (L) based on the required stroke and bearing support conditions. For length (L), check that the rotational speed is below the critical speed limit, given by the formula:

$$\text{Critical speed limit (rpm)} = \frac{10^7 \times f_1 \times J}{L^2}$$

Where f1, f2 and f3 are defined by the bearing support conditions shown in the diagram overleaf, and J is the root diameter of the Spiracon™ thread given in the Technical Chart in section 3.1.6.

Where the screw is under a compression load, check that the chosen screw diameter and length (L) are within the load limit for buckling, given by the formula:

$$\text{Load limit (N)} = \frac{10^4 \times f_2 \times J^4}{L^2}$$

For long horizontal screws, check the deflection of the screw under its own weight:

$$\text{Deflection (mm)} = \frac{6 \times 10^{-9} \times L^4}{f_3 \times J^2}$$



Bearing Support Conditions

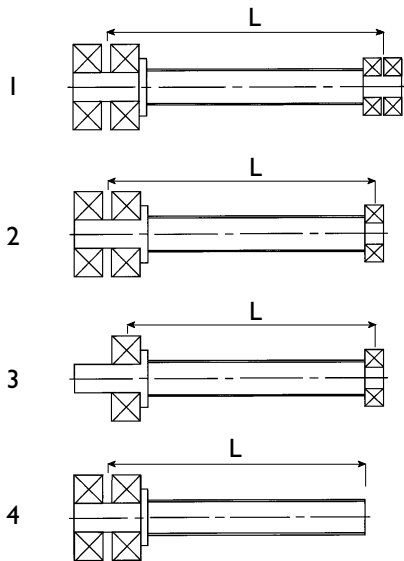

f1	f2	f3
21	12.5	384
15	6.5	185
9.5	3	77
3.4	0.8	8

Step 3 Torque and Power

Calculate the torque required to drive the screw:

$$\text{Torque (Nm)} = \frac{\text{Dynamic load (N)} \times \text{Lead (mm)}}{2000 \times \pi \times \text{Efficiency (0.85)}}$$

$$\text{Power (kW)} = \frac{\text{Torque (Nm)} \times \text{Rotational speed (rpm)}}{9550}$$

Note: Where there is a high acceleration or inertia, please consult our Technical Sales Department.



3.1.5. How to Select a Spiracon™ Roller Screw

Example

Select a standard right hand Spiracon screw and nut for the following:

- Dynamic load = 220 kN (in compression)
- Linear speed = 900 mm/minute
- Required life = 2000 hours
- Required stroke = 1200 mm
- Overall screw length = 1850 mm
- Screw mounting = Vertical
- Bearing support condition = 2

Step 1

From the chart in section 3.1.6., make initial selection of:

Model 65 x 36 lead

Select a lead of 36mm to give a rotational speed of:

$$\frac{900}{36} = 25 \text{ rpm (OK} < 1700 \text{ rpm)}$$

Calculate the number of revolutions of the screw to give the required life:

$$\text{Required no. of screw revs.} = 2000 \times 25 \times 60 = 3 \times 10^6$$

Check the operating life for selected Spiracon model:

$$\begin{aligned} \text{Actual no. of screw revs.} &= \frac{310^{3.33}}{220} \times 10^6 \\ &= 3.14 \times 10^6 \text{ (OK} > 3 \times 10^6) \\ \bullet \text{ Actual life in hours} &= \frac{3.14 \times 10^6}{25 \times 60} = 2093 \text{ hours} \\ &\text{(OK} > 2000 \text{ hours)} \end{aligned}$$

Step 2

- Stroke = 1200 mm
- Length (L) = 1600 mm
(refer bearing support condition)

Check the critical speed limit:

$$\begin{aligned} \text{Speed limit (rpm)} &= \frac{10^7 \times 10 \times 63.7}{1600^2} \\ &= 2488 \text{ rpm (OK} > 25 \text{ rpm)} \end{aligned}$$

Check for buckling of the screw:

$$\begin{aligned} \text{Load limit (N)} &= \frac{10^4 \times 6.5 \times 63.7^4}{1600^2} \\ &= 418 \text{ kN (OK} > 220 \text{ kN)} \end{aligned}$$

Step 3

The torque and power are:

$$\begin{aligned} \text{Torque (Nm)} &= \frac{220000 \times 36}{2000 \times \pi \times 0.85} = 1483 \text{ Nm} \\ \text{Power (kW)} &= \frac{1483 \times 25}{9550} = 3.88 \text{ kW} \end{aligned}$$

• The complete product code is SPT-065-36-6-RH-1850-1500-1-0 (refer 3.1.3. for full breakdown of this code)

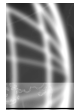

3.1.6. Spiracon™ Roller Screw Technical Data and Dimensions

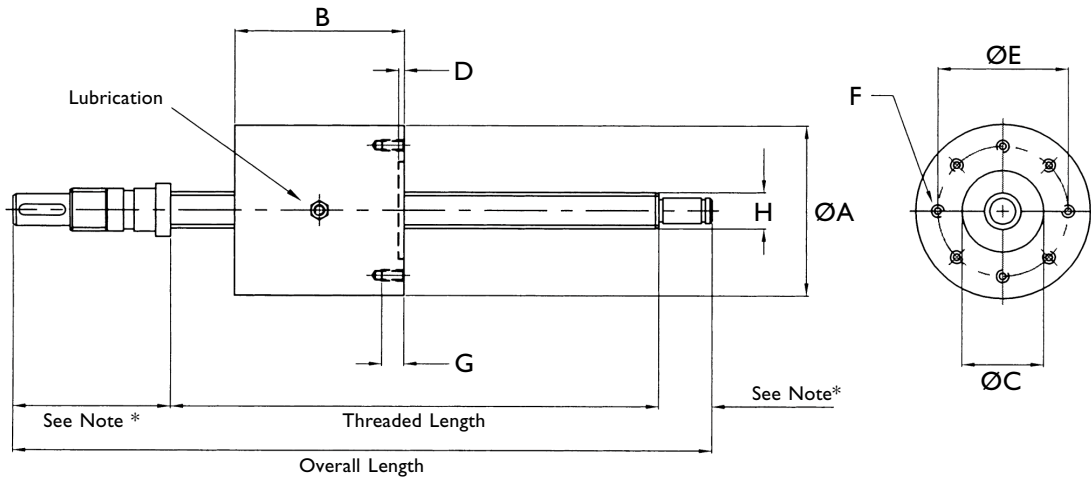

Note: * = Customer to define at time of ordering.
 Øj = Root diameter of Roller screw

Technical Dimensional Chart

(all dimensions are in millimetres)

Model	Lead	Pitch	Dynamic C (kN)	Static Co (kN)	NUT							SCREW				WEIGHTS	
					AØ	B	CØ H6	D	E PCD	F Dia x No	G	HØ	JØ min	Max Speed (rpm)	Nut (kg)	Screw per 100 mm (kg)	
15	6	1	45	68	92	90	34	4	55	M8 X 6	12	17	15.3	5500	3.5	0.18	
	12	2	35	52	92	90	34	4	55	M8 X 6	12	17	15.3	5500	3.5	0.18	
20	6	1	58	87	103	110	45	4	58	M8 X 8	12	21	18.4	4900	5.5	0.27	
	12	2	58	87	103	110	45	4	58	M8 X 8	12	21	18.4	4900	5.5	0.27	
	18	3	50	74	103	110	45	4	58	M8 X 8	12	21	18.4	4900	5.5	0.27	
30	6	1	100	150	125	130	50	4	70	M10 X 8	15	30.8	28.2	4300	9.3	0.55	
	18	3	90	120	125	130	50	4	70	M10 X 8	15	30.8	28.2	4300	9.3	0.55	
	24	3	105	150	125	130	50	4	70	M10 X 8	15	30.8	28.2	4300	9.3	0.55	
40	12	2	120	180	135	135	65	4	83	M12 X 8	18	39	35.5	3300	11.0	0.92	
	24	3	128	192	135	135	65	4	83	M12 X 8	18	39	35.5	3300	11.0	0.92	
	32	4	115	172	135	135	65	4	83	M12 X 8	18	39	35.5	3300	11.0	0.92	
45	12	2	190	285	170	180	75	5	105	M16 X 8	24	46.6	41.3	2600	23.2	1.3	
	24	4	170	255	170	180	75	5	105	M16 X 8	24	46.6	41.3	2600	23.2	1.3	
	48	6	120	180	170	180	75	5	105	M16 X 8	24	46.6	41.3	2600	23.2	1.3	
55	12	2	290	435	205	229	85	5	128	M20 X 8	30	56.1	50.9	2100	44.0	1.92	
	24	4	270	405	205	229	85	5	128	M20 X 8	30	56.1	50.9	2100	44.0	1.92	
	48	6	275	410	205	229	85	5	128	M20 X 8	30	56.1	50.9	2100	44.0	1.92	
65	24	4	340	500	240	250	95	5	150	M20 X 8	30	68.8	63.7	1700	66.50	2.83	
	36	6	310	465	240	250	95	5	150	M20 X 8	30	68.8	63.7	1700	66.50	2.83	
	54	6	310	455	240	250	95	5	150	M20 X 8	30	68.8	63.7	1700	66.50	2.83	
75	24	4	380	570	275	260	105	6	165	M20 X 8	30	75.2	70.1	1600	87.4	3.45	
	36	6	340	510	275	260	105	6	165	M20 X 8	30	75.2	70.1	1600	87.4	3.45	
	54	6	340	510	275	260	105	6	165	M20 X 8	30	75.2	70.1	1600	87.4	3.45	
90	24	4	530	795	315	310	120	8	200	M24 X 10	35	90	85	1200	137	4.96	
	36	6	520	780	315	310	120	8	200	M24 X 10	35	90	85	1200	137	4.96	
	54	6	615	920	315	310	120	8	200	M24 X 10	35	90	85	1200	137	4.96	
120	24	4	950	425	420	400	150	8	250	M24 X 12	50	120	115	1000	310	8.82	
	40	5	1200	1800	420	400	150	8	250	M24 X 12	50	120	115	1000	310	8.82	
	54	6	1200	1800	420	400	150	8	250	M24 X 12	50	120	115	1000	310	8.82	

Dimensions subject to change without notice.