



2, 4, 6 or 8 Pole

220 → 240 VAC / 380 → 415 VAC → 3 Phase

50/60 Hz

Foot (B3), Flange (B5) or Face (B14) mounting

IEC Frames 63 → 200 as standard

Enclosure IP54 → 55 or higher

DC or AC Type Brakes

Encoder options

Forced ventilation

Power ratings up to 30 kW as standard

## 7. electric **motors**

### **Other Motors**

**Power Jacks can supply Electric Motors for all applications whether AC or DC Motors including:**

3-Phase AC with or without brake to EFF 1 or EFF 2

1-Phase AC capacitor start/induction run or capacitor start/capacitor run

1-Phase AC with brake

DC Permanent Magnet Motors (with or without brake)

DC Servo Motors (with or without brake and feedback devices)

Marine Motors

Hazardous Area Motors (including ATEX)

Aluminium, cast iron or steel housings

NEMA and Japanese standard Motors

Integral AC Inverter (option of local controls)

Tropicalised Motors

### **Power Jacks Group**

South Harbour Road, Fraserburgh, Aberdeenshire, AB43 9BZ, Scotland, UK

tel: +44 (0) 1346 513131

fax: +44 (0) 1346 516827

email: [sales@powerjacks.com](mailto:sales@powerjacks.com)

web: [www.powerjacks.com](http://www.powerjacks.com)



Section Index



**1. Screw Jacks (Mechanical Actuators)**

Cubic Metric Machine Screw Actuators  
Metric and Imperial Machine Screw Actuators  
Stainless Steel Actuators - Metric and Imperial  
Micro-Miniature Actuators  
Ball Screw Actuators - Metric and Imperial  
Roller Screw and Special Actuators



**3. Screw Drives**

Spiracon Roller Screw



**5. Reduction Gearboxes**

Helical Worm Gearboxes  
In-Line Helical Gearboxes



**7. Electric Motors**

Standard 3-Phase Motors  
Brake Motors  
Motors with Encoders and Forced Ventilation



**9. Engineers Reference**

Formulae and Factors  
Standard Metric Component Data  
Properties  
Warranty

**2. Linear Actuators**

EMA - Actuator Series  
Rolaram Actuator Series



**4. Bevel Gearboxes - Neeter Drive**

P-Range Series 2000 and 4000  
N-Range Series 35, 37, 38, 39 and 40  
BA-Range Series L, H, and K

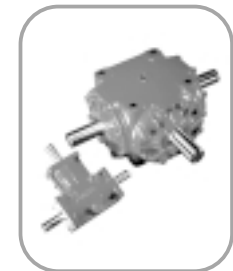

**6. Couplings and Drive Shafts**

Jaw and Gear Flexible Couplings  
Drive Shafts  
Plummer Blocks  
Hand Wheels



**8. Motion Control**

Rotary Limit Switches  
Proximity and Electro-mechanical Limit Switches  
Encoders - Incremental and Absolute  
Position Indicators  
Control Panels



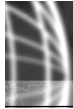

**Picture Index**



*Cubic Actuators*



*Metric Actuators*



*Metric Ball Screw Actuators*



*Stainless Steel Actuators*



*EMA Actuators*



*Ball Screw Rolaram Actuator*

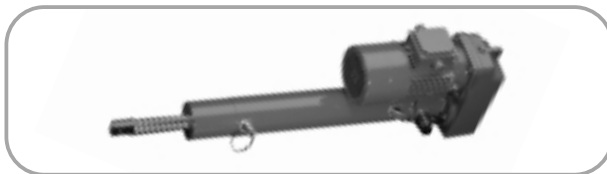

*Roller Screw Rolaram Actuator*



*Special Actuators*



*Imperial Actuators*



*Imperial Ball Screw Actuators*



*Roller Screw and Special Actuators*



*Spiracon Roller Screw Actuators*



*P-Range Bevel Gearboxes*



*N-Range Bevel Gearboxes*



*BA-Range Bevel Gearboxes*



*Electric Motors*



*Couplings and Drive Shafts*

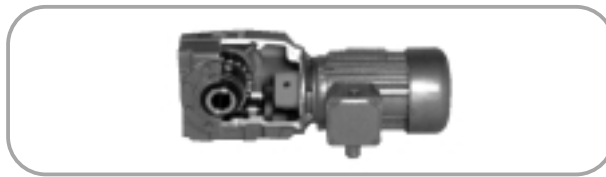

*Helical Worm Gearboxes*



*In-Line Helical Gearboxes*



*Proximity and Contact Limit Switches*



*Rotary Limit Switches*



*Encoders*



*Position Indicators*



*Engineers Reference*

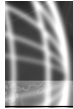

## Company Profile

Power Jacks is the largest and most experienced manufacturer of actuators and mechanical jacks in the UK. With our range of Power Jacks and Duff-Norton actuators you don't just get the product, you also get the knowledge and experience from a company that has, since 1883, manufactured quality industrial lifting, positioning and materials handling equipment.

On our extensive site in Fraserburgh, Aberdeenshire, we have a wide range of engineering facilities including CAD/CAM/CAE technology to aid engineering design and manufacture, an advanced production control system ensuring the optimum product flow through our comprehensive range of conventional and CNC machining facilities, which maximises efficiency and reduces delivery times. This is achieved with our 100+ highly trained employees, giving Power Jacks the capability to produce mechanical engineering of the highest standards.

Quality is a key part of Power Jacks working philosophy and built into the product from initial design conception, through production, to installation and after sales service.

There are over two million of our actuators successfully in operation world-wide. The Power Jacks Group are a global market leader in Linear Actuation Systems.



### *Power Jacks Ltd Extensive Site in Fraserburgh, Aberdeenshire*



By specifying a Power Jacks product you are assured of quality, reliability, performance and value. In the United Kingdom there are a team of highly experienced sales engineers to assist customers with their actuation applications whether on site or by direct communications with the Fraserburgh factory. For overseas customers there is an extensive distributor network world-wide.





**Power Jacks Standard Product Range Covers:-**

- Machine Screw Worm Gear Actuators (Screw Jacks)
- Ball Screw Actuators (Screw Jacks)
- Stainless Steel Actuators (Screw Jacks)
- Micro-Miniature Actuators
- TracMaster Electro-Mechanical Linear Actuators
- EMA Electro-Mechanical Linear Actuators
- Rolaram Electro-Mechanical Linear Actuators
- Mechanical Jacks
- Neeter Drive Bevel Gear Boxes
- Reduction Gear Boxes
- Power Transmissions
- Accessories for Complete Actuator Systems
- Actuator Motion Control Systems
- Track (Rail) Jacks
- Hydraulic Jacks
- Hydraulic Cylinders
- Hydraulic Pumps and Tools



Both Metric and Imperial Products are available.

As well as these standard products Power Jacks has a dedicated engineering team for the design of "Special" products to suit all customer requirements.

These products can be provided as individual parts or single or multiple systems with full engineering consultancy available as part of the service.

For more information contact:

**Power Jacks Ltd**  
South Harbour Road Fraserburgh AB43 9BZ  
Tel: +44 (0) 1346 513131  
Fax: +44 (0) 1346 516827  
email: [sales@powerjacks.com](mailto:sales@powerjacks.com)  
Internet: <http://www.powerjacks.com>



## Company Profile

The Power Jacks Group is an engineering group focused on providing customers with the best solution for precision linear actuation, power transmission, mechanical jacking, hydraulic jacking and engineering service. The engineering history of the group dates from 1883 and the products and service are supplied to customers world-wide.

### The Power Jacks Group Brings Together

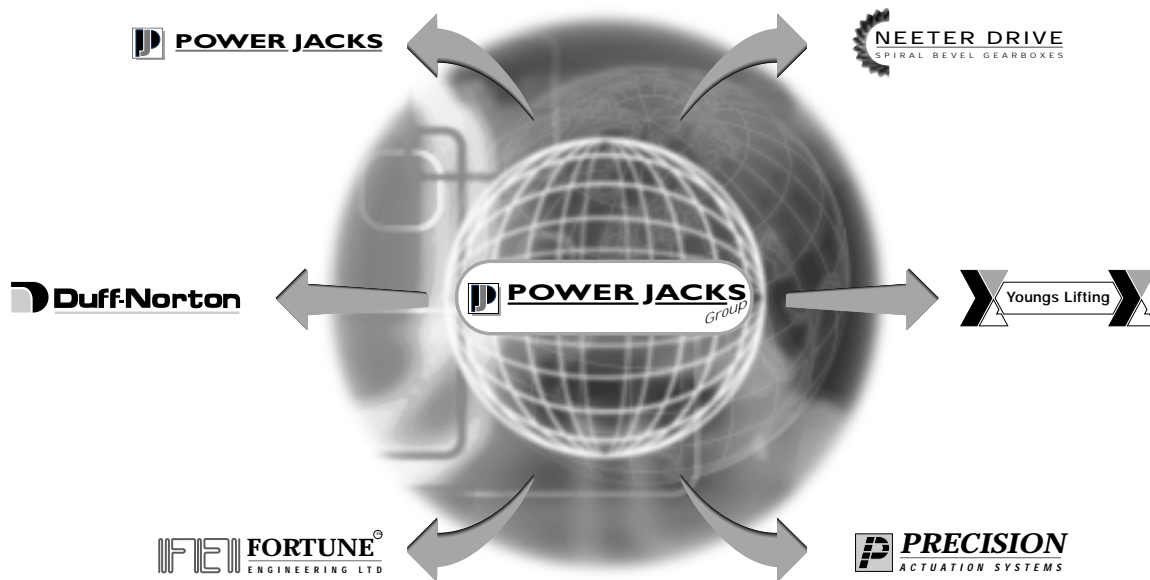

### Representation





## Contents

<b>7.1.</b>	<b>Electric Motors</b>	<b>2</b>
	7.1.1. AC Motors	2
	7.1.2. AC Motor Performance - 1500 rpm (4 pole)	2
	7.1.3. AC Motor Performance - 1000 rpm (6 pole)	3
	7.1.4. AC Motors with Integral Encoders	3
	7.1.5. AC Motors with Forced Ventilation	3
	7.1.6. Motor Dimensions	4
	7.1.7. AC Motors with Brakes	6

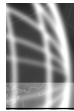

## 7.1. Electric Motors

Power Jacks can supply electric motors for all applications whether AC or DC motors are required. Detailed in this section of the Design Guide are some of the most popular motors used in industrial applications.

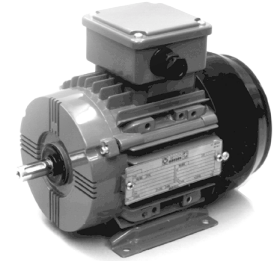

### 7.1.1. AC Motors

#### Standard Specification

- 3 Phase, 50 Hz / 60Hz.
- 220-240/380-415V up to 3kW.
- 380-415/660-720V 4 kW & above.
- B3 Foot, B5 Flange and B14 Face Mounting. (or a combination).
- 4 Pole (1500 rpm).
- 6 Pole (1000rpm).
- IEC Frame Sizes 63 → 200.
- Enclosure IP55, TEFV.
- SI Continuous rating.

#### Features

- High efficiency - low running costs.
- Low noise levels.
- High power factors.
- High torque with smooth acceleration and low current.
- Multi-mount versatility for mounting arrangement and terminal box position.
- Aluminium construction for light weight and corrosion resistance.
- Four position cable entry.

#### Optional

- Brake motors - AC or DC units.
- 2 and 8 Pole 3 phase AC motors.
- Single phase AC motors.
- DC motors - permanent magnet or servo.
- Cast Iron or Steel construction motors.
- High altitude and high temperature options.
- Integral AC inverter.
- Integral encoder and/or Forced ventilation.
- Enclosures IP56 → IP68.
- Tropicalised motors.
- NEMA and Japanese standard units.
- Marine motors.
- Explosion proof motors.

### 7.1.2. AC Motor Performance Data - 1500 rpm (4 Pole)

Power	Full Load Speed (rpm)	Frame Size	FLC I <sub>N</sub> (Amps)			Efficiency η (%)			Power Factor CosØ P <sub>N</sub>			Full Load Torque	Direct on Line				Star Delta Y			Air Vel.	Rotor Inertia	Noise Level	
			380 V	400 V	415 V	1.0	0.75	0.5	1.0	0.75	0.5		M <sub>A</sub> /M <sub>N</sub>	SCR	POT	PUT	STR	SCR	PUT				V m/s
0.12	0.166	1360	63S	0.50	0.47	0.47	59.0	52.0	42.0	0.62	0.53	0.40	0.85	1.9	2.75	2.0	1.65	-	-	-	5	0.0005	39
0.18	0.25	1370	63S	0.67	0.64	0.64	62.0	58.0	51.0	0.66	0.56	0.44	1.25	2.2	3.1	2.2	2.0	-	-	-	5	0.00063	39
0.25	0.33	1400	71S	0.84	0.80	0.8	69.0	68.0	62.0	0.65	0.55	0.44	1.71	1.8	4.0	2.2	1.6	-	-	-	5	0.00084	49
0.37	0.5	1410	71S	1.17	1.11	1.11	71.0	69.0	63.0	0.68	0.57	0.45	2.5	1.8	4.0	2.2	1.6	-	-	-	5	0.00087	49
0.55	0.75	1410	80M	1.66	1.58	1.58	75.0	75.0	70.0	0.67	0.57	0.45	3.7	2.0	4.2	2.4	1.8	-	-	-	7.5	0.0015	49
0.75	1.0	1410	80M	1.97	1.88	1.88	78.0	79.0	77.0	0.74	0.65	0.50	5.1	1.8	4.4	2.2	1.6	-	-	-	7.5	0.0019	49
1.1	1.5	1410	90S	2.76	2.63	2.63	79.5	80.0	78.0	0.76	0.66	0.52	7.5	2.2	5.1	2.5	2.0	-	-	-	9	0.0028	52
1.5	2.0	1420	90L	3.7	3.5	3.5	81.0	82.0	80.0	0.77	0.68	0.55	10.1	2.5	5.6	2.8	2.2	-	-	-	9	0.0035	52
2.2	3.0	1415	100L	5.0	4.8	4.8	83.5	83.5	83.0	0.80	0.74	0.61	14.8	2.2	5.5	2.5	1.9	-	-	-	10	0.008	55
3	4.0	1415	100L	6.7	6.4	6.4	84.5	85.5	85.0	0.80	0.74	0.61	20.2	2.3	5.8	2.5	2.1	-	-	-	10	0.009	55
4	5.5	1440	112M	8.7	8.3	8.3	86.5	87.0	86.0	0.80	0.74	0.60	26.5	2.5	7.0	2.9	2.1	0.75	2.2	0.65	11	0.015	56
5.5	7.5	1450	132S	11.6	11.0	11.0	88.0	88.5	88.0	0.82	0.76	0.64	36.2	2.4	7.5	2.9	2.1	0.70	2.2	0.60	12	0.027	59
7.5	10	1450	132M	15.4	14.7	14.7	89.0	89.5	89.0	0.83	0.77	0.65	49.4	2.5	7.5	2.9	2.1	0.70	2.2	0.60	12	0.029	59
11	15	1470	160M	22.0	20.9	20.9	91.5	91.5	90.5	0.83	0.78	0.67	71.5	2.5	7.7	2.9	2.0	0.65	2.3	0.50	12.5	0.068	63
15	20	1470	160L	29.4	28.0	28.0	92.0	92.5	91.5	0.84	0.79	0.68	97.5	2.5	7.7	2.9	2.0	0.65	2.3	0.50	12.5	0.084	63
18.5	25	1470	180M	37.0	35.0	35.0	92.5	92.5	91.5	0.82	0.76	0.64	120	2.8	8.4	3.2	2.2	0.80	2.6	0.65	13.5	0.17	66
22	30	1470	180L	43.0	41.0	41.0	93.0	93.0	92.0	0.84	0.80	0.69	143	2.5	7.5	2.9	2.0	0.75	2.2	0.60	13.5	0.19	66
30	40	1465	200L	58.0	55.0	53.0	92.5	92.5	91.7	0.85	0.82	0.73	196	2.8	6.7	2.6	2.25	0.75	2.1	0.50	14.5	0.40	65

STR = Starting Torque Ratio  
POT = Pull Out Torque Ratio

SCR = Starting Current Ratio  
V = Air Velocity

PUT = Pull Up Torque Ratio  
J = Rotor Inertia WK<sup>2</sup>



### 7.1.3. AC Motor Performance Data - 1000 rpm (6 Pole)

Power Jacks can supply electric motors for all applications whether AC or DC motors are required. Detailed in this section of the Design Guide are some of the most popular motors used in industrial applications.

Power		Full Load Speed (rpm)	Frame Size	FLC I <sub>N</sub> (Amps)			Efficiency η (%)			Power Factor CosØ P <sub>N</sub>			Full Load Torque	Direct on Line				Star Delta Y			Air Vel.	Rotor Inertia	Noise Level
kW	hp			380 V	400 V	415 V	1.0	0.75	0.5	1.0	0.75	0.5		M <sub>N</sub> Nm	STR	SCR	POT	PUT	STR	SCR			
		n min <sup>-1</sup>										M <sub>A</sub> / M <sub>N</sub>	I <sub>A</sub> / I <sub>N</sub>	M <sub>k</sub> / M <sub>N</sub>	M <sub>s</sub> / M <sub>N</sub>	M <sub>A</sub> / M <sub>N</sub>	I <sub>A</sub> / I <sub>N</sub>	M <sub>s</sub> / M <sub>N</sub>	V m/s	J kgm <sup>2</sup>	L <sub>PA</sub> dB(A)		
0.07	0.094	880	63S	0.36	0.34	0.33	47.0	42.0	33.0	0.63	0.56	0.49	0.76	2.0	2.5	2.2	1.8	-	-	-	4	0.00063	40
0.09	0.125	930	71S	0.48	0.46	0.46	55.0	52.0	47.0	0.59	0.50	0.40	0.93	1.7	2.5	1.9	1.5	-	-	-	4	0.00081	55
0.12	0.166	900	71S	0.58	0.55	0.55	53.0	50.0	43.0	0.59	0.50	0.40	1.24	1.4	3.5	1.7	1.3	-	-	-	4	0.00081	55
0.18	0.25	910	71S	0.79	0.75	0.75	61.0	59.0	53.0	0.57	0.50	0.39	1.87	1.7	3.0	1.9	1.5	-	-	-	4	0.00097	55
0.25	0.33	920	71S	1.11	1.06	1.06	61.0	59.0	53.0	0.56	0.49	0.38	2.6	1.7	3.0	1.9	1.5	-	-	-	4	0.00124	55
0.37	0.5	920	80M	1.33	1.27	1.27	69.0	68.0	64.0	0.61	0.51	0.40	3.8	2.0	3.7	2.2	1.8	-	-	-	6.5	0.0015	55
0.55	0.75	920	80M	1.86	1.77	1.77	71.0	71.0	65.0	0.63	0.54	0.41	5.7	2.0	3.7	2.3	1.8	-	-	-	6.5	0.0021	55
0.75	1.0	920	90S	2.23	2.12	2.12	74.0	74.0	72.0	0.69	0.59	0.45	7.8	2.2	4.1	2.4	2.0	-	-	-	7.5	0.0028	65
1.1	1.5	940	90L	3.4	3.2	3.2	78.0	77.0	75.0	0.63	0.52	0.41	11.2	2.8	4.5	3.0	2.5	-	-	-	7.5	0.0039	65
1.5	2.0	930	100L	4.5	4.3	4.3	79.0	79.0	77.0	0.64	0.54	0.42	15.4	2.0	4.2	2.3	2.0	-	-	-	8	0.009	58
2.2	3.0	950	112M	5.8	5.5	5.5	82.5	82.5	80.5	0.70	0.60	0.47	22.1	2.8	5.8	2.8	2.3	-	-	-	9	0.014	54
3	4.0	965	132S	7.5	7.1	7.1	86.0	86.0	84.5	0.71	0.64	0.52	29.8	2.2	6.5	2.7	1.7	0.65	2.1	0.55	9.5	0.025	54
4	5.5	960	132M	9.4	9.0	9.0	86.5	86.5	86.0	0.74	0.67	0.55	39.8	2.1	6.2	2.6	1.6	0.60	2.0	0.50	9.5	0.029	54
5.5	7.5	960	132M	13.0	12.5	12.5	87.0	87.0	86.5	0.73	0.66	0.54	54.7	2.0	5.5	2.5	1.6	0.60	2.0	0.50	9.5	0.031	55
7.5	10	975	160M	17.0	16.0	16.0	90.0	90.5	89.0	0.75	0.70	0.60	73.4	1.8	6.5	2.8	1.7	0.55	2.1	0.50	10.5	0.10	59
11	15	975	160L	23.8	22.7	22.7	91.0	91.0	89.5	0.77	0.72	0.60	108	2.0	7.5	2.8	1.9	0.60	2.5	0.50	10.5	0.12	59
15	20	975	180L	32.0	31.0	31.0	91.0	91.0	89.5	0.78	0.73	0.60	147	2.4	6.5	2.8	2.2	0.65	2.2	0.60	11	0.23	59
18.5	25	975	200L	38.0	37.0	35.0	91.0	91.0	90.0	0.80	0.76	0.67	181	2.6	6.0	2.1	2.0	0.65	1.8	0.45	12	0.51	62
22	30	975	200L	45.0	43.0	42.0	91.5	91.5	90.5	0.80	0.76	0.67	215	2.6	6.0	2.1	2.0	0.65	1.8	0.45	12	0.6	62

STR = Starting Torque Ratio  
POT = Pull Out Torque Ratio

SCR = Starting Current Ratio  
V = Air Velocity

PUT = Pull Up Torque Ratio  
J = Rotor Inertia WK<sup>2</sup>

### 7.1.4. AC Motors with Integral Encoder

Standard AC motors are available with hollow shaft incremental encoder suitable for most advanced inverters to give a closed loop control or as a speed or position feedback indicator:

- Flexible hollow shaft design.
- Maximum speed = 6000 rpm.
- Protection class IP64, IP65 on request.
- Overall motor enclosure rating IP55 as standard.
- Operating temperature: -10°C → +70°C.
- Standard output signal: 5 VDC, RS422, quadrature, marker and compliments (A, B, N, A, B, N)
- Current consumption: 40 mA @ 5 VDC.
- Number of pulses per revolution: 0 → 8192
- Other encoder types are available on request including: 10 → 30VDC RS422 and push-pull, absolute encoders.



### 7.1.5. AC Motors with Forced Ventilation

The use of a specially designed, forced cooled motor, with a separately driven constant speed fan can overcome the de-rating problems associated with inverter drives. The fan units operate on a 50 Hz supply as follows:-

Frame size 63 → 80 = Single phase, 220/240 VAC Frame size 90 → 180 = Three phase 230/400 VAC

Frame Size	63	71	80	90	100	112	132	160	180
L1	309	332	384	456	487	487	562	730	787
L2	365	387	434	510	560	561	656	849	900

- Note
1. L1 = Motor with encoder and force vent unit.
  2. L2 = Motor with brake, encoder and force vent unit.
  3. Terminal box dimensions for force vent units are 103 x 103 mm.



### 7.1.6. Motor Dimensions

#### 7.1.6.1. B3 - Foot

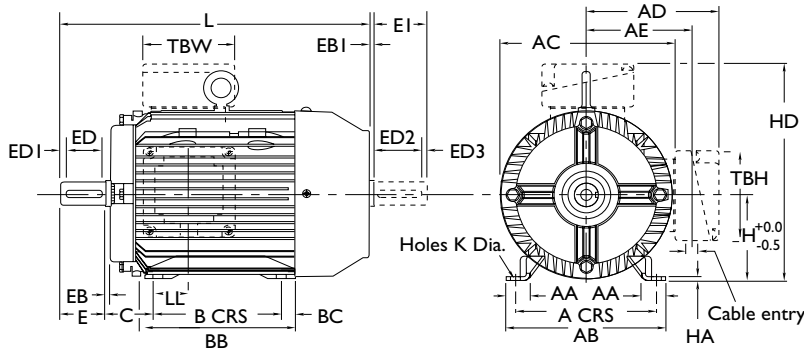

#### 7.1.6.2. B5 or B3/B5 - Flange or Foot/Flange

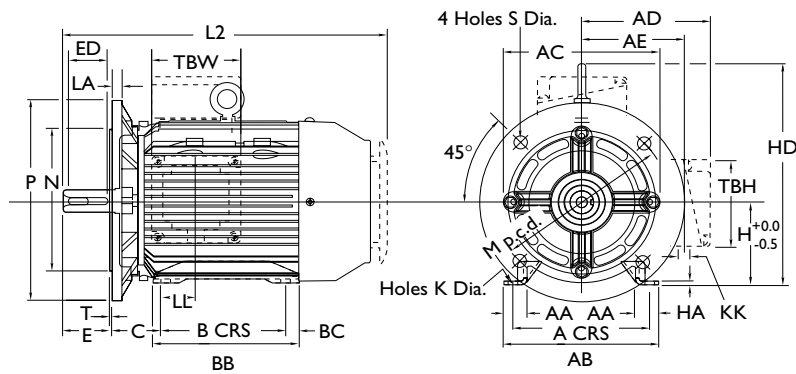

Dim N	British (BS4999) Tol. Limits	European (DIN42948) Tol. Limits
95 & 110	h8 +0.000 - 0.054	j6 +0.013 - 0.009
130 & 180	h8 +0.000 - 0.063	j6 +0.014 - 0.011
230 & 250	h8 +0.000 - 0.072	j6 +0.016 - 0.013
300	h8 +0.000 - 0.081	j6 +0.016 - 0.016

#### 7.1.6.3. B14 or B3/B14 - Face or Foot/Face

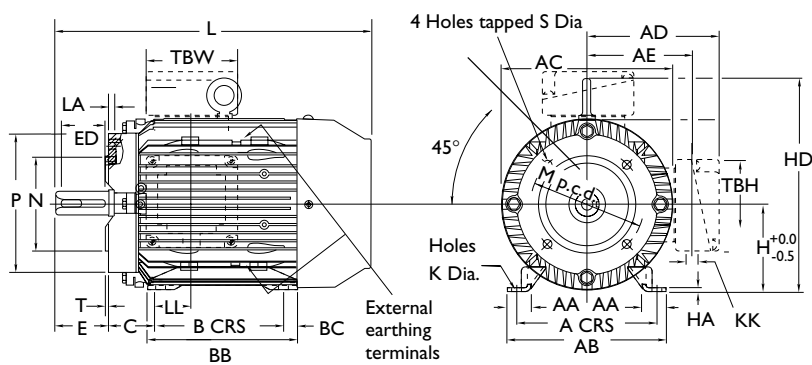

Dim N	British (BS4999) Tol. Limits	European (DIN42948) Tol. Limits
60 & 80	h8 +0.000 - 0.048	j6 +0.012 - 0.009
95 & 110	h8 +0.000 - 0.054	j6 +0.013 - 0.009
130 & 180	h8 +0.000 - 0.063	j6 +0.014 - 0.011

- Notes**
1. All dimensions in millimetres.
  2. Drain holes are standard on frames 132-200 and on request for frames 63-112.
  3. Cable entry can be arranged in any one of four positions at 90 intervals.
  4. No eyebolts on frame sizes 63-100.
  5. Dimensions TBW and TBH are for a metal terminal box. These dimensions will be reduced for plastic boxes (frames 63, 80 and 90).
  6. Dimensions should not be used for installation purposes unless specially endorsed.
  7. Dimensions subject to change without notice.



7.1.6.4. Dimension Tables B3, B5, B3/B5, B14, B3/B14

Typ.	General																	Terminal Box		BS Spec	European Spec	
	A	B	C	H	K	L	L2	AA	AB	BB	BC	HA	AC	AD	HD	AE	EB	LL	TBW/TBH	KK	KK	
63	100	80	40	63	7	207	264	19	119	100	10	2	126	-	169	68	1.5	44	103	103	20	1 x PG 13.5
71	112	90	45	71	7	238	257	19	131	110	10	2	140	-	186	91	6.5	42	86	86	20	1 x PG 13.5
80	125	100	50	80	10	295	315	27	157	127	13.5	4	158	132	212	102	1.5	75	103	103	20	1 x PG 13.5
90SN	140	100	56	90	10	322	342	28	165	152	38.5	4	178	140	220	110	1.5	100	103	103	20	1 x PG 13.5
90LN	140	125	56	90	10	322	342	28	165	152	13.5	4	178	140	220	110	1.5	100	103	103	20	1 x PG 13.5
100L	160	140	63	100	12	368	397	28	184	170	15	4	199	154	234	123	6	32	106	106	20	2 x PG 13.5
112M	190	140	70	112	12	381	410	35	218	170	15	4	215	167	265	133	6	35	127	127	25	2 x PG 16
132S	216	140	89	132	12	451	490	38	242	208	53	5	255	188	306	155	6	25	127	127	25	2 x PG 21
132M	216	178	89	132	12	451	490	38	242	208	15	5	255	188	306	155	6	25	127	127	25	2 x PG 21
160M	254	210	108	160	15	605	644	49	304	304	69	5	314	240	363	196	6	25	140	140	32	2 x PG 29
160L	254	254	108	160	15	605	644	49	304	304	25	5	314	240	363	196	6	25	140	140	32	2 x PG 29
180M	279	241	121	180	15	667	706	50	329	329	63	6	358	260	416	216	7	40	140	140	32	2 x PG 29
180L	279	279	121	180	15	667	706	50	329	329	25	6	358	260	416	216	7	40	140	140	32	2 x PG 29
200L	318	305	133	200	M16	810	855	63	386	355	25	25	410	280	405	235	7	38.5	140	140	32	2 x PG 29 + 1 PG 13.5

Typ.	B5 Mounting							B14 Mounting					
	M	N	P	S	T	LA	M	N	P	S	T	LA	
63	115	95	140	10	3	7	75	60	90	M5	2.5	7	
71	130	110	160	10	3.5	7	85	70	105	M6	2.5	9	
80	165	130	200	12	3.5	12	100	80	120	M6	3	9	
90SN	165	130	200	12	3.5	12	115	95	140	M8	3	9	
90LN	165	130	200	12	3.5	12	115	95	140	M8	3	9	
100L	215	180	250	15	4	12	130	110	160	M8	3.5	12.5	
112M	215	180	250	15	4	12	130	110	164	M8	3.5	13	
132S	265	230	300	15	4	12	165	130	200	M10	3.5	14	
132M	265	230	300	15	4	12	165	130	200	M10	3.5	14	
160M	300	250	350	19	5	13	215	180	250	M12	4	13	
160L	300	250	350	19	5	13	215	180	250	M12	4	13	
180M	300	250	350	19	5	15	-	-	-	-	-	-	
180L	300	250	350	19	5	15	-	-	-	-	-	-	
200L	350	300	400	19	5	19	-	-	-	-	-	-	

Typ.	Shaft DE							Typ.	Shaft Non-Drive end (When provided)							
	D	E	F	G	ED	EDI	DH		DI	EI	FI	GI	ED2	ED3	DHI	EB3
63S	11	23	4	8.5	10	16	M4 x 10	63S	11	23	4	8.5	10	16	M4 x 10	1.5
71	14	30	5	11	20	5	M5 x 12.5	71	14	30	5	11	20	5	M5 x 12.5	1.5
80	19	40	6	15.5	25	32	M6 x 16	80	19	40	6	15.5	25	32	M6 x 16	1.5
90SN	24	50	8	20	32	40	M8 x 19	90SN	24	50	8	20	32	40	M8 x 19	1.5
90LN	24	50	8	20	32	40	M8 x 19	90LN	24	50	8	20	32	40	M8 x 19	1.5
100L	28	60	8	24	50	5	M10 x 22	100L	28	60	8	24	50	5	M10 x 22	3
112M	28	60	8	24	50	5	M10 x 22	112M	28	60	8	24	50	5	M10 x 22	3
132S	38	80	10	33	70	5	M12 x 28	132S	38	80	10	33	70	5	M12 x 28	3
132M	38	80	10	33	70	5	M12 x 28	132M	38	80	10	33	70	5	M12 x 28	3
160M	42	110	12	37	100	5	M16 x 36	160M	42	110	12	37	100	5	M16 x 36	5
160L	42	110	12	37	100	5	M16 x 36	160L	42	110	12	37	100	5	M16 x 36	5
180M	48	110	14	42.5	100	5	M16 x 36	180M	48	110	14	42.5	100	5	M16 x 36	5
180L	48	110	14	42.5	100	5	M16 x 36	180L	48	110	14	42.5	100	5	M16 x 36	5
200L	55	110	16	49	100	5	M20 x 42	200L	55	110	16	49	100	5	M20 x 42	5

Shaft Dim D	British and European	
	Tol.	Limits
11 to 18	j6	+0.008 -0.003
19 to 28	j6	+0.009 -0.004
32 to 48	k6	+0.018 +0.002
55	m6	+0.030 +0.011

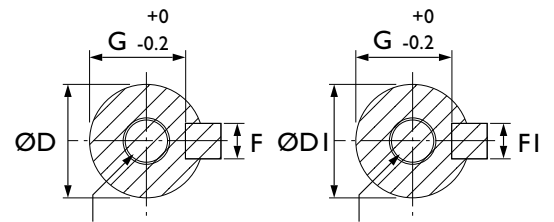

Shaft tapped DH x deep to DIN 332 Form D

Shaft tapped DH1 x deep to DIN 332 Form D

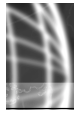

### 7.1.7. AC Motors with Brakes

The brake units are a single disc type mounted on the non-drive end-shield of the motor and can be either DC or AC types. They are spring applied electrically released units, which provide fail to safe operating characteristics such that on interruption, or failure of power supply, the brake will engage and arrest the load.

With DC brakes, the brake coil is fed via a rectifier in the motor terminal box and is automatically switched with the AC motor supply. AC brakes are connected directly to the motor terminals. They can however be separately energised from their own AC supply, in the case of inverter drives and/or where very fast brake operation is required.

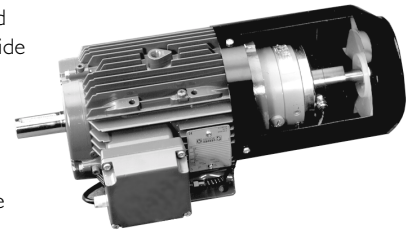

4 Pole (1500 rpm) AC Motor						
Motor		DC Brake		AC Brake		
Power (kW)	Speed (rpm)	Frame Size	Brake Size	Brake Braking Torque (Nm)	Brake Size	Brake Braking Torque (Nm)
0.12	1360	63 S	08	4	07	2
0.18	1370	63 S	08	4	07	2
0.25	1400	71 S	08	4	07	2
0.37	1410	71 S	08	4	09	5
0.55	1410	80 M	10	10	09	5
0.75	1410	80 M	10	10	09	5
1.1	1410	90 S	11	20	10	7.5
1.5	1420	90 L	11	20	11	15
2.2	1415	100 L	13	40	13	35
3	1415	100 L	13	40	13	35
4	1440	112 M	13	40	13	35
5.5	1450	132 S	16	80	13	35
7.5	1450	132 M	16	80	16	75
11	1470	160 M	19	150	19	75
15	1470	160 L	24	240	-	-
18.5	1470	180 M	24	240	-	-
22	1470	180 L	24	240	-	-
30	1465	200 L	-	-	-	-

6 Pole (1000 rpm) AC Motor						
Motor		DC Brake		AC Brake		
Power (kW)	Speed (rpm)	Frame Size	Brake Size	Brake Braking Torque (Nm)	Brake Size	Brake Braking Torque (Nm)
0.07	880	63 S	08	4	07	2
0.09	930	71 S	08	4	07	2
0.12	900	71 S	08	4	07	2
0.18	910	71 S	08	4	07	2
0.25	920	71 S	08	4	09	5
0.37	920	80 M	10	10	09	5
0.55	920	80 M	10	10	10	7.5
0.75	920	90 S	11	20	10	7.5
1.1	940	90 L	13	40	11	15
1.5	930	100 L	13	40	13	35
2.2	950	112 M	13	40	13	35
3	965	132 S	16	60	13	35
4	960	132 M	16	60	16	75
5.5	960	132 M	19	150	16	75
7.5	975	160 M	19	240	16	75
11	975	160 L	24	240	-	-
15	975	180 L	24	240	-	-
18.5	975	200 L	-	-	-	-
22	975	200 L	-	-	-	-

- Note**
1. Enclosure rating is IP55 as standard, IP56 or 65 available on request.
  2. Manual hand release handle can be fitted on request.
  3. Larger brake motors and brakes for other motor models are available on request.

The following brake motor lengths replace those listed in the motor dimension section.

Frame Size	63	71	80	90S/L	100L	112M	132S/M	160M/L	180M/L
Dimension "L"	306	293	367	425	454	468	543	737	809