



POWER JACKS

manufacturers of precision screw jacks, actuators and gearboxes

Group

METRIC BALL SCREW JACKS

SINGLE FACE MOUNTING

(MECHANICAL LINEAR ACTUATORS)

SPARES LIST &

MAINTENANCE

INSTRUCTIONS

MANUAL : MM-MBS-E-02

SUPPLIED BY: POWER JACKS LIMITED



Metric Series – Ball Screw Jacks

CONTENTS

1	UNIT DETAILS	2
2	PERFORMANCE RATINGS	3
2.1	PERFORMANCE OF STANDARD METRIC BALL SCREW ACTUATORS	3
2.2	METRIC SCREW ACTUATOR EFFICIENCIES.....	3
3	GENERAL INSTRUCTIONS	4
3.1	MAINTENANCE AND INSTALLATION RECOMMENDATIONS.	4
4	RECOMMENDED LUBRICANTS	4
5	GENERAL ASSEMBLY & PARTS LIST	5
5.1	GENERAL ARRANGEMENT – PART A	5
5.2	GENERAL ARRANGEMENT – PART B	6
5.3	PARTS LIST.....	6
6	DISASSEMBLY / ASSEMBLY INSTRUCTIONS (D.A.I.)	7
6.1	TRANSLATING SCREW D.A.I.	7
6.2	ROTATING SCREW D.A.I.	8
7	WARRANTY INFORMATION	9
7.1	LIMITATION OF RESPONSIBILITY	9
7.2	WARRANTY	9

1 Unit Details

Serial Number	
Model Number	
Power Jacks Sales Order Number	

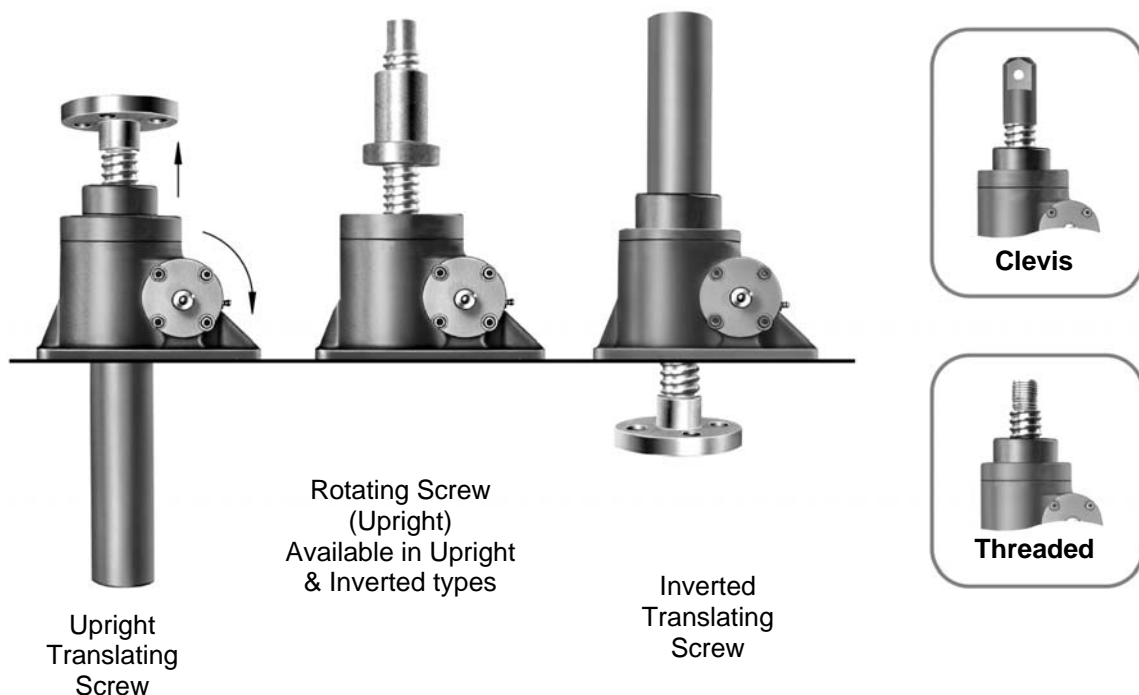



Metric Series – Ball Screw Jacks

2 Performance Ratings

2.1 Performance of Standard Metric Ball Screw Jacks

Actuator Model	28501	2802		2805		2810		2820		2830	2860	Available on Request
	10	25		50		100		200		300	500	
Lifting Screw	Diameter	20mm	25mm		40mm		50mm		63mm		80mm	
	Pitch	5mm	5mm	10mm	10mm	20mm	10mm	20mm	10mm	20mm	10mm	
Worm Gear Ratio	Standard	5	6:1		6:1		8:1		8:1		10 2/3:1	
	Optional	20	24:1		24:1		24:1		24:1		32:1	
Turn of worm for Raise of Lifting Screw	standard	10 for 10mm	12 for 10mm	6 for 10mm	6 for 10mm	3 for 10mm	8 for 10mm	4 for 10mm	8 for 10mm	4 for 10mm	5.33 for 10mm	
	Optional	40 for 10mm	48 for 10mm	24 for 10mm	24 for 10mm	12 for 10mm	24 for 10mm	12 for 10mm	24 for 10mm	12 for 10mm	16 for 10mm	
Maximum Input Power Per actuator (kW)	Standard	0.375	1.5		3		3.75		3.75		6	
	Optional	0.18	0.375		0.55		1.125		1.125		1.9	
Start-up Torque at full load (Nm) †	Standard	2.7	5.9	11.1	23.4	44.6	36.4	68.5	75.2	139.4	182	
	Optional	1.2	2.6	4.9	10.7	20.4	19.1	35.8	39.4	72.9	107.3	
Weight with base raise of 150mm (kg)	2.8	8.17		15.88		24.72		45		86		
Wright for each additional 25mm raise (kg)	0.08	0.21		0.32		0.57		0.86		1.58		

† For loads of 25% to 100% of actuator capacity, torque requirements are approximately proportioned to the load

2.2 Metric Ball Screw Jack Efficiencies

2.2.1 Standard Gear Ratio

Actuator Model	28501	2802		2805		2810		2820		2830	2860	Available on Request
Gear Ratio	5	6		6		8		8		10 2/3		
Lifting Screw Lead (mm)	5	5	10	10	20	10	20	10	20	20		
Actuator Static Efficiency	0.603	0.565	0.600	0.567	0.595	0.546	0.581	0.529	0.571	0.492		
Actuator Dynamic Efficiency	0.681	0.662	0.692	0.663	0.687	0.645	0.674	0.631	0.665	0.595		

2.2.2 Optional Gear Ratio

Actuator Model	28501	2802		2805		2810		2820		2830	2860	Available on Request
Gear Ratio	20	24		24		24		24		32		
Lifting Screw Lead (mm)	5	5	10	10	20	10	20	10	20	20		
Actuator Static Efficiency	0.341	0.320	0.340	0.310	0.325	0.348	0.370	0.337	0.364	0.278		
Actuator Dynamic Efficiency	0.429	0.419	0.438	0.407	0.422	0.450	0.470	0.440	0.465	0.371		

Note Efficiency values are for standard grease lubricated worm gear box and lifting screw.



Metric Series – Ball Screw Jacks

3 General Instructions

3.1 Maintenance and Installation recommendations.

In order to ensure that the actuators give good service over a period of years the following precautions should be taken.

- 3.1.1 Select an actuator which has a rated capacity greater than the maximum load that may be imposed on it.
- 3.1.2 The structure on which the actuators are mounted have ample strength to carry the maximum load, and should be rigid enough to prevent undue deflection or distortion of the actuator supporting members.
- 3.1.3 It is essential that the actuators be carefully aligned during installation so that the lifting screws are vertically true and the connecting shafts are exactly in line with the worm shafts. After the actuators, shafting, gearboxes, etc., are coupled together it should be possible to turn the main drive by hand. If there are no signs of binding or misalignment, the actuator system is then ready for normal operation.
- 3.1.4 The actuators should have a greater raise than is needed in the actual installation. Should it be necessary to operate the actuators at the extreme limits of travel it should be done cautiously.
- 3.1.5 It is important that the lifting screws should not be closed below the specified closed height dimension of the actuators, otherwise serious damage may result to the worm gear. Lifting screw end stops are to prevent over-travel or loss of screw. These are not load supporting and should be treated as an emergency device only and must not be allowed to come into contact with the worm gears during normal working cycles otherwise serious damage will result to worm gears and bearings.
- 3.1.6 The maximum worm shaft speed for these actuators should not exceed 500 R.P.M. for heavy loads. Refer to Power Jacks Limited for higher worm shaft speeds for lighter loads.
- 3.1.7 The lifting screws should not be permitted to accumulate dust and grit on the threads. If possible, lifting screws should be returned to the closed height position when not in use.
- 3.1.8 The ball screw should be checked periodically for excessive backlash and spalling of raceways. Note all Power Jacks Metric ball screw actuators have an integral safety device as standard in the ball nut.

Ball Nut Safety Device provides two important safety roles:-

- 3.1.8.1 In the unlikely event of excessive wear in the ball screw drive, the safety ring will contact the screw shaft, and act as an “ACME” Thread. This will provide early warning of any possible ball screw failure, and is capable of providing drive in the event of any such failure.
- 3.1.8.2 It allows the ball nut on the actuator to sustain a load in the event of catastrophic ball failure. The safety of industrial and human cargo is therefore improved. Ball screw systems without this device would collapse under load or drop the carried load.
- 3.1.9 The actuators are shipped packed with grease (unless otherwise called for) which should be sufficient for one month of normal operation. For normal operation they should be lubricated about once a month using one of the Extreme Pressure Greases or their equivalent. See “Recommended Lubricants” Table 1.
- 3.1.10 For severe service conditions the actuator should be lubricated with a molybdenum disulphide type of grease about once a week. We recommend any of the greases indicated in “Recommended Lubricants” Table 2.

4 Recommended Lubricants

Manufacturer	Lubricant
Castrol	Spheerol EPL2
Esso	Beacon EP2
Gulf	Gulfcrown EP2
Mobiloil	Mobilux EP2
Power Petroleum	BP Energrease LC2
Regent	Texaco EP2
Shell	Alvania WR2

Manufacturer	Lubricant
Castrol	Spheerol EPL2
Esso	Beacon Q2
Mobiloil	Mobilgrease Special
Power Petroleum	BP Energrease L2 1M
Regent	Molytex 2
Shell	Shell Greases 5826 (Overseas) Shell Alvania 2 + MoS ₂



Metric Series – Ball Screw Jacks

5 General Assembly & Parts List

5.1 General Arrangement – Part A

Translating Screw

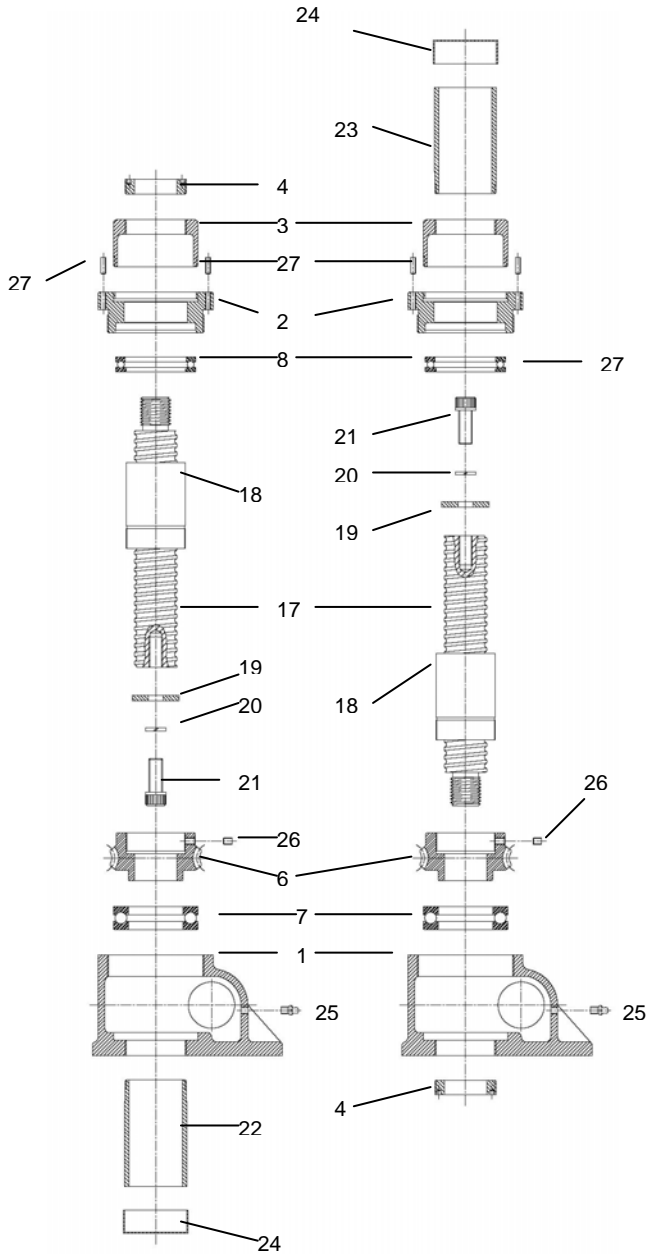

Upright

Inverted

Rotating Screw

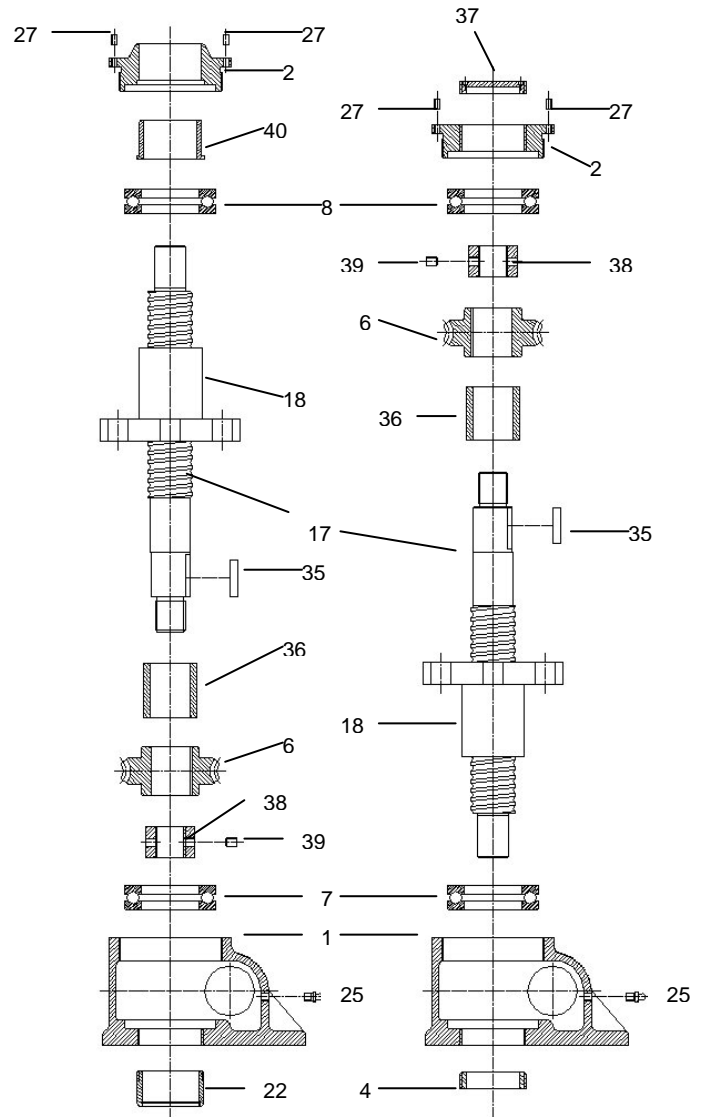

Upright

Inverted



Metric Series – Ball Screw Jacks

5.2 General Arrangement – Part B

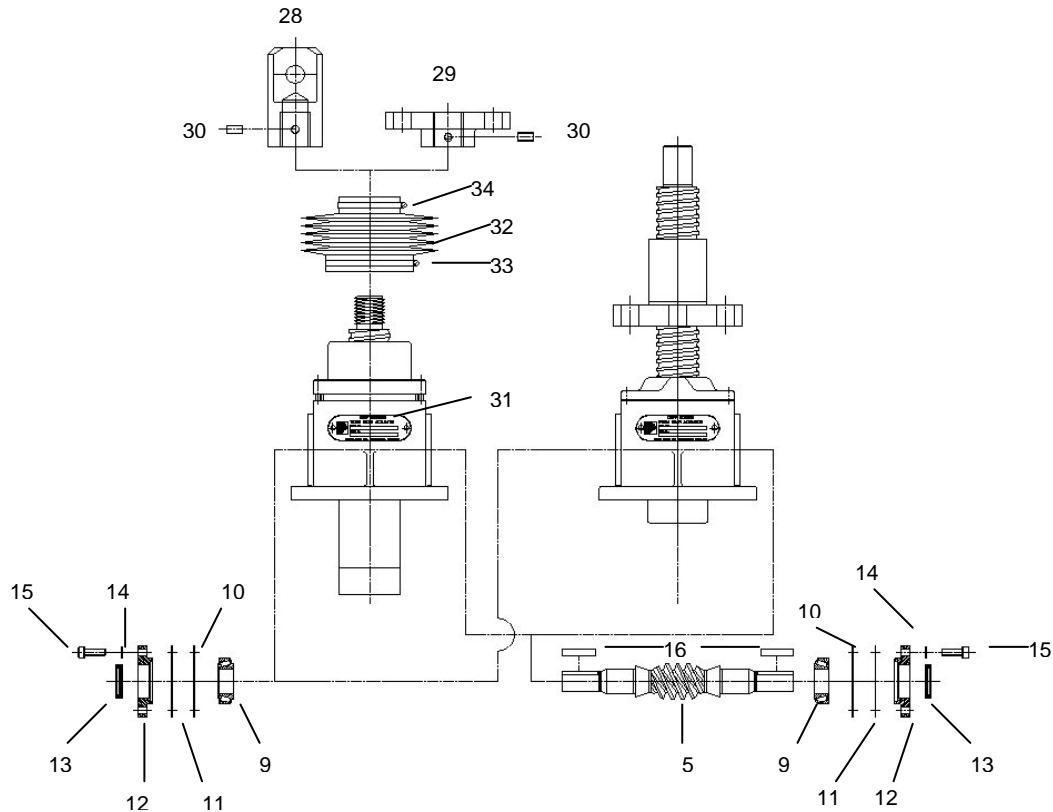

5.3 Parts List

Item No	Description	Item No	Description
1	Shell	19	Retaining Disc
2	Shell Cap	20	Lock Washer (Ball Screw)
3	Top Cap	21	Cap Screw (Ball Screw)
4	Guide Bushing	22	Bottom Pipe
5	Worm Shaft (6:1)	23	Top Pipe
	Worm Shaft (8:1)	24	End Cover
	Worm Shaft (24:1)	25	Grease Nipple
6	Worm Gear (6:1)	26	Set Screw (Worm Gear) – 2 off at 90 degrees
	Worm Gear (8:1)	27	Set Screw (Shell Cap)
	Worm Gear (24:1)	28	Clevis End
7	Load Bearing – Lower	29	Top Plate
8	Load Bearing – Upper	30	Set Screw (End Fixture) – 2 off at 90 degrees
9	Worm Shaft Bearing	31	Name Plate (includes fixing screws)
10	Shim (0.1mm thick)	32	Bellows Boot
11	Shim (0.25mm thick)	33	Jubilee Clip (Bellows Boot – Big)
12	Flange	34	Jubilee Clip (Bellows Boot – Small)
13	Oil Seal	35	Drive Key (Lifting Screw)
14	Lock Washer	36	Sleeve (Lifting Screw)
15	Cap Screw	37	Top Cap
16	Key (Worm Shaft)	38	Lock Nut
		39	Grub Screw (Lock Nut)
17	Ball Screw – Single Start	40	Guide Bushing (Plain)
	Ball Screw – Double Start		
18	Ball Nut – Single Start		
	Ball Nut – Double Start		



Metric Series – Ball Screw Jacks

6 Disassembly / Assembly Instructions (D.A.I.)

6.1 Translating Screw D.A.I

6.1.1 Main Gearbox Unit

IMPORTANT

Disassembly should be accomplished on a clean cloth. This is particularly important when disassembling the ball nut assembly.

1. Remove any end fixture from the end of the ball screw (17).
2. Remove the ball screw guide bushing (4).
3. Remove the bottom pipe (22) or top pipe (23).
4. Ensure that shell cap set screws (27) are slackened back clear of drill dimples in shell (1) before unscrewing shell cap (2). Note: it may be necessary to tap shell cap loose.
5. Remove the top load bearing from the shell cap.

CAUTION! It is very important that the ball screw (17) not be allowed to run out of the ball nut (18). At this point it is advisable to wrap tape around the last few ball screw threads to prevent this from happening.

6. On some models it will be necessary to remove the worm shaft (5) before the worm gear assembly can be pulled clear of the shell.
7. Take care not to lose the flange shims (10 & 11) if removing the worm shaft assembly.
8. To remove the ballscrew assembly (17 & 18) from the worm gear (16), first remove the retaining disc & bolt (19,20 & 21) from the end of the ball screw (17).
9. Remove set screws (26) and unscrew the ball nut (18) from the gear (6). Note on re-assembly it may be necessary to re-drill dimples for the set screws (26).
10. Check all parts for damage or excessive wear and replace where necessary. Note some ball screw and nut assemblies (17 & 18) can be refurbished dependant on the extent of wear/damage.
11. After re-assembly of the worm shaft assembly, strike each end of worm sharply with a wooden or fibre mallet to seat bearings properly. If new parts have been fitted it may be necessary to increase or decrease the number of shims to obtain the correct endplay – the worm shaft should turn freely with the minimum of endplay.
12. Press oil seals (13) into worm flanges (12) with the sealing members pointing inwards.
13. When re-assembling the worm gear and load bearings ensure that the bearings are fitted so that the plate with the smallest bore size fits over the worm gear spigot.
14. The shell cap should be fitted after the worm shaft assembly has been securely clamped and with the worm gear assembly in position. Tighten the shell cap until a slight drag is felt on rotating the worm shaft by hand.
15. Tighten shell cap set screws (27). It may be necessary to drill new dimples in the shell if new parts have been fitted or if re-adjustment for wear is necessary.
16. Attach the bottom pipe (22) or top pipe (23).
17. Attach the ball screw guide bushing (4).
18. Re-assemble any end fixture to the ball screw (17)

6.1.2 Instructions for fitting detachable ends on lifting screws

It is important that the detachable ends are securely fixed to the lifting screws and the following procedure should be adhered to.

1. Thread the detachable end on to the lifting screw and tighten up as hard as possible without damaging the components.
2. Select a twist drill which is a free fit in the tapped holes of the detachable end. Using these holes as a drill guide, drill dimple only into the lifting screw. Clean out swarf and remove detachable end. Select another drill which matches the set screw diameter and, using the drill dimples as a guide, drill into the lifting screw a full diameter depth of 1mm below the root diameter of the threads. Refit detachable end.



Metric Series – Ball Screw Jacks

- Fit the knurled point set screws (supplied with detachable ends) firmly in place ensuring that point of set screws make contact with bottom of drill dimples. Secure the set screws with Loctite.
- If actuators with keyed lifting screws are involved, and it is required to line up the clevis flats or top plate holes, etc., in a fixed relationship to the worm shaft centreline, it will be necessary to face the underside of the detachable end to obtain the required relationship. This operation should be done carefully as only a few hundredths of a mm (thousands of an inch) removed from the attachment is equivalent to a fair amount of rotational movement. After the correct relationship has been obtained with the attachment firmly tightened up, proceed as described in paragraphs 2 & 3.

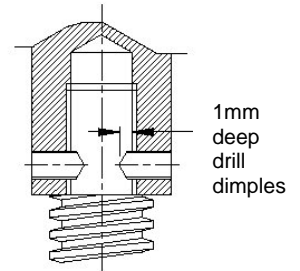

6.2 Rotating Screw D.A.I.

IMPORTANT

Disassembly should be accomplished on a clean cloth. This is particularly important when disassembling the ball nut assembly.

- Remove any end fixture from the end of the ball screw (17).
- Remove bottom pipe (22) or top cap (37).

CAUTION! It is very important the ball screw (17) not be allowed to run out of the ball nut (18). At this point it is advisable to wrap tape round the last few ball screw threads to prevent this from happening

- To remove the ballscrew assembly (17 & 18) from the worm gear (16), first remove the lock nut (38) with retaining grub screw (39) from the end of the ball screw (17).
- Remove the ball screw guide bushing (4).
- Ensure that shell cap set screws (27) are slackened back clear of drill dimples in shell (1) before unscrewing shell cap (2). Note: it may be necessary to tap shell cap loose.
- Remove the top load bearing from the shell cap (8).
- On some models it will be necessary to remove the worm shaft (5) before the worm gear assembly can be pulled clear of the shell. Take care not to lose the flange shims (10 & 11) if removing the worm shaft assembly.
- Check all parts for damage or excessive wear and replace where necessary. Note some ball screw and nut assemblies (17 & 18) can be refurbished dependent on the extent of wear/damage.
- After re-assembly of the worm shaft assembly, strike each end of worm sharply with a wooden or fibre mallet to seat bearings properly. If new parts have been fitted it may be necessary to increase or decrease the number of shims to obtain the correct endplay – the worm shaft should turn freely with the minimum of endplay.
- Press oil seals (13) into worm flanges (12) with the sealing members pointing inwards.
- When re-assembling the worm gear and load bearings ensure that the bearings are fitted so that the plate with the smallest bore size fits over the worm gear spigot.
- The shell cap should be fitted after the worm shaft assembly has been securely clamped and with the worm gear assembly in position. Tighten the shell cap until a slight drag is felt on rotating the worm shaft by hand.
- Tighten shell cap set screws (27). It may be necessary to drill new dimples in the shell if new parts have been fitted or if re-adjustment for wear is necessary.
- Attach the ball screw guide bushing (4).
- Re-assemble the ball screw assembly (17 & 18) to the worm gearbox with lock nut (38) & retaining grub screws (39).
- Attach the bottom pipe (22) or top cap (37).
- Re-assemble any end fixture to the ball screw (17).



Metric Series – Ball Screw Jacks

7 Warranty Information

7.1 Limitation of Responsibility

The ratings given in this manual were compiled using standard engineering procedures. The ratings are designed to guide the customer in the selection of a unit. We do not guarantee the ratings in specific applications. Prototype testing of every application is recommended before production. Our engineering facilities are available for consultation at all times. Please ask us for assistance with linear motion and drive application problems. This manual is designed to assist in the selection of a suitable linear motion or power transmission product for economical, long and trouble free service.

Due to Power Jacks policy of continuous improvement designs may be subject to change without notice. Please ask for certified drawings.

7.2 Warranty

Subject to the condition stated herein, Power Jacks will repair or replace, without charge, any parts proven to Power Jacks satisfaction to have been defective in material or workmanship. Claims must be made within one year after date of shipment. Power Jacks will not repair or replace any parts that have become inoperative because of improper maintenance, eccentric loading, overloading, chemical or abrasive action, excessive heat, or other abuse. Equipment which has been altered or modified by anyone without Power Jacks authorisation, is not warranted by Power Jacks. EXCEPT AS STATED HEREIN, POWER JACKS MAKES NO OTHER WARRANTIES, EXPRESS OR IMPLIED INCLUDING WARRANTIES OF MERCHANTABILITY AND FITNESS FOR A PARTICULAR PURPOSE.

WARNING: The equipment shown in this manual is intended for industrial use only and should not be used to lift support, or otherwise transport people unless you have a written statement from Power Jacks Limited which authorises the specific unit as used in your application suitable for moving people.

© Power Jacks Limited 1987, Aberdeenshire, Scotland, United Kingdom.

We reserve the right to alter details and specifications without notice.

Since special circumstances may affect the equipment's operation, users should consult **POWER JACKS LIMITED** at the address shown, or take other skilled engineering advice. It is recommended that the application design load is conspicuously displayed.

© **POWER JACKS LIMITED. May not be copied in whole or in part**



POWER JACKS GROUP LIMITED
SOUTH HARBOUR ROAD, FRASERBURGH,
ABERDEENSHIRE, AB43 9BZ SCOTLAND
TELEPHONE: +44 (0) 1346 513131 FAX: +44 (0) 1346 516827
email: sales@powerjacks.com <http://www.powerjacks.com>