



POWER JACKS

manufacturers of precision screw jacks, actuators and gearboxes

Group

CUBIC MACHINE SCREW JACK

HIGH DUTY, METRIC
"SYM-METRIC" - SERIES

(MECHANICAL LINEAR ACTUATORS)

SPARES LIST &

MAINTENANCE

INSTRUCTIONS

MANUAL : MM-SMS-E-02

SUPPLIED BY: POWER JACKS LIMITED



Sym-metric Series – Screw Jacks

CONTENTS

1	UNIT DETAILS	2
2	PERFORMANCE RATINGS	3
2.1	PERFORMANCE OF STANDARD SYM-METRIC ACTUATORS	3
2.2	SYM-METRIC ACTUATOR EFFICIENCIES.....	3
3	GENERAL INSTRUCTIONS	4
3.1	MAINTENANCE AND INSTALLATION RECOMMENDATIONS.	4
4	RECOMMENDED LUBRICANTS	4
5	GENERAL ASSEMBLY & PARTS LIST	5
5.1	GENERAL ARRANGEMENT – PART A	5
5.2	GENERAL ARRANGEMENT – PART B.....	6
5.3	PARTS LIST.....	6
6	DISASSEMBLY / ASSEMBLY INSTRUCTIONS (D.A.I.)	7
6.1	TRANSLATING SCREW D.A.I.	7
6.2	ROTATING SCREW D.A.I.	8
7	WARRANTY INFORMATION	9
7.1	LIMITATION OF RESPONSIBILITY	9
7.2	WARRANTY	9

1 Unit Details

Serial Number	
Model Number	
Power Jacks Sales Order Number	

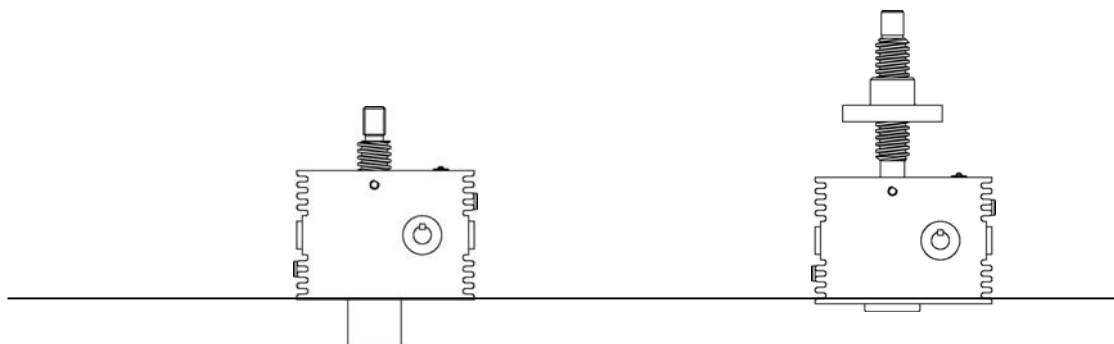

Translating Screw
(Upright and Inverted)

Rotating Screw
(Upright and Inverted)



Sym-metric Series – Screw Jacks

2 Performance Ratings

2.1 Performance of Standard Sym-metric Screw Jacks

Actuator Model		ST025		ST050		ST100		ST200			
Capacity (kN)		25		50		100		200			
Lifting Screw		Diameter		Ø30		Ø40		Ø50		Ø65	
		Pitch		6 mm		9 mm		12 mm		12 mm	
		No of Starts*		1	2	1	2	1	2	1	2
Worm Gear Ratios		Standard		6:1		6:1		8:1		8:1	
		Option 1		8:1		8:1		6:1		6:1	
		Option 2		24:1		24:1		24:1		24:1	
Turn of worm for raise of lifting screw		1 Turn	Standard	1mm	2mm	1.5mm	3mm	1.5mm	3mm	1.5mm	3mm
		4 Turn	Option 1	3mm	6mm	4.5mm	9mm	8mm	16mm	8mm	16mm
		4 Turn	Option 2	1mm	2mm	1.5mm	3mm	2mm	4mm	2mm	4mm
Maximum Input Power per Actuator (kW)		Standard		1.5		3.0		3.75		3.75	
		Option 1		1.5		3.0		3.75		3.75	
		Option 2		0.375		0.550		1.125		1.125	
Start-Up Torque at full Load (Nm) †		Standard		19	26	54	73	111	151	252	330
		Option 1		15	20	44	59	140	190	317	416
		Option 2		8	11	24	33	57	77	129	168
Weight with base raise of 150mm (kg)		13		25		41		70			
Weight for each additional 25mm raise (kg)		0.21		0.32		0.57		0.86			

* Single start lifting screw is standard.

† For loads of 25% to 100% of actuator capacity, torque requirements are approximately proportional to the load.

2.2 Sym-metric Screw Jack Efficiencies

Model	Gear Ratio	Lifting Screw Start	Static Input Speed Zero rpm	Dynamic Input Speed (rpm)			
				50	750	1000	1500
ST025	6:1	1	0.209	0.262	0.299	0.302	0.309
		2	0.314	0.379	0.434	0.438	0.448
	8:1	1	0.194	0.247	0.288	0.293	0.301
		2	0.293	0.358	0.418	0.424	0.436
	24:1	1	0.121	0.164	0.220	0.226	0.239
		2	0.183	0.238	0.320	0.328	0.347
ST050	6:1	1	0.222	0.281	0.324	0.329	0.337
		2	0.325	0.398	0.460	0.466	0.477
	8:1	1	0.206	0.264	0.312	0.318	0.328
		2	0.302	0.374	0.442	0.451	0.465
	24:1	1	0.125	0.171	0.238	0.246	0.263
		2	0.184	0.242	0.337	0.349	0.372
ST100	6:1	1	0.227	0.285	0.324	0.329	0.336
		2	0.336	0.407	0.462	0.469	0.479
	8:1	1	0.214	0.272	0.315	0.320	0.328
		2	0.317	0.389	0.450	0.456	0.468
	24:1	1	0.140	0.188	0.252	0.260	0.274
		2	0.207	0.269	0.359	0.370	0.391
ST200	6:1	1	0.201	0.255	0.289	0.294	0.300
		2	0.307	0.375	0.426	0.432	0.442
	8:1	1	0.190	0.243	0.282	0.286	0.293
		2	0.290	0.358	0.415	0.421	0.431
	24:1	1	0.124	0.168	0.225	0.232	0.245
		2	0.189	0.248	0.331	0.341	0.361

Note Values for standard oil lubricated Sym-metric actuators only, ref: BS 721 part 2. with grease lubricated lifting screw



Sym-metric Series – Screw Jacks

3 General Instructions

3.1 Maintenance and Installation recommendations.

In order to ensure that the actuators give good service over a period of years the following precautions should be taken

- 3.1.1 Select an actuator which has a rated capacity greater than the maximum load that may be imposed on it.
- 3.1.2 The structure on which the actuators are mounted have ample strength to carry the maximum load, and should be rigid enough to prevent undue deflection or distortion of the actuator supporting members.
- 3.1.3 It is essential that the actuators be carefully aligned during installation so that the lifting screws are vertically true and the connecting shafts are exactly in line with the worm shafts. After the actuators, shafting, gearboxes, etc., are coupled together it should be possible to turn the main drive by hand. If there are no signs of binding or misalignment, the actuator system is then ready for normal operation.
- 3.1.4 The actuators should have a greater raise than is needed in the actual installation. Should it be necessary to operate the actuators at the extreme limits of travel it should be done cautiously.
- 3.1.5 It is important that the lifting screws should not be closed below the specified closed height dimension of the actuators, otherwise serious damage may result to the worm gear. Lifting screw end stops are to prevent over-travel or loss of screw. These are not load supporting and should be treated as an emergency device only and must not be allowed to come into contact with the worm gears during normal working cycles otherwise serious damage will result to worm gears and bearings.
- 3.1.6 The maximum worm shaft speed for these actuators should not exceed 500 R.P.M. for heavy loads. Refer to Power Jacks Limited for higher worm shaft speeds for lighter loads. Absolute maximum is 3000rpm provided Power Jacks have advised acceptable.
- 3.1.7 The lifting screws should not be permitted to accumulate dust and grit on the threads. If possible, lifting screws should be returned to the closed height position when not in use.
- 3.1.8 A periodic check of backlash between lifting screw and worm gear is recommended to check wear on internal threads of worm gear. Backlash in excess of 50% thread thickness indicates that a replacement will be necessary to replace the worm gear and nut assembly.
- 3.1.9 The actuators are shipped with the gearbox housing oil filled (unless otherwise required) to the correct level and with the lifting screw packed with grease. This should be sufficient for normal operation. For normal operation the oil level should be checked to read the correct level and the lifting screw lubricated with grease once a month. For lubrication use one of the recommended lubricants (refer Tables 1 & 2)
- 3.1.10 For severe service conditions the actuator should be lubricated with a molybdenum disulphide type of grease daily or weekly depending on the conditions. If duty is heavy, an automatic lubrication system is strongly recommended. If ambient temperature exceeds 90°C (194°F) consult Power Jacks.

4 Recommended Lubricants

TABLE 1 – GEARBOX OIL	
Manufacturer	Lubricant
BP	Energol GR-XP150
Shell	Omala Oil 150
Castrol	Alpha SP150
Mobil	Gear Oil 629

TABLE 2 – LIFTING SCREW GREASE	
Manufacturer	Lubricant
Shell	Alvania WR2
BP	Energol LC2
Castrol	Spheerol L-EP2
Mobil	Mobilux EP2



Sym-metric Series – Screw Jacks

5 General Assembly & Parts List

5.1 General Arrangement – Part A

Translating Screw

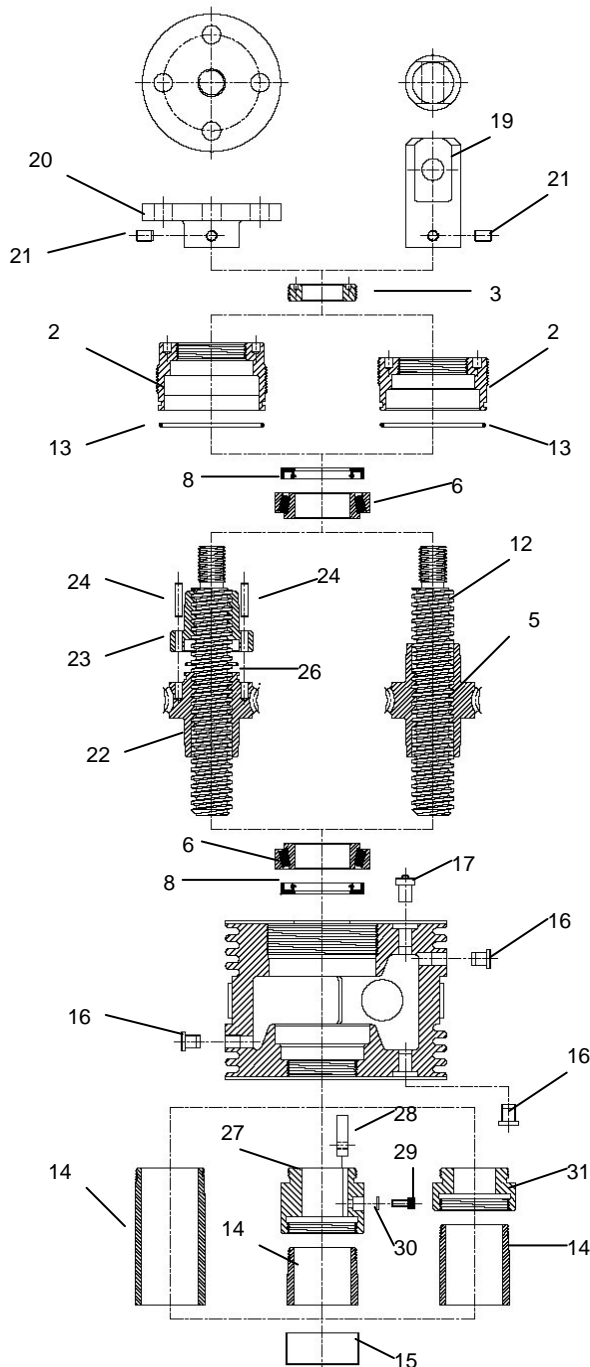

Rotating Screw

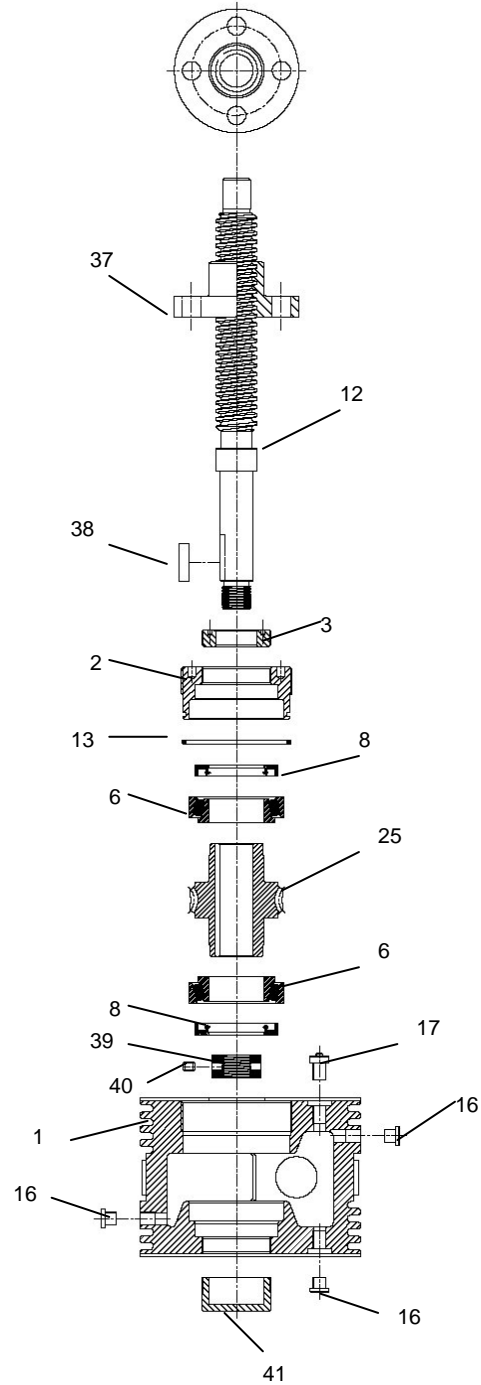



Sym-metric Series – Screw Jacks

5.2 General Arrangement – Part B

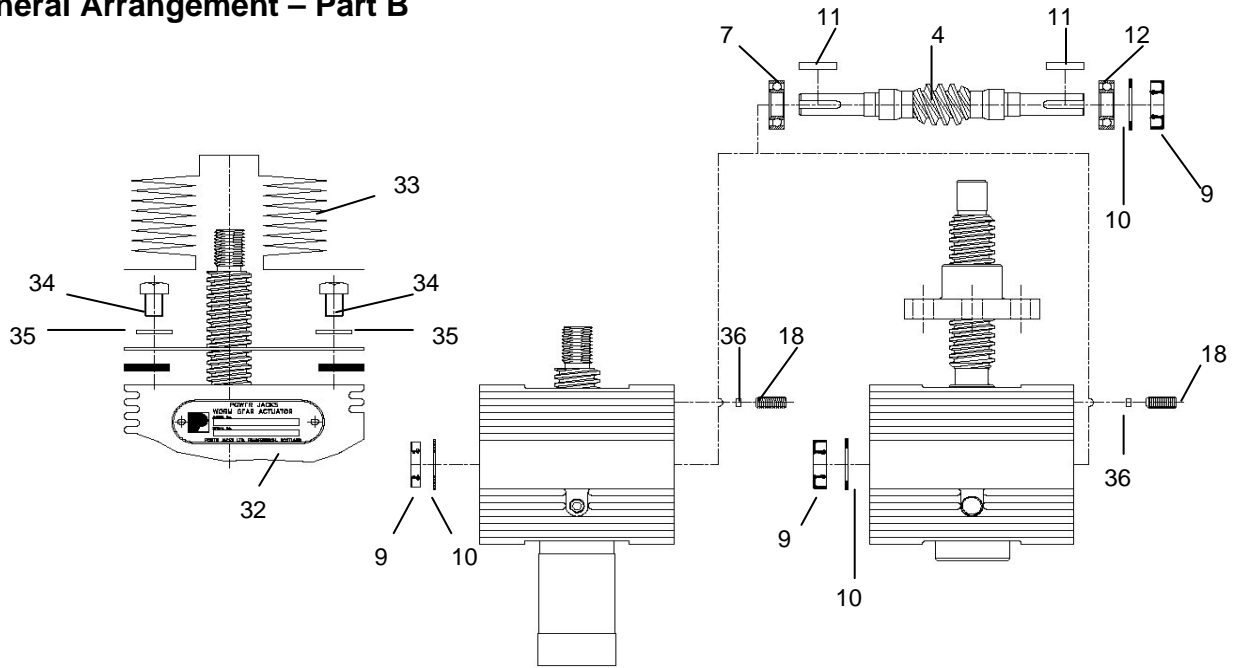

5.3 Parts List

Item No	Description	Qty
1	Shell	1
2	Shell Cap	1
	Shell Cap Anti-backlash	1
	Guide Bushing	1
3	Guide Bushing	1
	Worm Shaft (6:1 Ratio)	1
	Worm Shaft (8:1 Ratio)	1
4	Worm Shaft (24:1 Ratio)	1
	Worm Gear (6:1 Ratio)	1
	Worm Gear (8:1 Ratio)	1
5	Worm Gear (24:1 Ratio)	1
	Worm Gear (6:1 Ratio) Double Start	1
	Worm Gear (8:1 Ratio) Double Start	1
6	Worm Gear (24:1 Ratio)	1
	Load Bearing	2
	Worm Shaft Bearing	2
7	Worm Shaft Bearing	2
8	Seal	2
9	Seal (Worm Shaft)	2
10	Circlip	2
11	Key (Worm Shaft)	2
12	Lifting Screw	1
	Lifting Screw (Keyed)	1
	Lifting Screw (Double Start)	1
	Lifting Screw (Rotating)	1
13	O Ring (Shell Cap)	1
14	Bottom Pipe	1
15	Bottom Pipe Cap	1
16	Plug	3
17	Breather Plug	1
18	Set Screw (M8 x 20mm)	1
19	Clevis End	1
20	Top Plate	1
21	Set Screw (M8 x 12mm)	4
22	Worm Gear (6:1 Ratio – Anti-backlash)	1
	Worm Gear (8:1 Ratio – Anti-backlash)	1
	Worm Gear (24:1 Ratio – Anti-backlash)	1

Item No	Description	Qty
22	Worm Gear (6:1 Ratio-Anti-backlash) Double Start	1
	Worm Gear (8:1 Ratio-Anti-backlash) Double Start	1
	Worm Gear (24:1 Ratio-Anti-backlash) Double Start	1
23	Anti-backlash Nut	1
	Anti-backlash Nut (Double Start)	1
24	Dowels	4
25	Worm Gear (6:1 Ratio - Rotating)	1
	Worm Gear (8:1 Ratio – Rotating)	1
	Worm Gear (24:1 Ratio – Rotating)	1
	Worm Gear (6:1 Ratio- Rotating) Double Start	1
	Worm Gear (8:1 Ratio- Rotating) Double Start	1
	Worm Gear (24:1 Ratio- Rotating) Double Start	1
26	'O' Ring Anti-backlash Nut)	1
27	Key Adaptor	1
	Key Adaptor (Anti-backlash) *	1
28	Key (Lifting Screw)	1
29	Cap Screw	1
30	Lock Washer	1
31	Secondary Guide Bushing	1
32	Name Plate (includes fixing screws)	1
	Bellows Boot Kit	1
	includes Bellows Boot	1
	End Plate	1
33	End Plate Gasket	2
	Hex Headbolt	4
34	Hex Headbolt	4
35	Washer	4
	Locking Plug	1
36	Locking Plug	1
	Lifting Nut – Single Start	1
37	Lifting Nut – Double Start	1
	Drive Key (Lifting Screw)	1
38	Drive Key (Lifting Screw)	1
39	Lock Nut (Lifting Screw)	1
40	Grubscrew (Lifting Screw Locknut)	1
41	Bottom Cap	1

* For anti-backlash keyed inverted screw there is no internal thread on key adaptor.



Sym-metric Series – Screw Jacks

6 Disassembly / Assembly Instructions (D.A.I.)

6.1 Translating Screw D.A.I

6.1.1 Main Unit

- 6.1.1.1 Ensure that shell cap grub screw and plug (18) are slacked back clear of the thread grip (36) in shell (1) before unscrewing the shell cap (It may be necessary to tap shell cap loose).
- 6.1.1.2 On some models it will be necessary to remove the worm shaft (4) before the worm gear assembly can be pulled clear of the shell.
- 6.1.1.3 Check all parts for damage or excessive wear and replace where necessary paying special attention to "O" rings (13) & oil seals (8 & 9).
- 6.1.1.4 After re-assembly of the worm shaft assembly, strike each end of worm sharply with a wooden or fibre mallet to seat bearings properly. (Bearings must be assembled with the shield facing outwards).
- 6.1.1.5 Press oil seals (9) into worm recesses in shell housing (1) with the sealing members pointing inwards.
- 6.1.1.6 When re-assembling the worm gear and load bearings ensure that the bearings are fitted so that the plate with the smallest bore size fits over the worm gear spigot.
- 6.1.1.7 The shell cap should be fitted after the worm shaft assembly has been securely clamped and with the worm gear assembly in position. Tighten the shell cap until a slight drag is felt on rotating the worm shaft by hand.
- 6.1.1.8 For anti-backlash actuators the shell cap must be screwed up with the lifting screw inserted and only as tight as to allow the required backlash and lifting screw and worm gear. For normal screw jack operation the recommended backlash is 0.05mm (0.002").
- 6.1.1.9 Tighten shell cap grub screw (18). It may be necessary to fit a new thread grip if it has become worn due to numerous adjustments.
- 6.1.1.10 For keyed actuators it is recommended that the lifting screw be threaded into the worm gear as far as required before fitting the key (28).
- 6.1.1.11 It is important that the detachable ends are securely fixed to the lifting screws and the following procedure should be adhered to.

6.1.2 Instructions for fitting detachable ends on lifting screws.

- 6.1.2.1 Thread the detachable end on to the lifting screw and tighten up as hard as possible without damaging the components.
- 6.1.2.2 Select a twist drill, which is a free fit in the tapped holes of the detachable end. Using these holes as a drill guide, drill dimple only into the lifting screw. Clean out swarf and remove detachable end. Select another drill which matches the set screw diameter and, using the drill dimples as a guide, drill into the lifting screw a full diameter depth of 1mm below the root diameter of the threads. Refit detachable end.
- 6.1.2.3 Fit the knurled point set screws (supplied with detachable ends) firmly in place ensuring that point of set screws make contact with bottom of drill dimples. Secure the set screws with Loctite.

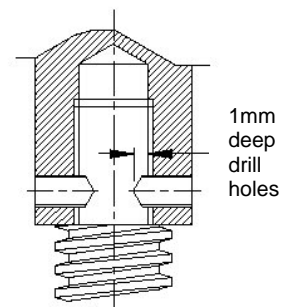

- 6.1.2.4 If actuators with keyed lifting screws are involved, and it is required to line up the clevis flats or top plate holes, etc. in a fixed relationship to the worm shaft centreline, it will be necessary to face the underside of the detachable end to obtain the required relationship. This operation should be done carefully as only a few hundredths of a mm (thousands of an inch) removed from the attachment is equivalent to a fair amount of rotational movement.



Sym-metric Series – Screw Jacks

6.2 Rotating Screw D.A.I.

6.2.1 Main Unit

- 6.2.1.1 Ensure that shell cap grub screw and plug (18) are slackened back clear of the thread grip (36) in shell (1) before unscrewing the shell cap (It may be necessary to tap shell cap loose).
- 6.2.1.2 On some models it will be necessary to remove the worm shaft (4) before the worm gear assembly can be pulled clear of the shell.
- 6.2.1.3 Check all parts for damage or excessive wear and replace where necessary paying special attention to “O” rings (13) & oil seals (8 & 9).
- 6.2.1.4 After re-assembly of the worm shaft assembly, strike each end of worm sharply with a wooden or fibre mallet to seat bearings properly. (Bearings must be assembled with the shield facing outwards).
- 6.2.1.5 Press oil seals (9) into worm recesses in shell housing (1) with the sealing members pointing inwards.
- 6.2.1.6 When re-assembling the worm gear and load bearings ensure that the bearings are fitted so that the plate with the smallest bore size fits over the worm gear spigot.
- 6.2.1.7 The shell cap should be fitted after the worm shaft assembly has been securely clamped and with the worm gear assembly in position. Tighten the shell cap until a slight drag is felt on rotating the worm shaft by hand.
- 6.2.1.8 Tighten shell cap grub screw (18). It may be necessary to fit a new thread grip if it has become worn due to numerous adjustments.



Sym-metric Series – Screw Jacks

7 Warranty Information

7.1 Limitation of Responsibility

The ratings given in this manual were compiled using standard engineering procedures. The ratings are designed to guide the customer in the selection and use of a unit. We do not guarantee the ratings in specific applications. Prototype testing of every application is recommended before production. Our engineering facilities are available for consultation at all times. Please ask us for assistance with linear motion and drive application problems. This manual is designed to assist in the selection of a suitable linear motion or power transmission product for economical, long and trouble free service.

Due to Power Jacks policy of continuous improvement designs may be subject to change without notice. Please ask for certified drawings.

7.2 Warranty

Subject to the condition stated herein, Power Jacks will repair or replace, without charge, any parts proven to Power Jacks satisfaction to have been defective in material or workmanship. Claims must be made within one year after date of shipment. Power Jacks will not repair or replace any parts that have become inoperative because of improper maintenance, eccentric loading, overloading, chemical or abrasive action, excessive wear, or other abuse. Equipment which has been altered or modified by anyone without Power Jacks authorisation, is not warranted by Power Jacks, EXCEPT AS STATED HEREIN, POWER JACKS MAKES NO OTHER WARRANTIES, EXPRESS OR IMPLIED INCLUDING WARRANTIES OF MERCHANTABILITY AND FITNESS FOR A PARTICULAR PURPOSE.

WARNING: The equipment shown in this manual is intended for industrial use only and should not be used to lift support, or otherwise transport people unless you have a written statement from Power Jacks Limited which authorises the specific unit as used in your application suitable for moving people.

© Power Jacks Limited 1987, Aberdeenshire, Scotland, United Kingdom.

We reserve the right to alter details and specifications without notice.

Since special circumstances may affect the equipment's operation, users should consult **POWER JACKS LIMITED** at the address shown, or take other skilled engineering advice. It is recommended that the application design load is conspicuously displayed.

© **POWER JACKS LIMITED. May not be copied in whole or in part**



POWER JACKS GROUP LIMITED
SOUTH HARBOUR ROAD, FRASERBURGH,
ABERDEENSHIRE, AB43 9BZ SCOTLAND
TELEPHONE: +44 (0) 1346 513131 FAX: +44 (0) 1346 516827
email: sales@powerjacks.com <http://www.powerjacks.com>