



OPERATING INSTRUCTIONS

Rack jack
 Typ(e) 11.1,5 11.3 11.5 11.10
 1188.1,5 1188.3 1188.5 1188.10
 Manufactured by Haacon Hebetchnik GmbH



Contents

- | | |
|------------------------|----------------|
| 1. Safety Instructions | 5. Operation |
| 2. Technical Data | 6. Maintenance |
| 3. General | 7. Spare parts |
| 4. Construction | |

1. SAFETY INSTRUCTIONS

Where to use this winch

This rack jack may only be used in accordance with the following operating instructions.

- To be used only if in perfect technical condition.
- To be used by trained personnel only.

Safe working practices

Read these operating instructions carefully before using the rack jack.

Work safely and be aware of dangers at all times.

Ensure ground surface is safe.

Whilst lifting and lowering, the load and load support should be continuously watched.

When lifting with the claw, keep the load as close as possible to the body of the jack.

Inform your supervisor immediately of any damage or faults to the rack jack. Do not operate the rack jack again until the damage or fault has been repaired.

Do not

- Exceed the maximum load (see tech. data and type-/capacity number plate).
- Transport people.
- Work below or on the lifted load.

Winch Application

- Not to be used continuously.

Supervision

- Ensure that these operating instructions are always at hand.
- Do not allow this winch to be operated by untrained staff.
- Check regularly that the winch is operated safely and according to these instructions.

Maintenance and Repair

Installation, maintenance and repair may only be carried out by trained personnel.

Use only original manufacturer's replacement parts.

No changes or modifications may be carried out on parts relevant to safety. Additional equipment must not infringe on safety.

Additional instructions to be adhered to

- Safety and accident prevention regulations.
- National regulations, safety standards and guidelines.

2. TECHNICAL DATA

Type		11.1,5	11.3	11.5	11.10
Order no.	SIKU	200 001	200 002	200 003	200 004
	RAKU	200 007	200 008	200 009	200 010
Permitted load	t	1,5	3	5	10
Overall high	mm	725	725	725	800
Lift	mm	350	350	300	300
Weight	kg	12,5	20	27	42
Order no.Short version	SIKU	200 013	200 014	200 015	200 016
	RAKU	200 019	200 020	200 021	200 022
Permitted load	t	1,5	3	5	10
Overall high	mm	600	600	600	650
Lift	mm	300	300	300	300
Weight	kg	11	18,5	23,5	41
Typ		1188.1,5	1188.3	1188.5	1188.10
Order no.	SIKU	200 025	200 026	200 027	200 028
	RAKU	200 029	200 030	200 031	200 032
Permitted load	t	1,5	3	5	10
Overall high	mm	725	725	725	800
Lift	mm	350	350	300	300
Weight	kg	16,5	22	32	52

haacon policy is one of continuous development. We reserve the right to amend specifications without notice or obligation.

3. GENERAL

These high quality rack jacks, produced for decades, are robust and reliable and are available in capacities of 1.5 to 10 tonnes normal and short versions.

4. CONSTRUCTION

Indestructable rack jacks with lifting housing. Spur gear in special steel, hardened or tempered. The gear mechanism of this rack jack range complies with German VBG 8 safety regulations for lifting and pulling equipment.

Typ 1188: The claw is adjustable to suit any initial height of load thus avoiding excessive winding up with crank to the desired load height.

The rack jacks are available with either "SIKU" safety cranks or "RAKU" ratchet cranks.

SIKU = Safety crank with self-acting friction type load brake with two-part spring loaded detent lever secures the load at any height. By rotating the crank clockwise the load is lifted and vice versa.

RAKU = Ratchet crank. A ratchet mechanism has been added to the above mentioned SIKU crank which allows either lift or lower positions to be selected. Especially useful in areas with restricted head room.

5. OPERATION

Fix the adjustable claw in the desired position with securing pin (Typ 1188).

Unfold the crank handle. Turn crank clockwise to lift the load. To lower the load, turn crank anti-clockwise.

If the crank is not turned the load is suspended safely.

6. MAINTENANCE

The rack jack should be checked regularly by trained personnel depending on usage and conditions, but at least once a year.

Trained personnel are people who by virtue of training and experience have gained sufficient knowledge in the field of rack jacks, lifting and pulling equipment and who are adequately acquainted with national standards of accident prevention and safety regulations and who are able to judge the condition of rack jacks, lifting and pulling equipment where working safety is concerned.

Gear wheels and pinions

The gearbox has been filled with high quality long-life grease by the manufacturer and the bearings are equipped with maintenance free plain bearings. This lubrication will last for approximately 5 years with normal use. If the winch is used frequently then the gearbox should be opened every 2 years, worn parts exchanged and new grease applied.

Safety crank

If the crank offers resistance when lowering a load, apply a few drops of oil into the recesses on the crank hub.

Grease all moving parts on the crank handle if necessary.

The replacement of worn friction discs (aperture > 30°) and repair of faulty cranks may only be carried out by the manufacturer.

WARNING!!

 Do not uncouple crank or detent lever or pawl when jack is loaded.

Last but not least

If the crank cannot be moved after a long period of non-use or due to bad weather try to turn anti-clockwise. Add a drop of oil into the recesses, turn up and down several times until the corrosion inside the brake has been cleared and the crank turns normally.

Follow these instructions and you too will continue to be pleased with your haacon rack jack.

7. SPARE PARTS

The following data should be given with each order:

- Type number and serial number of rack jack / Pos. and Part number.

Power Jacks Ltd.
 South Harbour Road
 Fraserburgh
 AB43 9BZ
 Scotland
 Tel: +44 (0) 1346 513131
 Fax: +44 (0) 1346 516827
 email: sales@powerjacks.com
 http://www.powerjacks.com

Power Jacks Ltd. Authorised Distributor of Equipment
 Manufactured by Haacon Hebetchnik GmbH

Typ 11.1,5

Pos	Teile-Nr. Part-No. Référence	Abmessung Dimensions Dimensions	DIN-Nr. DIN-No. DIN-No.	Stück Qty. Quant.
	200 001 200 007 200 019			
1	113 224 113 219			1
2	102 081 102 081			1
3	102 083 107 466			1
4	103 759 103 759			1
5	102 086 102 086			1
6	102 087 102 087			1
8	102 152 102 152			1
9	102 131 102 131			1
10	101 137 101 137			1
11	101 396 107 467			1
13	100 246 100 246	M 6x16	DIN 933	7
14	100 351 100 351	M 6	DIN 934	7
15	100 368 100 368	M 14	DIN 934	1
16	100 453 100 453	A 6	DIN 127	7
17	100 461 100 461	A 14	DIN 127	1
18	100 721 100 721	A 14x1	DIN 471	1
20	101 404 110 527			1

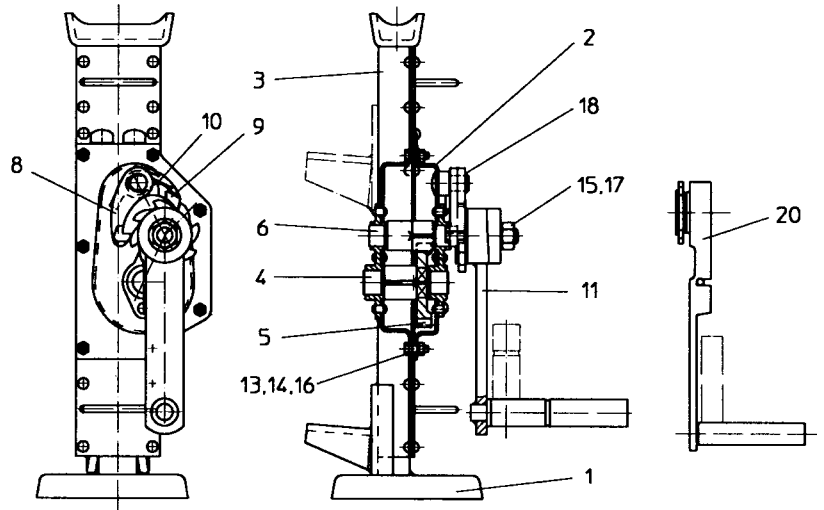

Typ 11.3

Pos	Teile-Nr. Part-No. Référence	Abmessung Dimensions Dimensions	DIN-Nr. DIN-No. DIN-No.	Stück Qty. Quant.
	200 002 200 008 200 020			
1	113 245 113 248			1
2	102 095 102 095			1
3	102 098 107 470			1
4	103 761 103 761			1
5	102 101 102 101			1
6	102 102 102 102			1
7	100 191 100 191	M 8x20	DIN 933	7
8	100 455 100 455	A 8	DIN 127	7
9	100 355 100 355	M 8	DIN 934	7
10	100 368 100 368	M 14	DIN 934	1
11	100 461 100 461	A 14	DIN 127	1
12	101 137 101 137			1
13	100 721 100 721	A 14x1	DIN 471	1
14	102 152 102 152			1
15	102 131 102 131			1
20	101 396 101 396			1
21	101 404 101 404			1

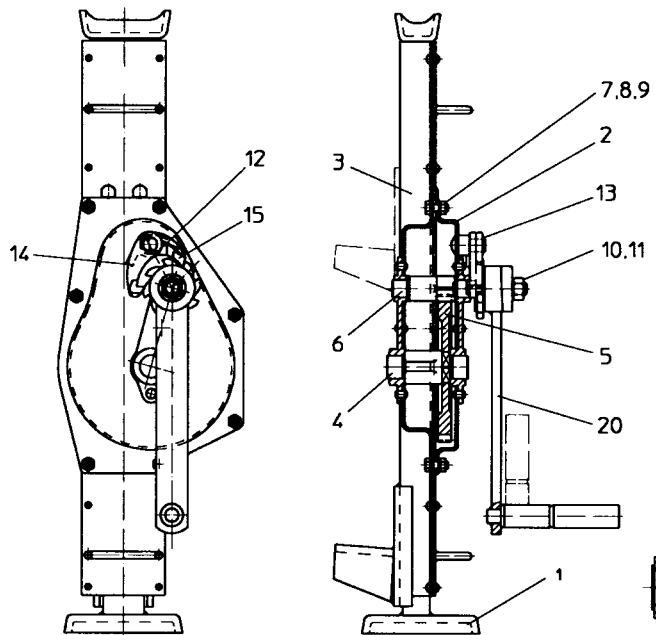

Typ 11.5

Pos	Teile-Nr. Part-No. Référence	Abmessung Dimensions Dimensions	DIN-Nr. DIN-No. DIN-No.	Stück Qty. Quant.
	200 003 200 009 200 021			
1	114 493 114 493			1
2	102 114 102 114			1
3	102 116 102 116			1
4	102 481 102 481			1
5	102 119 102 119			1
6	102 122 102 122			1
7	102 123 102 123			1
8	102 120 102 120			1
10	102 152 102 152			1
11	102 131 102 131			1
12	101 137 101 137			1
13	101 396 101 396			1
15	100 191 100 191	M 8x20	DIN 933	8
16	100 455 100 455	A 8	DIN 127	8
17	100 461 100 461	A 14	DIN 127	1
18	100 355 100 355	M 8	DIN 934	8
19	100 368 100 368	M 14	DIN 934	1

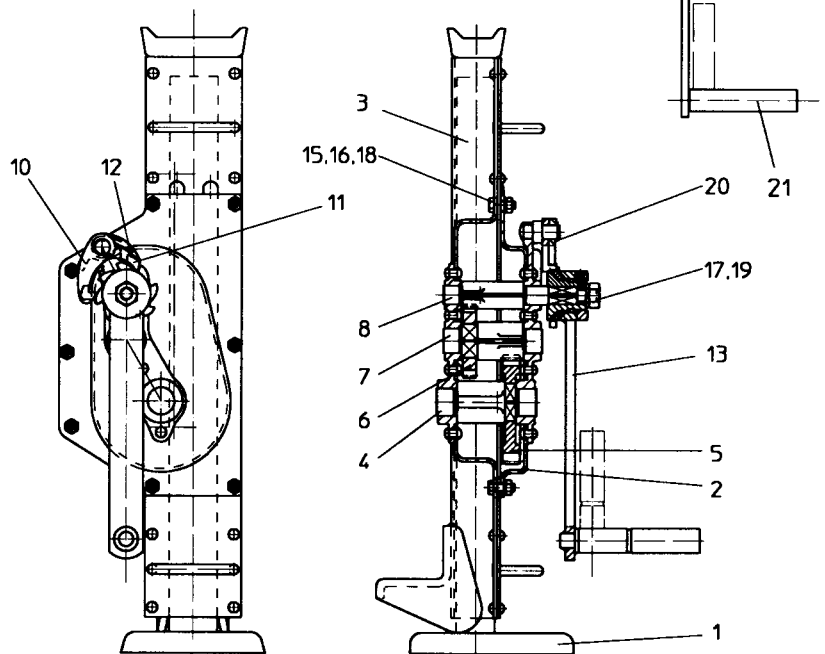

Typ 11.10

Pos	Teile-Nr. Part-No. Référence	Abmessung Dimensions Dimensions	DIN-Nr. DIN-No. DIN-No.	Stück Qty. Quant.
	200 004 200 010	200 016 200 022		
1	115 021	115 022		1
2	102 157	102 157		1
3	102 160	107 476		1
4	102 162	102 162		1
5	102 163	102 163		1
6	102 166	102 166		1
7	102 167	102 167		1
8	102 164	102 164		1
10	102 152	102 152		1
11	102 174	102 174		1
12	101 137	101 137		1
13	101 398	101 398		1
15	100 203	100 203	M 10x25 DIN 933	8
16	100 457	100 457	A 10 DIN 127	8
17	100 463	100 463	A 16 DIN 127	1
18	100 361	100 361	M 10 DIN 934	8
19	100 369	100 369	M 16 DIN 934	1

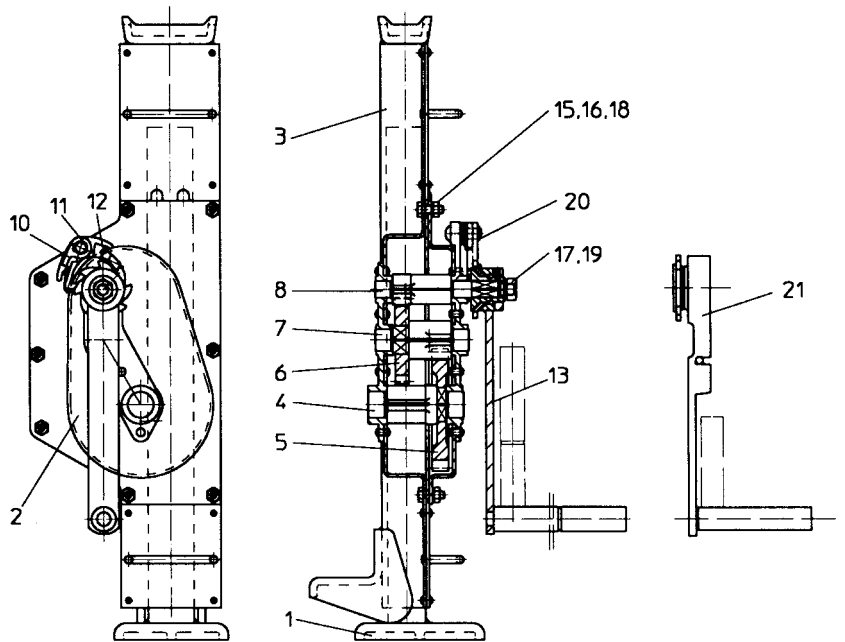

Typ 1188.10

Pos	Teile-Nr. Part-No. Référence	Abmessung Dimensions Dimensions	DIN-Nr. DIN-No. DIN-No.	Stück Qty. Quant.
	200 028 200 032			
1	115 021			1
2	102 157			1
3	107 443			1
4	101 329			1
5	101 398			1
6	102 162			1
7	102 163			1
8	102 164			1
9	102 167			1
10	102 166			1
11	102 152			1
12	102 174			1
13	100 369	M 16 DIN 934		1
14	100 203	M 10x25 DIN 933		7
15	100 457	A 10 DIN 127		8
16	100 463	A 16 DIN 127		1
17	100 721	A 14x1 DIN 471		1

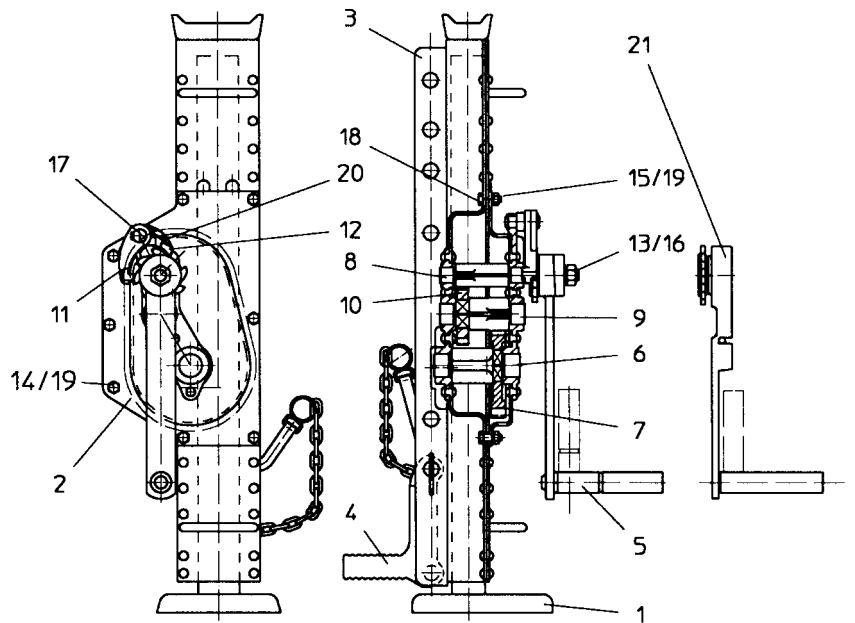

Typ 1188.1,5

Pos	Teile-Nr. Part-No. Référence	Abmessung Dimensions Dimensions	DIN-Nr. DIN-No. DIN-No.	Stück Qty. Quant.
	200 025 200 029			1
1	113 224			1
2	102081			1
3	107 439			1
4	101 325			1
5	103759			1
6	102 086			1
7	102 087			1
8	102 152			1
9	102 131			1
10	101 137			1
11	101 396	M 6x16	DIN 933	7
13	100 246	M 6	DIN 934	7
14	100 351	M 14	DIN 934	1
15	100 368	A 6	DIN 127	7
16	100 453	A 14	DIN 127	1
17	100 461	A 14x1	DIN 471	1
18	100 721			1

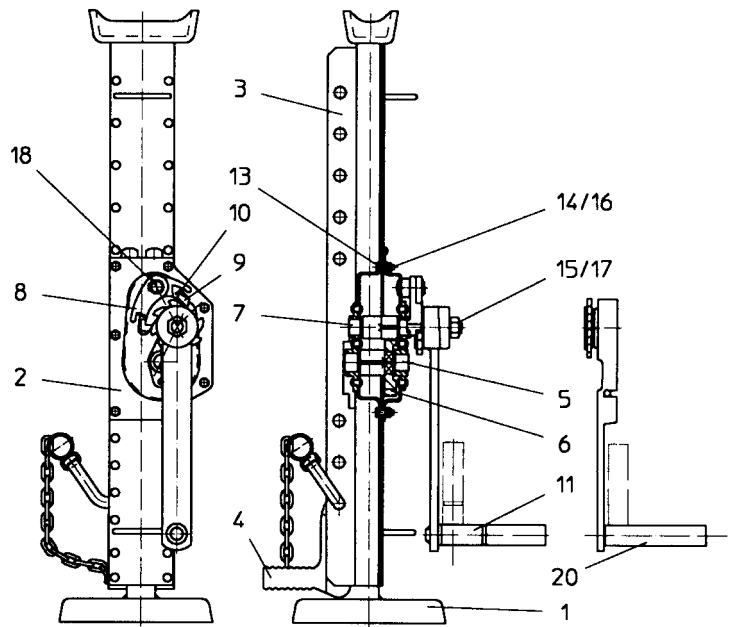

Typ 1188.3

Pos	Teile-Nr. Part-No. Référence	Abmessung Dimensions Dimensions	DIN-Nr. DIN-No. DIN-No.	Stück Qty. Quant.
	200 026 200 030			
1	113 245			1
2	102095			1
3	103 728			1
4	101 325			1
5	103761			1
6	102 101			1
7	102 102			1
8	100 191	M 8x20	DIN 933	7
10	100 455	A 8	DIN 127	7
11	100 355	M 8	DIN 934	7
12	100 368	M 14	DIN 934	1
13	100 461	A 14	DIN 127	1
14	101 137			1
15	100 721	A 14x1	DIN 471	1
16	102 152			1
17	102 131			1
20	101 396			1

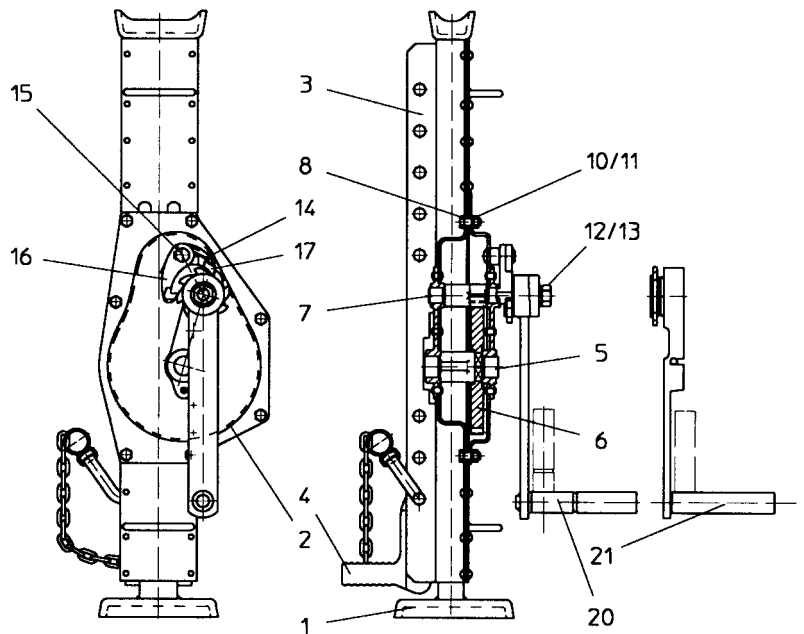

Typ 1188.5

Pos	Teile-Nr. Part-No. Référence	Abmessung Dimensions Dimensions	DIN-Nr. DIN-No. DIN-No.	Stück Qty. Quant.
	200 027 200 031			
1	114493			1
2	102 114			1
3	107 441			1
4	101 328			1
5	102 481			1
6	102 119			1
7	102 122			1
8	102 123			1
9	102 120			1
10	102 152			1
11	102 131			1
12	101 137			1
13	101 396			1
15	100 191	M 8x20	DIN 933	8
16	100 455	A 8	DIN 127	8
17	100 461	A 14	DIN 127	1
18	100 355	M 8	DIN 934	8

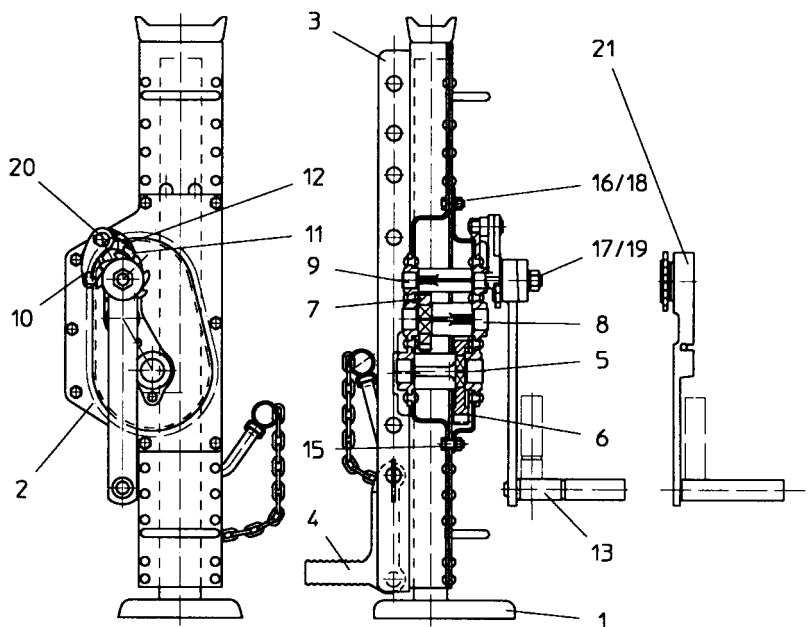

**E.C. Declaration of Conformity
to 98/37/EEC IIA**

haacon hebetchnik gmbh
Josef-Haamann-Straße 6
D-97896 Freudenberg/Main



Name and address:

haacon hebetchnik gmbh
Josef-Haamann-Straße 6
97896 Freudenberg/Main

Telefon: 09375/84-0
Telefax: 09375/8466

Description:

Designation: Rack jack
Type: 11 S, 11 R, 11 KS, 11 KR, 1188 S, 1188 R
Capacities 1,5 – 3 – 5 – 10 – 15 – 20 t

Relevant E.C. Directives:

98/37/EEC	EC-machinery directive
91/368/EEC	EC-machinery directive
93/44/EEC	EC-machinery directive
93/68/EEC	EC-machinery directive

Harmonised standards:

EN292 parts 1 & 2 safety of machines

National standards and technical specifications:

VBG 1 Unfallverhütungsvorschriften (Allgemeine Vorschriften)
VBG 8 Unfallverhütungsvorschriften (Winden, Hub-Zuggeräte)
DIN 7355 Stahlwinden

Signed:

Freudenberg, 08.10.01

ppa.. F. Hartmann

i.V. K. Lazarus