



# **POWER JACKS**

## **GB Operation Instructions**

Type            8214.0,5

Universal Extendible Lifting Jack

Power Jacks Ltd. Authorised Distributor of Equipment

Manufactured by Haacon Hebeteknik GmbH

Power Jacks Ltd., South Harbour Road, Fraserburgh AB43 9BZ Scotland

Tel: +44 (0) 1346 513131    Fax: +44 (0) 1346 516827

email: [sales@powerjacks.com](mailto:sales@powerjacks.com)    <http://www.powerjacks.com>



## **Contents**

1. Safety Instructions
2. Technical Data
3. General
4. Construction / Function
5. Installation
6. Operation
7. Maintenance
8. Testing
9. Spare parts



## 1. Safety Instructions

### **Where to use this universal extendible lifting jack**

This spindle jack may only be used in accordance with the following operating instructions.

- to be used only to lift, lower, grip and shift freely moving loads by push loading.
- to be used only if in perfect technical condition.
- to be used by trained personnel only.

### **Safe working practices**

Read these operating instructions carefully before using the spindle jack.

Work safely and be aware of dangers at all times.

Before use as a lifting jack ensure ground surface is clear and safe.

Check that jack is vertical.

Do not exceed stated crank force when used as a vice or clamp.

Inform your supervisor immediately of any damage or faults to the spindle jack.

Do not operate the spindle jack again until the damage or fault has been repaired.

### **Do not:**

- exceed the maximum load (see tech. data and type-/capacity number plate).
- lift people.
- Working above lifted loads.
- put on a second extension set.

### **Supervision:**

- ensure that these operating instructions are always at hand.
- do not allow this spindle jack to be operated by untrained staff.
- check regularly that the spindle jack is operated safely and according to these instructions.

### **Installation, Maintenance and Repair**

Installation, maintenance and repair may only be carried out by trained personnel.

Use only original manufacturer's replacement parts.

No changes or modifications may be carried out on parts relevant to safety.

Additional equipment must not infringe on safety.

### **Additional instructions to be adhered to:**

- Safety and accident prevention regulations.
- National regulations, safety standards and guidelines.

## 2. Technical Data

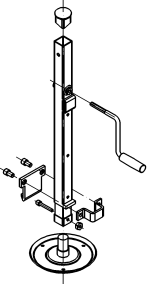
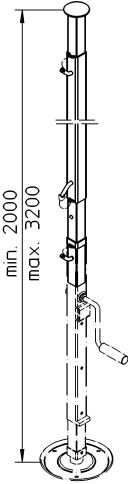
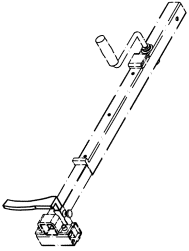
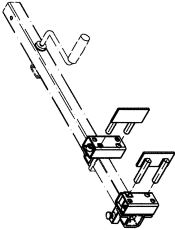
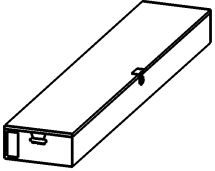
Type	Standard equipment	Accessories:			
		Extension set	Clamp	Vice	Galvanised metal Case: 000 095
	205 320	205 425	204 811	205 426	
Permitted load	0,5 t	0,25 t			
Permissible supporting load	0,8 t	0,25 t			
O/A height	640 mm	to 3200 mm			
Lift	250 mm				
Lift/crank turn	3 mm				
Crank force	140 N				
Weight	6,5 kg	6,8 kg	0,5 kg	2,7 kg	5,3 kg
					

### **3. General**

The manually-operated spindle jack is the basic element of the construction kit. The sturdy and easy to assemble rectangular tube of the spindle jack guarantees versatile addition and installation options and thus universal application.

The self-locking trapeze spindle and maintenance-free bevel gears ensure safe and easy operation.

Using the extra parts, the hoisting unit can be converted for use as a gripping or support unit.

The unit meets the VBG 8 accident prevention standards.

### **4. Construction/function**

#### **Standard equipment**

Using the manual crank the trapeze spindle is run via a bevel gear system.

Because of the stationary nuts this causes a slow linear movement. To protect against mechanical damage, the spindle and moving parts are located in extendible rectangular tubes which also ensure a high level of stability.

#### **Extension set**

This consists of extendible rectangular tubes and can be attached to the spindle jack.

It can be used to assist with assembly and for ceiling support.

#### **Vice**

The construction parts are screwed onto the spindle jack and mounted. The unit can be used as a vice.

#### **Clamp**

An attachable part to use for clamping long parts.

#### **Transport case**

All parts can be stored in the transport case.

## 5. Assembly

### Assembly of parts

#### 5.1 Standard equipment

- In this model force can be directed over the spindle head 5. Place spindle jack 1 on base plate 2, and fasten with screw 3 and nut 4.  
Insert head 5 into spindle jack 1.  
Insert crank 6 (can be done from either side).
- In this model force can be directed over the claw. Place claw 7 at the desired level on spindle jack 1, connect with clamp 8, tighten with cylinder screw 9.  
Insert crank 6.

#### 5.2 Extension set

The spindle jack stands on the base plate. Remove head 5. Insert rectangular tube 10 into the opening on the head of the spindle jack, and tighten with pin connections and spring callipers.

Slide rectangular tube 11 over rectangular tube 10, fasten at the desired level with pin connections and secure with spring callipers. Rectangular tube 11 can be built in back to front. Slide rectangular tube 12 into rectangular tube 11 at the desired level, tighten with pin connections and secure with spring callipers.

The unit can be used as a support or an assembly aid for ceilings.

#### 5.3 Vice

All loose parts should be removed from the spindle jack. Screw vice grip 13 and clamp 14 onto the extendible tube of spindle jack 1 with a cylinder screw. Screw vice grip 15 and clamp 16 to the outermost rectangular tube in the desired position with cylinder screw 17. Insert vice 18 into the vice grip. The spindle jack thus prepared can be clamped to a table, for example using a clamping device to a table.

With this added equipment work can be done as on a vice.

## 5.4 Clamp

The vice grip 13 attached to the extendible rectangular tube of spindle jack 1 is located on the spindle jack. All other additional parts are removed. In the rectangular opening of the vice grip, clamp 19 is placed. The spindle jack can be screwed, to a table or other work surface with a clamping device.

Using the clamp, overlong parts can be pressed up against a stop and worked on there.

## 5.5 Case

All loose parts can be stored in the case 20. Only the tube of the extension parts extends beyond the length of the case. The case can be locked with a padlock. Its total weight is less than 25 kg. The handles make it easy to lift and transport.

## 6. Operation

With regard to all operations, movement runs via the spindle jack. The spindle jack is extended by turning the crank clockwise. To retract turn counter-clockwise. When the hoist capacity is reached (crank pressure increases!), cranking should be stopped in order to prevent damage to the jack. When the crank is released, the load will be held in any desired position by the self-locking spindle.

### **Attention!**

Only add parts to the unloaded spindle jack.

## 7. Maintenance

The spindle jack should be cleaned as necessary, at least every six months.

In the factory the bevel gear drive is filled with long-lasting grease which at normal use (1-3 times a day) will ensure sufficient lubrication.

## 8. Inspection

The spindle jack and its additional parts must be inspected according to usage specifications and the operating situation, but in any case at least once a year, by an expert (annual operational security check as per VBG 8, § 23, Sec. 2 accident prevention guidelines).

Experts are persons who, on the basis of their professional training and experience, have sufficient knowledge in the area of jacking, lifting and towing equipment and are familiar with the applicable national industrial safety guidelines, accident prevention guidelines, standards and generally-recognized engineering regulations (such as DIN and EN standards) to the extent that they can assess the safe operating condition of jacking, lifting and towing equipment. Here the operating and maintenance manual of the manufacturer applies.

If you observe these guidelines you, you can be assured of a correct functioning of your universal spindle and clamping system.

## 9. Spare parts

With ordering spare parts please **a l w a y s** specify:

- Model and factory number of the spindle jack/position and part number