

Upright EMT0010-U00

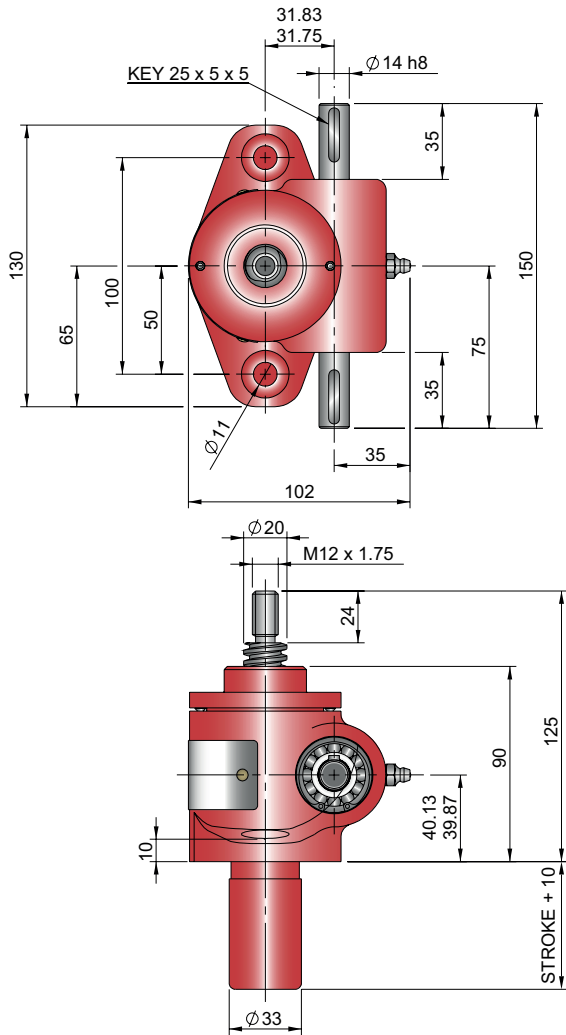

Inverted EMT0010-I00

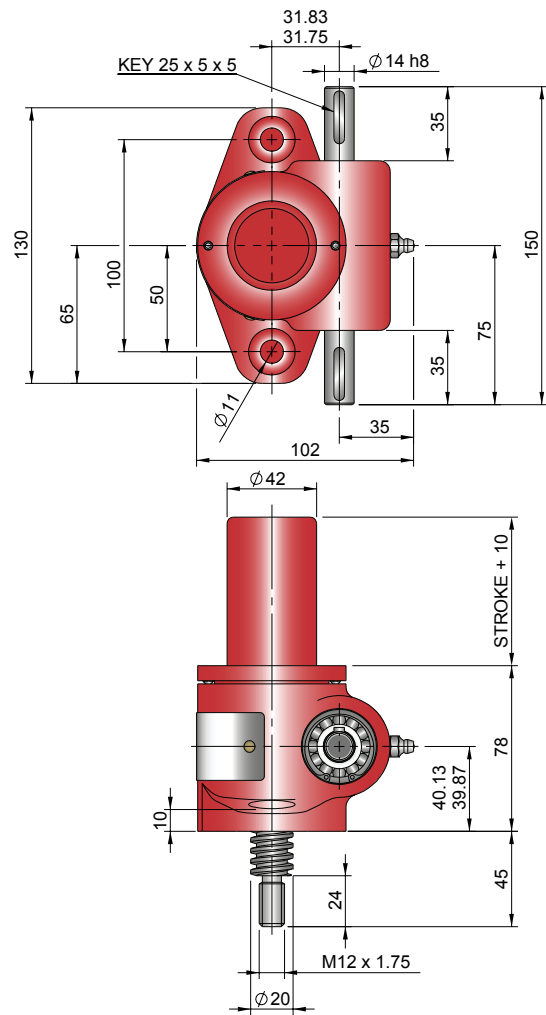

Performance

Model		EMT0010 EMR0010	
Capacity	kN	10	
Lifting Screw	Diameter (mm)	20	
	Lead	Option	1 2
	mm	5	10
Gear Ratio Option 1	Gear Ratio	5:1	
	Static Efficiency	0.233	0.339
	Dynamic Efficiency	0.306	0.424
Gear Ratio Option 2	Gear Ratio	20:1	
	Static Efficiency	0.130	0.192
	Dynamic Efficiency	0.194	0.268
Max. Input power (kW)	Gear Ratio Option 1	0.375	
	Gear Ratio Option 2	0.19	
Start up torque at full load (Nm)	Gear Ratio Option 1	6.8	9.4
	Gear Ratio Option 2	3	4.2

Closed Height

Model		EMT0010 EMR0010	
Capacity	kN	10	
Lifting Screw Lead (mm)		5	10
Turn of worm for travel of lifting screw	Gear Ratio 1	1 Turn	1mm 2mm
	Gear Ratio 2	4 Turn	1mm 2mm
Maximum Through Torque (Nm)		20	
Lifting Screw Restraining Torque (Nm)		22	30
Worm Shaft Maximum Radial Load (N)		325	
Maximum Input Speed (rpm)		1800	
Gear Case Material		Aluminium	
Weight (kg) - stroke = 150mm	EMT	2.36	
	EMR	2.6	
Weight (kg) - per extra 25mm stroke	EMT	0.11	
	EMR	0.05	

Note: All dimension in millimetres unless otherwise stated.
Designs subject to change without notice

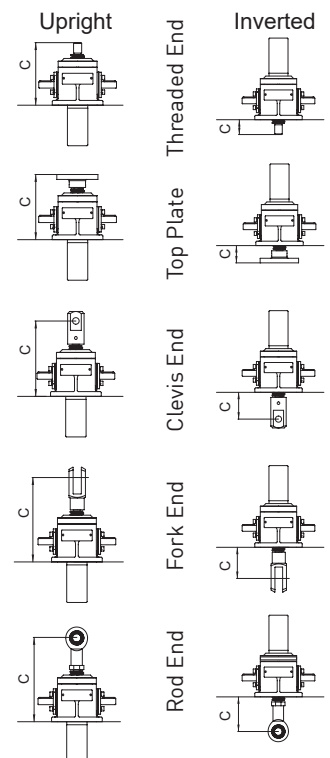

Upright EMR0010-U00

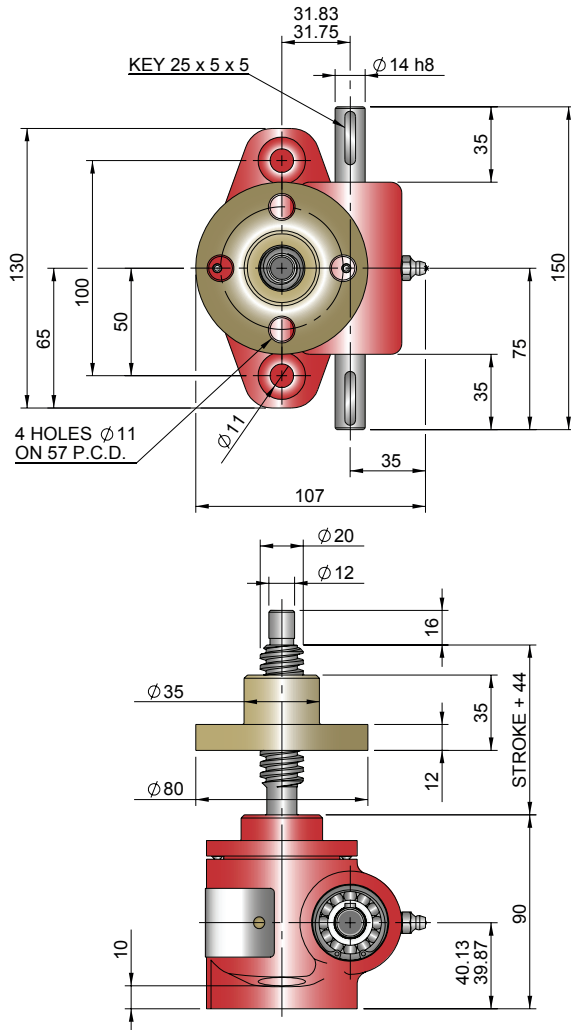

Inverted EMR0010-I00

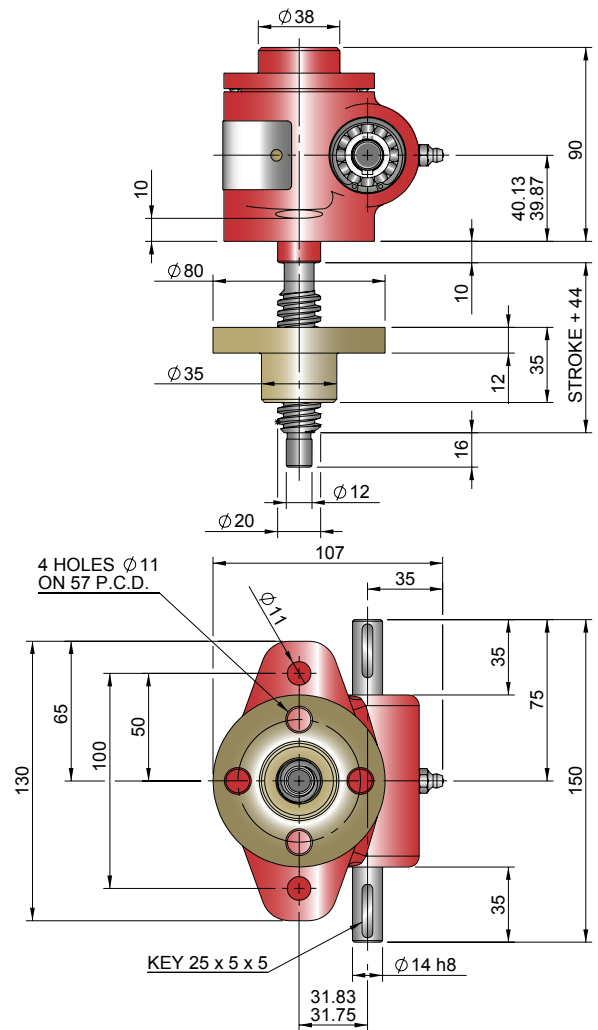

Closed Height & Bellows Boots

Closed Height "C"	Threaded End		Top Plate		Clevis End		Fork End		Rod End	
	Upright	Inverted	Upright	Inverted	Upright	Inverted	Upright	Inverted	Upright	Inverted
EMT0010	125	45	125	45	145	65	148	98	150	70
Stroke (mm)	EMT0010 with Bellows Boots									
0-150	125	75	125	75	145	95	148	98	165	115
151-300	130	95	130	95	150	115	153	118	170	135
301-600	140	95	140	95	160	115	163	118	180	135
751-1000	-	-	-	-	-	-	-	-	-	-

Model	A	B	D	E	G
EMT0010	30	70	15	15	110

Stroke	1-150	151-300	301-600	601-900	901-1050
EMT0010	8	20	35	-	-

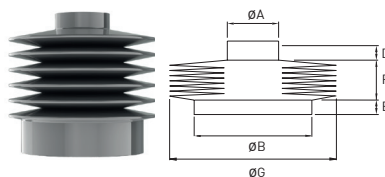

Column Strength

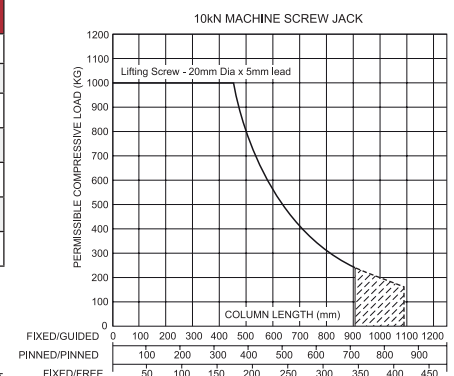

Note:

- 1 Inverted Screw Jacks - Bellows Boot Closed Height assumes screw jack mounted on a structure with thickness = 15mm
- 2 Inverted Screw Jacks - Recommended bellows boot mounting plate $\text{ØB} \times [\text{E} + 5\text{mm}]$ thick.
- 3 Inverted Screw Jacks - Screw Jack mounting plate & bellows boot mounting plate are customers own supply
- 4 † Control tapes fitted (increase outer diameter by 20mm approximately).
- 5 For horizontal installations with than 450 mm of stroke, internal boot guides are recommended.
- 6 Customers with threaded end screw jacks must provide a fixing for the unattached bellows boot collar.
- 7 Bellows boots for Rotating Screw Jacks, other sizes, stroke and materials please consult Power Jacks.

