

C-Series

Machine Screw Jack

MM-SJCMS-EN-01

Operation & Maintenance Instructions with Parts List

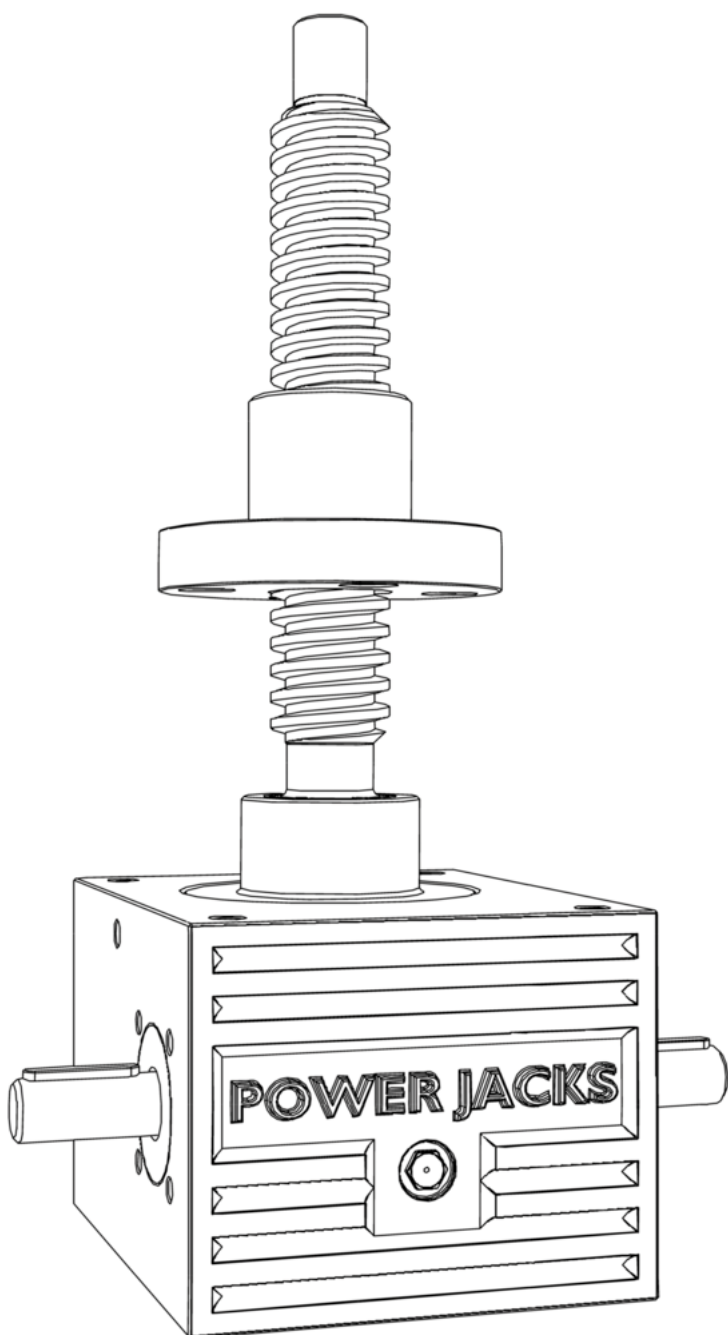

Contents

C-SERIES

MACHINE SCREW JACKS

SPARES LIST & MANUAL

MM-SJCMS-EN-00

1	Introduction.....	4
2	Product Code	8
3	Standard Performance	9
4	Installation	10
5	Operation	15
6	General Maintenance.....	21
7	Recommended Lubricants	26
8	Spare Parts	27
9	Storage & Warehousing.....	28
10	Disposal of Units.....	29
11	Warranty.....	30
12	General Assembly & Parts List	31

1.1 Translating Configurations

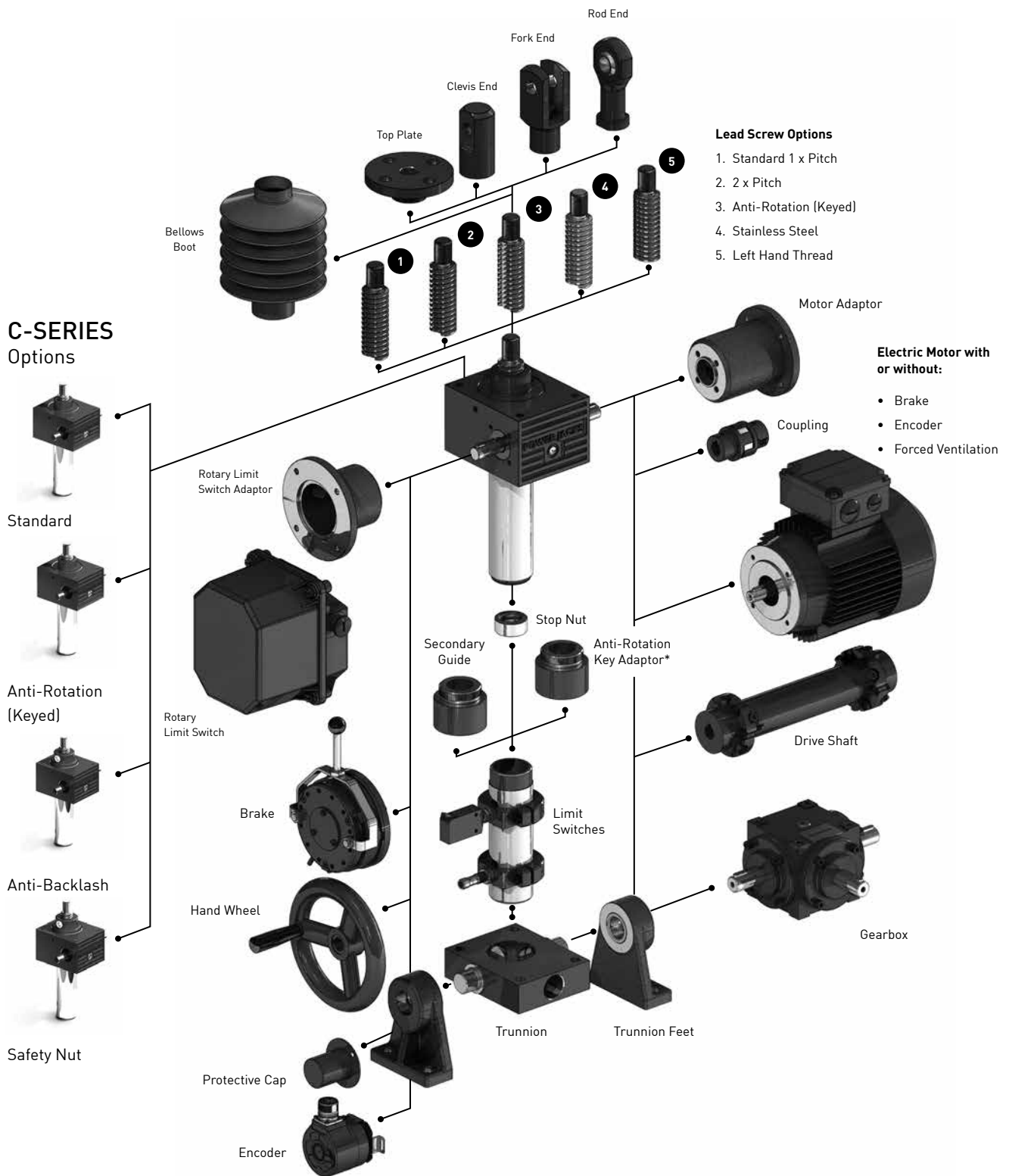

1.2 Rotating Configurations

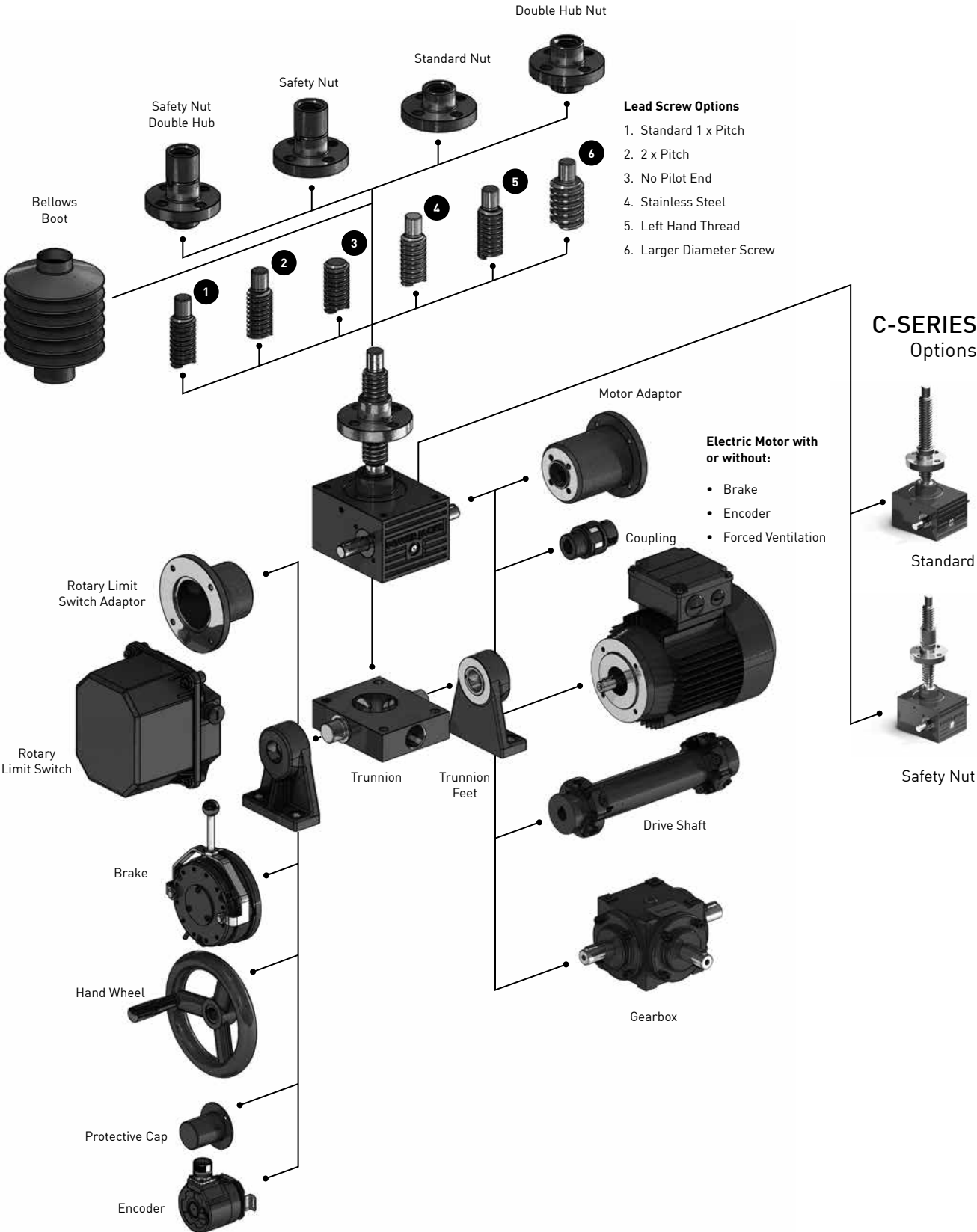

1.3 Introduction

C-Series screw jacks are exclusively designed for carrying out linear motion movements in accordance with the specification detailed in Power Jacks product information and this maintenance manual.

Any other application other than specified or one going beyond the above mentioned capacity is unauthorised. The manufacturer is not liable for damages resulting from such applications. The user alone has to bear the risk.

Since the screw jacks can be applied in various areas, the user is responsible for the specific application of use.

The C-Series machine screw jacks have been designed to comply with Machinery Directive 2006/42/EC and with the relevant essential health and safety requirements as applies to the equipment itself. Where fitted, Electric Motors conform with Low Voltage Directive 2006/95/EC and EMC Directive 2004/108/EC.

1.4 Safety Instructions in The Operating Manual



This symbol indicates potential dangers to people.
Comply with the instructions in order to avoid injury.



This symbol indicates potential dangers to the unit.
Comply with the instructions in order to avoid damage to the unit.



This symbol indicates special information on:

- The best possible use of the unit
- How to facilitate operation of the unit

1.5 Residual Risk and Hazards

- 1.5.1 Should a risk of damage to material or injury to persons remain despite the structural safety of the C-Series screw jack(s), the user must draw attention to such hazards by means of suitable warning notices and written instructions indicating safety precautions.

1.6 Operating Personnel

- 1.6.1 The C-Series screw jacks are designed according to state-of-the-art technology and are in line with applicable safety regulations. However, the general risks of personal injury or damage to property connected with the use of such machinery cannot be completely eliminated. Therefore the units may only be assembled and operated by competent and qualified personnel and only be used for the authorised application.
- 1.6.2 Therefore a careful study of this operating manual should be made before attempting to use or service the unit and particular attention should be paid to the safety instructions.
- 1.6.3 Work to be performed on electrical parts, such as:
- Installation of limit switches
 - Mounting of the drive
 - Check of the direction of rotation
- should only be carried out by qualified electricians.
- 1.6.4 The C-Series screw jacks and the installation should be inspected by the operating and supervising personnel for externally visible damage and defects at least once every shift. Any changes (including the operational conditions) which may affect the safety are to be reported immediately.

2.0 Example

1	2	3	4	5	6	-	7	8	9	10	-	11	12	13	14	-	15	16	17	18	-	19	20	21	22	-	23	24	25
C	M	T	0	2	5	-	0	7	5	0	-	T	B	1	1	-	0	0	P	T	-	0	0	0	B	-	3	P	0

[1] - Screw Jack Type

C = C-Series Screw Jack

[2] - Screw Type

M = Machine Screw

[3] - Screw Configuration

T = Translating Screw

R = Rotating Screw

[4,5,6] - Capacity (kN)

010 = 10kN

025 = 25kN

050 = 50kN

100 = 100 kN

[7,8,9,10] - Stroke (mm)

e.g. 0750 = 750mm

[11] - End Type

E = Threaded End

C = Clevis

T = Top Plate

F = Fork End

R = Rod End

A = Plain End^{#9}P = Pilot End^{#1}N = No Pilot^{#1}**[12] - Gearbox Mounting**

B = Base Mount

T = Trunnion Mount

Standard #2

U = T + Trunnion Feet

X = Trunnion Mount 90°^{#3}

Y = X + Trunnion Feet

[13] - Lead Screw Pitch1 = Option 1 Lead^{#4}2 = Option 2 Lead^{#4}3 = Option 1 Left Hand^{#5}4 = Option 2 Left Hand^{#5}**[14] - Gear Ratio**

1 = Option 1 ratio

2 = Option 2 ratio

[15] - Features

0 = None

K = Anti-Rotation (keyed)

C = Secondary Guide

R = Anti-Backlash

Y = Anti-Backlash & Anti-

Rotation (keyed)

H = Double Hub Nut^{#1}**[16] - Cover Pipe**

0 = Cover Pipe

N = No Cover Pipe

[17] - Stop Nut

0 = No Stop Nut

P = Full Power Stop Nut

[18] - Safety Nut

0 = No Safety Nut

T = Safety Nut Tension

C = Safety Nut Compression

[19] - Worm Shaft Type

0 = Standard Material

N = Nickel Plated

C = Chrome Plated

S = Stainless Steel

[20] - Worm Shaft Ends

0 = Both

L = Left Hand Side Only

R = Right Hand Side Only

[21] - Lead Screw Material

0 = Standard

S = Stainless Steel

L = Large Diameter^{#1 #8}

T = Large Diameter Stainless

Steel^{#1 #8}**[22] - Lead Screw Cover**

0 = None

B = Bellows Boot (fabric)

[23] - Drive

0 = Side Bolt Holes - Both

Sides

M = Motor^{#6, #8}B = Brake Motor^{#6, #8}

H = Hand Wheel

1 = Side Bolt Holes - LHS

2 = Side Bolt Holes - RHS

3 = No Side Bolt Holes

A = Motor Adapter^{#6, #8}**[24] - Limit Switch^{#7, #8}**

0 = None

L = Electro-Mechanical Limit

Switch

R = Rotary Cam Limit Switch

P = Proximity Sensor

[25] - Extra Design^{#8}

0 = None

S = Design Notes

Notes:

#1. Rotating screw models only.

#2. Trunnions on same side as worm shaft (standard).

#3. Trunnions at 90° to worm shaft.

#4. Standard right hand thread form. Worm shaft turns clockwise to extend screw.

#5. Left hand thread form. Worm shaft turns anti-clockwise to extend screw.

#6. Includes motor adapter and coupling. IEC motor adapter is standard.

#7. Limit switch mounting included.

#8. Design notes required to detail device/item specification.

#9. Plain end "A" has same dimensions as "E - threaded end" except no thread form.

Screw Jack Model ⁴		CM-010		CM-025		CM-050		CM-100	
Capacity (kN)		10		25		50		100	
Lead Screw ¹	Diameter (mm)	20		30		40		55	
	Lead (mm)	5	10	6	12	9	18	12	24
Gear Ratios	Option 1	5:1		6:1		6:1		8:1	
	Option 2	20:1		24:1		24:1		24:1	
Turn of worm for travel of lead screw	Option 1 1 Turn	1mm	2mm	1mm	2mm	1.5mm	3mm	1.5mm	3mm
	Option 2 4 Turn	1mm	2mm	1mm	2mm	1.5mm	3mm	2mm	4mm
Maximum Input Power (kW)	Option 1	0.375		1.5		3		3.75	
	Option 2	0.19		0.375		0.55		1.125	
Start up torque at full load (Nm) ²	Option 1	6.8	9.4	19.8	26.4	56.0	76.0	115.9	156.6
	Option 2	3.0	4.1	8.7	11.7	25.5	34.7	60.5	81.9
Maximum Through Torque (Nm) ⁷	Option 1	20.4		59.4		168.0		347.7	
	Option 2	9.0		26.1		76.5		181.5	
Static Efficiency ³	Option 1	0.236	0.339	0.201	0.302	0.213	0.314	0.206	0.305
	Option 2	0.133	0.192	0.113	0.171	0.117	0.172	0.132	0.195
Dynamic Efficiency ³	Option 1	0.306	0.424	0.264	0.383	0.281	0.398	0.272	0.388
	Option 2	0.194	0.268	0.167	0.242	0.172	0.244	0.190	0.271
Lead Screw Restraining Torque (Nm) ⁵		22	30	76	102	210	290	575	780
Worm Shaft Radial Load (N) ⁶		325		380		740		1000	
Maximum Input Speed (rpm)		1800		1800		1800		1800	
Gear Case Material		Aluminium		SG Iron		SG Iron		SG Iron	
Weight (kg) - stroke = 150mm	Translating	3.0		8.3		19.5		36.0	
	Rotating	3.1		8.7		20.2		40.2	
Weight (kg) - per extra 25mm	Translating	0.11		0.21		0.32		0.57	
	Rotating	0.05		0.11		0.19		0.36	

Notes:

1. All metric machine screws have a trapezoidal thread form.
2. For loads of 25% to 100% of screw jack capacity, torque requirements are approximately proportional to the load.
3. Efficiency values for standard grease lubricated worm gear box and lifting screw.
4. All C-Series screw jacks have grease lubricated gearbox and lead screw as standard.
5. Torque required to prevent the lead screw or lead nut from rotating if no anti-rotation device fitted.
6. Radial force applied midway along worm shaft key at 90° to key.
7. Maximum transmittable torque through worm shaft, not through gear set.

4.1 General Installation Notes

4.1.1 Before installing new parts, remove any rust preventative, protection grease etc.

4.1.2 Check before immediate installation for possible transit damage.

4.1.3 Components which have been stored for a long time (over 1 year) should be re-lubricated in working conditions before they are put into operation.

4.1.4 Before putting the C-Series screw jack(s) into service, the User must ensure that the plant in which it is installed complies with all applicable directives, especially those regarding health and safety at work.



4.1.5 Handle the screw jack with care. The C-Series screw jacks should be handled with care to avoid damaging the machined drive shafts and the threads of the lead screw.

4.1.6 Before putting the units into service, check the lubricant level. If necessary top up the lubricant to the required level.



4.1.7 Do not mix greases of different nature or specifications.

4.1.8 If the same type of grease already in use is not available, remove all of the existing lubricant completely and flush its interior thoroughly with a light solvent before refilling with a new lubricant.

4.1.9 The structure on which the C-Series screw jack(s) are mounted have ample strength to carry the maximum load, and should be rigid enough to prevent undue deflection or distortion of the screw jack supporting members.

4.1.10 It is essential that the C-Series screw jack(s) be carefully aligned during installation so that the lead screw is running true and the connecting shafts are exactly in line with the input drive shafts.

4.1.11 When installing several screw jacks to move a common load/item/structure, the jacks should first be connected to the structure (refer 4.4). The load should be equally distributed between the screw jacks. The screw jack input drive shafts should then be connected taking care not to turn the input shaft and lose the screw jack position relative to the structure.

4.1.12 After the C-Series screw jack(s) is installed, shafting, gearboxes, motors, etc., are coupled together it should be possible to turn the main drive by hand (no load on screw jacks). If there are no signs of binding or misalignment, the screw jack system is then ready for normal operation.

4.1.13 After the C-Series screw jack(s) are installed, they should be operated through their full travel four or five times under minimum load conditions. If the arrangement operates satisfactorily and there are no signs of binding or misalignment the C-Series screw jack(s) are ready for normal operation. Refer to section 5 for typical operating performance checks.

4.2 General Instructions for fitting detachable ends on lead screws

In most circumstances the screw jack is delivered with the required end fitting assembled to the unit.

- 4.2.1 It is important that the detachable ends are securely fixed to the lead screws and the following procedure should be adhered to.
- 4.2.2 Thread the detachable end on to the lead screw and tighten up as hard as possible without damaging the components.
- 4.2.3 Select a twist drill which is a free fit in the tapped holes of the detachable end. Using these holes as a drill guide, drill dimple only into the lead screw. Clean out swarf and remove detachable end. Select another drill which matches the set screw diameter and, using the drill dimples as a guide, drill into the lead screw a full diameter depth of 1mm below the root diameter of the threads. Refit detachable end.
- 4.2.4 Fit the knurled point set screws (supplied with detachable ends) firmly in place ensuring that point of set screws make contact with bottom of drill dimples. Secure the set screws with chemical thread locking compound (e.g. Loctite).



- 4.2.5 If screw jacks with keyed lead screws are involved, and it is required to line up the clevis flats or top plate holes, etc., in a fixed relationship to the worm shaft centre line, it will be necessary to face the underside of the detachable end to obtain the required relationship. This operation should be done carefully as only a few hundredths of a mm (thousands of an inch) removed from the attachment is equivalent to a fair amount of rotational movement. After the correct relationship has been obtained with the attachment firmly tightened up, proceed to install the screw jack in accordance with this manual.

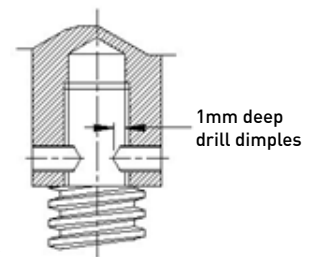

4.3 Unpacking and installation

4.3.1 Remove the C-Series screw jack(s) from their container. Dispose of the packaging material and the desiccant in an environmentally friendly way.

4.3.2 If it is necessary and in order to avoid damages, please use soft straps to transport or mount the screw jack.



4.3.3 For translating screw jacks in order to avoid damages, do not attach the straps to the lead screw but to the lead screw end fitting, cover pipe or to the screw jacks gearbox. Where possible lift vertically.



4.3.4 For rotating screw jacks in order to avoid damages, do not attach the straps to the lead screw but to the nut on the lead screw or to the screw jacks gearbox. Where possible lift vertically.

4.4 Mounting

4.4.1 Before starting assembly work, check the directions of rotation of all jacks, gearboxes and drive motors with regard to the required direction of travel of each jack in the application.

4.4.2 All components must be carefully aligned, as alignment errors increase stress and power consumption and lead to overheating and premature wear.



4.4.3 When installing screw jacks, ensure that the mounting face is flat and square to the guides of the load, to within 0.4/1000 millimetres.

4.4.4 Before attaching the drive unit, the screw jack should be turned through its entire stroke by hand, without load. Variations in the amount of force required and/or marks on the screw or guides indicate alignment errors. Loosen the relevant mounting bolts and adjust positioning until the correct alignment is achieved.

4.4.5 All mounting bolts must be re-tightened after a short period of operation.

4.4.6 Mount the screw jack by fixing the screw jack body to the structure by either its standard base mounting points or via a mounting accessory like a trunnion. The screw end or nut should be fixed to the moving part of the structure (or vice versa).



4.4.7 Verify that the structural attachment that connects to the screw jack end fitting or nut is aligned throughout the screw jack stroke before connecting to the screw jack.



4.4.8 Take care when fitting couplings. A blow on a shaft end could cause gear set damage.



4.4.9 Shaft alignment is critical, check on installation

4.4.10 Bellows Boots



4.4.10.1 Push the bellows over the lead screw and attach the collars with the jubilee clips provided. Be careful not to rip or tear the bellows boot.

4.4.11 Drive Motor

- 4.4.11.1 Power Jacks recommend that when you purchase a screw jack requiring a motor mounted directly to the screw jack this is purchased as a complete item from Power Jacks. The motor is then pre-assembled to the screw jack. If you have opted to fit a motor yourself below is a typical procedure for common motor types.
- 4.4.11.2 Before mounting the drive motor, check the direction of rotation of the screw jack drive shafts relative to the linear motion of its lead screw. Also check the operation of any limit switches fitted to the unit.
- 4.4.11.3 Place the motor into the mounting position next to the screw jack.
- 4.4.11.4 Connect the motor to the power source and switch on the motor. Check the direction of rotation, in association with the safety limit switches (if necessary, change the direction of the motor shaft rotation).
- 4.4.11.5 Attach the motor adapter flange to the shell / body of the screw jack, using 4 set screws.
- 4.4.11.6 Typically a flexible coupling with elastomeric element is used to connect the two drive shafts.
- 4.4.11.7 Attach one hub of the coupling half to the worm shaft of the screw jack.
- 4.4.11.8 Push the elastomeric element (spider insert) onto the coupling hub now on the screw jack.
- 4.4.11.9 Mount the second coupling hub onto the drive shaft of the motor.
- 4.4.11.10 Attach the motor to the motor adapter flange using 4 screws. Remember to radially orientate the motor to the correct position for your application.

4.4.12 Limit Switches – Fitted To Cover Pipe

- 4.4.12.1 Power Jacks recommend that when you purchase a screw jack requiring limit switches mounted directly to the screw jack this is purchased as a complete item from Power Jacks. The limit switches are then pre-assembled to the screw jack provided suitable to transport. However always reset and check limit switch operation when installing the screw jack. The following procedure is for limit switches fitted to the cover pipe of the screw jack with an adjustable clamp ring.
- 4.4.12.2 Detach the corresponding clamping ring on the cover pipe by loosening the mounting bolt.
- 4.4.12.3 Move the limit switch into the desired position.
- 4.4.12.4 Clamp the ring by tightening the mounting bolt.
- 4.4.12.5 Check the position of the limit switch by turning the screw manually and checking that the switches triggers at the desired screw jack stroke position.
- 4.4.12.6 If necessary, repeat the procedure.

4.4.13 Limit Switches – Rotary Cam Type (RLS)

- 4.4.13.1 Power Jacks recommend that when you purchase a screw jack requiring a Rotary cam type Limit Switch (RLS) mounted directly to the screw jack this is purchased as a complete item from Power Jacks. The RLS unit is then pre-assembled to the screw jack. If you have opted to fit a RLS unit yourself below is a typical procedure for common RLS unit types. However always reset and check limit switch operation when installing the screw jack.
- 4.4.13.2 Before mounting the RLS unit, check the direction of rotation of the screw jack drive shafts relative to the linear motion of its lead screw.
- 4.4.13.3 Place the RLS unit into the mounting position next to the screw jack.
- 4.4.13.4 Attach the RLS adapter flange to the shell / body of the screw jack, using 4 set screws.
- 4.4.13.5 Typically a flexible beam coupling is used to connect the two drive shafts.
- 4.4.13.6 Attach the beam coupling to the worm shaft of the screw jack.
- 4.4.13.7 Attach the RLS unit to the adapter flange using 4 screws. Make sure that the drive shaft of the RLS unit fully engages in the beam coupling. Tighten the clamp screw of the beam coupling. Remember to radially orientate the RLS unit to the correct position for your application.



4.5 Regulations

The following regulations must be complied with:



- The relevant local regulations for the prevention of accidents.
- Generally recognized safety regulations.
- National regulations.

5.1 Operational Recommendations

- 5.1.1 Select a screw jack which has a rated capacity greater than the maximum load that may be imposed on it.
- 5.1.2 The screw jacks should have a greater raise than is needed in the actual installation. Should it be necessary to operate the screw jacks at the extreme limits of travel it should be done cautiously.
-  5.1.3 It is important that the lead screws should not be closed below the specified closed height dimension of the screw jacks, otherwise serious damage may result to the worm gear.
-  5.1.4 Lead screw end stops are to prevent over-travel or loss of screw. These are not load supporting and should be treated as an emergency device only and must not be allowed to come into contact with the worm gears during normal working cycles otherwise serious damage will result to worm gears and bearings.
-  5.1.5 The maximum worm shaft speed for these screw jacks should not exceed 500 R.P.M. for heavy loads. Refer to Power Jacks Limited for higher worm shaft speeds for lighter loads.
- 5.1.6 The lead screws should not be permitted to accumulate dust and grit on the threads. If possible, lead screws should be returned to the closed position (retracted) when not in use.
- 5.1.7 If equipped with bellows boot the boot must not be compressed below its minimum height (consult Power Jacks product literature or engineers).

5.2 Operational Features

- 5.2.1 **How a Rotating Screw Jack Works**

The rotation of the worm shaft causes the worm gear to rotate. For rotating screw jacks the lead screw is fixed to the worm gear and they rotate at the same speed. As the worm gear turns, the friction forces on the screw thread act to turn the nut also. The greater the load on the screw jack unit, the greater the tendency of the nut to turn. If the nut turns with the screw, it will not raise the load. Therefore the nut needs to be fixed to a structure to prevent rotation. The restraining torque required for the structure, also known as the "lead screw key torque" can be found in product literature or requested from Power Jacks.
- 5.2.2 **How a Translating Screw Jack Works**

The rotation of the worm shaft causes the worm gear to rotate. For translating screw jacks the worm gear is threaded to accommodate the lead screw thread. As the worm gear turns, the friction forces on the screw thread act to turn the screw also. The greater the load on the screw jack unit, the greater the tendency of the screw to turn. If the screw turns with the nut (worm gear), it will not raise the load. In those cases where a single unit is used, and where the load cannot be restrained from turning, it is necessary to use a screw jack with an anti-rotation mechanism (keyed screw jack). Lead screw key torque (refer to product literature or requested from Power Jacks) must be checked as excessively heavy unguided loads could break the Anti-rotation mechanism (key).

5.2.3 Anti-Backlash Screw Jack – When To Use
For reduced axial backlash of the lead screw in the screw jack select a model with the "Anti-Backlash" mechanism. This is typically used when the load direction changes from tension to compression and minimal axial backlash is required. This design is only available for translating screw jacks. It can be combined with Anti-Rotation mechanism as well.

5.2.4 Input Torque Required for a Screw Jack
The input torque for a single screw jack depends on the load, the worm gear ratio, type of screw (machine screw, ball screw or roller screw) and the pitch of the lead screw. Torque values are listed in the individual product specification charts based on capacity loads. For loads from 25% to 100% of screw jack model capacity, torque requirements are approximately proportional to the load.

Note: The input torque, as well as the efficiency and side load ratings, is the same for both translating screw and rotating screw jacks.



5.2.5 Maximum Input Power & Speed for a Screw Jack
The input power to the screw jacks should not exceed the power rating shown in the specifications table. Maximum input speed in rpm (revolutions per minute) to a screw jacks worm shaft should not exceed 1800 rpm for C-Series screw jacks.

5.2.6 Efficiency of a Screw Jack
Screw Jack model efficiencies are listed in the individual product specification charts.

5.2.7 Expected Life of a Screw Jack
The life expectancy of a screw jacks lead screw, bearings, nut and worm gear set varies considerably due to the extent of lubrication, abrasive or chemical action, overloading, excessive heat, improper maintenance, etc. For detailed life calculations consult Power Jacks Ltd.

5.2.8 Screw Jack with Anti-Rotation (Keyed) Mechanism
This design is only available for translating screw jacks. If the structure/object connected to the lead screw is not prevented from rotating or the lead screw is not always in contact with the structure then a screw jack with an "Anti-Rotation" mechanism (keyed) should be used.

5.2.9 Standard Screw Jacks How To Prevent The Load from Rotating
For multiple screw jack systems, fix the lead screw end fittings (e.g. top plate or clevis) to the common member being lifted by all the units. For single screw jack applications, bolt the lead screw end fitting (e.g. top plate or clevis) to the load and ensure the load is guided to prevent rotation.



A guided load is always recommended to ensure that the screw jack does not receive any side load and so guidance can be scaled suitably for the load without altering the screw jack design unnecessarily. Note that an external guidance system can provide a higher restraining "key" torque than compared to an anti-rotation mechanism in a screw jack.



5.2.10 Self-Locking of Screw Jacks
Screw Jacks with 24:1 gear ratios are considered self-locking in most cases. Consult Power Jacks for a recommendation specific to your application.

All screw jacks with double start lifting screws are considered not to be self-locking.

Screw Jacks considered not self-locking will require a brake or other holding device.



5.2.11 Shock Loads on a Screw Jack

Shock loads should be eliminated or reduced to a minimum, if they cannot be avoided, the screw jack model selected should be rated at twice the required static load.

For severe shock load applications, use the E-Series, S-Series or M-series screw jacks, the load bearings here can be replaced with heat-treated steel thrust rings which is an option available from Power Jacks. Note this will increase the input torque by approximately 100%.

5.2.12 Axial Backlash in a Screw Jack

5.2.12.1 Backlash in Standard Machine Screw Jacks

Machine screw jacks have backlash due not only to normal manufacturing tolerances, but to the fact that there must be some clearances to prevent binding and galling when the screw jack unit is under load. Usually, the axial backlash is not a problem unless the load on the screw jack unit changes between compression and tension. If a problem does exist, then a unit with the anti-backlash feature should be considered.

5.2.12.2 Screw Jacks with the Anti-Backlash Device

The anti-backlash device reduces the axial backlash between the lead screw and nut assembly to a regulated minimum. As the backlash will increase as the lead screw thread on the gear wears the anti-backlash device can be adjusted to remove this normal condition.

5.2.13 How the Anti-Backlash Device Works

When the screw (1) is under a compression load, the bottom of its thread surfaces are supported by the top thread surfaces of the worm gear (2) at point (A). The anti-backlash nut (3), being pinned to the worm gear and floating on these pins and being adjusted downward by the shell cap, forces its bottom thread surfaces against the upper thread surfaces of the lifting screw at point (B). Thus, backlash between worm gear threads is reduced to a regulated minimum.

When wear occurs in the worm gear threads and on the load carrying surfaces of the lifting screw thread, the load carrying thickness of the worm gear thread will be reduced. This wear will create a gap at point (B) and provide backlash equal to the wear on the threads.

Under compression load, the lifting screw will no longer be in contact with the lower thread surface of the anti-backlash nut. Under this condition, backlash will be present when a tension load is applied.

The anti-backlash feature can be maintained simply by adjusting the shell cap until the desired amount of backlash is achieved.

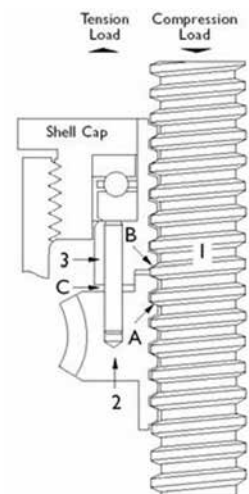

To avoid binding and excessive wear do not adjust lifting screw backlash to less than 0.025mm (0.001"). This will reduce the calculated separation (C) between the anti-backlash nut and worm gear and will reduce the backlash between the worm gear threads and the lifting screw to the desired minimum value.

When separation (C) has been reduced to zero, wear has taken place. Replace the worm gear (2) at this point. This feature acts as a built in safety device which can be used to provide wear indication for critical applications.

5.2.14 Column Strength of the Screw Jack

Column strength of a screw is determined by the relationship between the screw length and its diameter. For column strength charts consult product literature or Power Jacks.

- 5.2.15 **Side Loads on a Screw Jack**
Screw jacks are designed primarily to move and position loads and any side loads (loads not acting axially on lead screw) should be avoided. The units will withstand some side loads, depending on the diameter of the lifting screw and the extended length of the lifting screw. Where side loads are present, the loads should be guided and the guides, rather than the screw jacks, should take the side loads - particularly when long raises are involved. Even a small side load can exert great force on the housings and bearings and increase the operating torque and reduce the life expectancy.
- 5.2.16 **Allowable Duty Cycle of Screw Jack**
Because of the efficiency of conventional worm gear screw jacks, the duty cycle is intermittent at rated load. At reduced loading, the duty cycle may be increased. The high performance S-Series screw jacks have higher thermal efficiencies allowing generally 50% higher duty cycles than conventional worm gear screw jacks. For detailed analysis consult Power Jacks Ltd.
-  5.2.17 **Maximum Operating Temperatures For C-Series Screw Jack**
Normal operation at ambient temperatures of up to 90°C. Operations above 90°C will require special lubricants. For temperatures above 90°C, the life of even special lubricants is limited. Therefore consult Power Jacks on your application. For temperatures above 90°C, advise Power Jacks of full particulars of the duration of such temperatures. Power Jacks suggest that a lubricant manufacturer be consulted for type of grease and lubrication schedule. As a general rule, the screw jack unit should be shielded to keep ambient temperatures to 90°C or less.
-  5.2.18 **Minimum Temperature For C-Series Screw Jacks**
With the standard lubricant and materials of construction, the screw jacks are suitable for use at sustained temperatures of -20°C. Below -20°C, low temperature lubricant should be used and no shock loads are present. Power Jacks application engineers must be consulted in these instances for a recommendation. Screw Jacks with standard material of construction and lubrication may be safely stored at temperatures as low as -55°C.
- 5.2.19 **Thermal / Heat Build-Up in a Screw Jack as it is operated**
The duty cycle, the length of the screw, the magnitude of the load, and the efficiency of the screw jack all have a direct influence on the amount of heat generated within the screw jack. Long lifts can cause serious overheating. Note that high duty S-Series screw jacks have a higher thermal capacity than conventional worm gear screw jacks.
- 5.2.20 **Screw Jacks to Pivot a Load**
A screw jack can be built to pivot a load by two methods:
- 5.2.20.1 **Double Clevis Screw Jack**
The screw jack can be furnished with a clevis at both ends (commonly referred to as a double clevis screw jack). The bottom clevis is welded to the bottom end of an extra strong cover pipe, which is fitted to the base of the screw jack. This cover pipe still performs its primary function of encasing the lifting screw in its retracted portion.
- 5.2.20.2 **Clevis - Trunnion Mounting**
The screw jack is fitted with the pivot end fitting (e.g. Clevis) on the lead screw and a trunnion mount adapter is bolted to the screw jacks base plate.

The design of the structure in which these types of screw jacks are to be used must be constructed so that screw jack can pivot at both ends. Use only direct compression or tension loads, thereby eliminating side load conditions

5.2.21 Corrosion Resistant Properties

Screw Jacks can be supplied with alternative materials and/or paint specifications for high corrosive areas. These options include stainless steel, chrome plating, Electro-nickel plating, epoxy paint, etc. Check the unit specification is suitable before installation.

5.2.22 Using Screw Jacks within a Rigid Structure or Press

Power Jacks recommend that the screw jack selected has a greater capacity than the rated capacity of the press or of the load capacity of the structure. We also recommend that a torque clutch or similar device be used to prevent overloading of the screw jack unit. Unless these precautions are taken, it is possible to overload the screw jack without realising it.

5.2.23 Screw Jack Drift after Drive Motor is Switched Off

The screw jack will drift after the motor drive is switched off unless a brake of sufficient capacity is used to prevent it. The amount of drift will depend upon the load on the screw jack and the inertia of the rotor in the motor.

For machine screw jacks with no load, the amount of drift will depend upon the size and speed of the motor. For example, a 1500 RPM input directly connected to a screw jack without a load will give on average 35mm to 60mm of drift; a 1000 RPM input will give about 1/2 as much drift. Note that the drift varies as the square of the velocity (RPM). The drift of the screw jacks screw can be controlled by using a magnetic brake on the motor. Variations of drift will also be seen if the motor drives the screw jack via a reduction gearbox.

5.2.24 Screw Jacks Operation where Vibration is Present

Screw Jacks will operate in areas with vibration, however the vibration may cause the lead screw to "creep" or "inch" under load. For applications involving slight vibration, select the higher of the worm gear ratios. If considerable vibration is present, use a motor equipped with a magnetic brake, which will prevent the screw jack from creep and/or back-driving.



5.2.25 Use of Screw Jacks Fitted With Emergency Stop Disc

To prevent over travel of the lead screw a stop disc or nut can be fitted to a screw jack that is hand operated. It should not be used as a full power stop.



5.2.26 Use of Screw Jacks Fitted With Emergency Stop Nut

For motor driven units it is possible for the full capacity of the screw jack or even a greater force (depending on the power of the motor) to be applied against the stop. These stops are called "full power stop nuts". They must only be used as an emergency device and if such a condition occurs an assessment made to discover why it happened in order to carry out preventative action. If the full power stop nut is used at full load in an emergency it might be driven into the unit jamming so tightly that it must be disassembled in order to free it.





It is recommended that external stops are fitted where possible, however they must only be used as a last resort (Note - limit switches are one possible solution to constrain screw jack movement safely - consult Power Jacks for system advice). Under ideal conditions where a slip clutch or torque limiting device is used, a stop pin or stop nut may be used - but Power Jacks should be consulted.

5.2.27 Screw Jack System Arrangements

Perhaps the greatest single advantage of Power Jacks screw jacks is that they can be linked together mechanically, to lift, lower, move or position in unison. Typical mechanical system arrangements link 2, 4, 6 or 8 screw jacks together and are driven by one motor. As an alternative screw jacks can be individually driven by electric motors and with suitable feedback devices such as encoders be synchronised electronically by a control system.

-  5.2.28 **Connecting Screw Jacks in Series**
The number of screw jacks that can be connected in series is limited by input torque requirements on the first worm shaft in the line. For the C-Series the torque on the worm shaft of the first screw jack should not exceed 300% of its rated full load torque (this does not include the 200kN screw jacks which are rated at 200%).
- 5.2.29 **Efficiency of a Multiple Screw Jack System**
In addition to individual device efficiencies, the efficiency of the screw jack arrangement must be taken into consideration. The arrangement efficiency allows for misalignment due to slight deformation of the structure under load, for the losses in couplings, bearings, and for a normal amount of misalignment in positioning the screw jacks and gearboxes. For efficiency values consult Power Jacks product literature or engineers.
- 5.2.30 **Screw Jack Fitted with 3rd Party Accessories**
If your screw jack is fitted with a device not manufactured by Power Jacks then please consult the provided manual for this device.

6.1 General Maintenance Notes

-  6.1.1 Maintenance and replacement work must be done by an expert maintenance technicians trained in the observance of applicable laws on health and safety at work and the special ambient problems attendant on the installation.
-  6.1.2 Before doing any work on the unit, the operator must first switch off power to the screw jacks drive system and ensure that it is out of service, as well as taking all necessary precautions against it being accidentally switched on again or its parts moving without warning.
-  6.1.3 All additional environmental safety precautions must be taken (e.g. elimination of residual gas or dust, etc.).
-  6.1.4 Before doing any maintenance work, activate all safety equipment and, if necessary, inform persons working in the vicinity. In particular, mark off the area around the unit(s) and prevent access to any equipment, which, if activated, might be the cause of unexpected health and safety hazards.
- 6.1.5 Replace worn components with original spare parts only.
- 6.1.6 Use the lubricants (oil and grease) recommended by the Manufacturer.
- 6.1.7 When working on the units, always replace gaskets and seals with new original ones.
- 6.1.8 If a bearing requires replacement, it is good practice to also replace the other bearing supporting the same shaft.
- 6.1.9 Power Jacks recommend replacing the lubricant after all maintenance work where a unit has been dismantled (completely or partially).
- 6.1.10 The above instructions are aimed at ensuring efficient and safe operation of the C-Series screw jack unit.
- 6.1.11 The Manufacturer declines all liability for injury and damage to components due to the use of non-original spare parts and non-routine work, which modifies the safety requirements without the express prior authorisation of the Manufacturer.
- 6.1.12 Refer to the specific spare parts list when ordering spare parts for products.
- 6.1.13 Do not dump polluting liquids, worn parts and maintenance waste into the environment. Dispose of all such materials as stipulated by applicable legislation.

6.2 Regular Maintenance

Also refer to section 6.3

6.2.1 Lubrication Of The Screw Jack

- 6.2.1.1 The screw jacks are shipped packed with grease (unless otherwise called for) which should be sufficient for one month of normal operation.
-  6.2.1.2 **IMPORTANT NOTE** – Lubricant suitability is dependent on duty cycle and ambient temperature. However in general recommended lubricants in section 7 are suitable for operation in an ambient temperature of -10°C to +50°C. If in doubt consult with Power Jacks prior to installation and operation.
- 6.2.1.3 The maintenance engineer should establish a lubrication programme based on the screw jack's duty and use.
- 6.2.1.4 The lead screw requires a light grease film to be applied at Installation. The lead screw should not be over greased.
- 6.2.1.5 Note excessive grease should be avoided.
- 6.2.1.6 It is recommended that the screw jack be fitted with bellows or covers to protect the exposed screw from contamination from dirt and debris.
- 6.2.1.7 If the screw jack or its system is fitted with a brake ensure that under no circumstances lubricant gets into the brake as this can cause brake failure due to loss of friction.

6.2.2 Lubrication Intervals - General

- 6.2.2.1 Regularly check and top up lubrication in the C-Series screw jack(s).



-  6.2.2.2 Refer to section 7 for recommended lubricants.

Item	Operation Type	Lubrication Interval	Grease Type
1	Normal	Check & lubricate as required every 1 month	Extreme Pressure Grease or equivalent. Refer Section 7 Table 1
2	Arduous	Check & lubricate as required every 1 week	Molybdenum disulphide grease or equivalent. Refer Section 7 Table 2

- 6.2.2.3 Rotating screw jacks are not supplied with lubricant on the lead screw as the screw thread is exposed. Before operation suitable grease must be applied to the screw.

6.3 Check Unit Operational Performance

- 6.3.1 Remove dust / dirt / debris deposits from the unit(s).
- 6.3.2 Check that noise at constant load does not vary. Excessive vibration or noise can indicate wear of a gear in a gearbox or failure of a bearing.
- 6.3.3 Check for lubricant leaks from the gaskets/seals, caps and casings.

- 6.3.4 Check all bolted joints/couplings for wear, deformation or corrosion and tighten them down fully without over tightening.
-  6.3.5 A periodic check of backlash between lead screw and worm gear (translating screw jacks) or lead screw and nut (rotating screw jacks) is recommended to check wear on internal threads of worm gear. Backlash in excess of 50 % thread thickness indicates that a replacement will be necessary to replace the worm gear / nut assembly.
- 6.3.6 If driven by an electric motor check the power absorption and voltage against the nominal values given on the motor's nameplate.
-  6.3.7 The gearbox section of the C-Series screw jack operates with a maximum case temperature of 90°C. If this temperature is exceeded Power Jacks should be consulted.

6.4 Repair of Power Jacks C-Series Screw Jacks

-  6.4.1 Power Jacks recommend that a C-Series screw jack is returned to Power Jacks for repair. A full inspection and repair service is available.

6.5 Rebuild Procedure

Power Jacks recommend the following procedures for assembly and disassembly of a C-Series screw jack.

- 6.5.1 Tag critical parts to facilitate reassembly.
- 6.5.2 Place all screws, washers and other small fixing components in a tagged bag/box with the associated product on which they are to be used referenced on the tag.
- 6.5.3 Mark mating surfaces to ensure proper meshing.
- 6.5.4 Clean and lubricate all parts as required.
- 6.5.5 All seals must be replaced when rebuilding.
- 6.5.6 All screws, washers and other small component parts must be replaced if damaged in any way.
- 6.5.7 Replace damaged or "frozen" lubrication fittings with new ones.

6.5.8 General Dis-mantle & Rebuild Procedure

- 6.5.8.1 Remove the lead screw from the screw jack body.
- 6.5.8.2 Unscrew the fasteners fixing the shell cap.
- 6.5.8.3 Unscrew the shell cap and release the thrust bearings and worm gear.
- 6.5.8.4 Remove one circlip and gently tap out the worm shaft from the opposite side with a soft mallet (e.g. rubber mallet).
- 6.5.8.5 Inspect and replace parts for wear or damage.

- 6.5.8.6 When installing the worm shaft, use shims to establish the correct axial float for the bearings Installed.
- 6.5.8.7 When screwing in the shell cap, establish the correct tightening torque by screwing down and backing off the shell cap until the torque figure for the model is achieved.
- 6.5.8.8 Lock the shell cap in place with locking fasteners.
- 6.5.8.9 For fasteners without spring lock washers use a chemical thread locking compound (e.g. Loctite).

6.6 Replacing Parts

- 6.6.1 Do not hesitate to replace parts and/or components if they are not able to guarantee safe and reliable operation.
- 6.6.2 Never improvise repairs.
-  6.6.3 The use of non-original spare parts not only voids the warranty but also can compromise unit operation.

6.7 Required Tools

- 6.7.1 A press, coupling puller, impact extractor and common hand tools.

6.8 Lifting Units

- 6.8.1 When lifting, use accessories such as eyebolts, snap hooks, screw clamps, straps, ropes, hooks etc. which are certified and adequate for the load. Use soft slings around the body of the jack and do not lift by placing slings, chains or hooks around the input drive shafts.
- 6.8.2 The weight of the standard product and additional incremental weight amounts for the actual stroke of the supplied unit are given in this manual in section 3.

6.9 Cleaning

- 6.9.1 External Cleaning
 - 6.9.1.1 Clean all dust and process waste off the unit. Do not use solvents or other products, which are incompatible with the construction material and do not direct high-pressure jets of water at the unit.
- 6.9.2 Internal Cleaning
 - 6.9.2.1 Remove lubricant from unit and do not re-use old lubricants.

6.9.2.2 Flush a unit's interior thoroughly with a light solvent before refilling with new lubricant.

6.9.3 Warning



6.9.3.1 Provide adequate ventilation during the use of cleaning agents; avoid prolonged breathing of fumes and contact with skin.

6.9.3.2 Use clean hot water or a soap solution for general cleaning of painted surfaces.

6.9.3.3 Dry parts thoroughly after cleaning.

6.10 Painting

6.10.1 If a unit is to be painted, tape the nameplate, mounting surfaces and seal rings to prevent contact with solvent prior to painting.

7 Recommended Lubricants

Table 1 - Normal Operation

Manufacturer	Lubricant
Castrol	Spheerol EPL2
Esso	Beacon EP2
Gulf	Gulfcrown EP2
Mobiloil	Mobilux EP2
Power Petroleum	BP Energrease LC2
Regent	Texaco EP2
Shell	Gadus S2V220AC2 (Alvania WR2)

Table 2 - Arduous Operation

Manufacturer	Lubricant
Castrol	Spheerol LMM2
Esso	Beacon EP2 Moly
Mobiloil	Mobilgrease XHP222 Special
Power Petroleum	BP Energrease L2 1M
Regent	Molytex 2
Shell	Shell Greases 5826 (Overseas)
	Shell Alvania HDX2

8.1 Recommendations

8.1.1 C-Series screw jacks are fully supported by Power Jacks. Spare parts and repairs are available.



8.1.2 It is recommended that when a screw jack is used in a production critical environment where the cost of downtime far exceeds the cost of the screw jack a complete spare screw jack unit is stocked by the customer. This allows the worn/damaged unit to be returned to Power Jacks for repair by trained personnel. Alternatively it allows time for a new replacement screw jack to be manufactured.

8.1.3 When enquiring about replacement parts or a complete unit please send the following information to Power Jacks:

- Screw Jack Serial Number (found on product name plate - essential)
- Screw Jack Model Number (found on product name plate - essential)
- Original Purchase Order Number (if known).
- Power Jacks Sales Order Number (if known)
- Your Contact Details (essential)

9.1 General Storage Recommendations

Recommendations for storing the products are indicated below:

- 9.1.1 Store in a clean and dry environment, free from dirt and dust.
- 9.1.2 Screw Jack Storage Temperature: -10°C to +50°C.
- 9.1.3 Do not store the unit in excessively humid conditions or where it is exposed to the weather (do not store outdoors).
- 9.1.4 Do not place product directly on the ground.
- 9.1.5 Store product(s) on a stable base and make sure that it is not subjected to accidental displacement.
- 9.1.6 Store the unit(s) in the packaging provided for shipping (if allowed).
- 9.1.7 If products are to be stored for more than 6 months, the following additional precautions must be taken:
 - 9.1.7.1 Cover all machined external surfaces with a rust-proofing product.
 - 9.1.7.2 Fill the unit with appropriate lubricant if not supplied with lubricant.
- 9.1.8 Ensure that all screw jacks are stored in the fully retracted (closed) position.
- 9.1.9 All rotating parts should be turned by hand a few revolutions per month. If this is not practical, then an external drive should be used to run the unit(s) for a few revolutions.

9.2 Long Term Storage

In the event that a screw jack(s) is to be stored for more than 6 months prior to installation/commissioning, Power Jacks Ltd should be consulted to discuss preservation requirements.

10.1 General Disposal Guidance

- 10.1.1 This must only be done by operators trained in the observance of applicable laws on health and safety at work.
- 10.1.2 Do not dump non-biodegradable products, lubricants and non-ferrous materials (rubber, PVC, resins, etc.) into the environment. Dispose of all such materials as stipulated by applicable environmental protection legislation.
- 10.1.3 Do not attempt to re-use parts or components which appear to be in good condition after they have been checked and/or replaced by qualified personnel and declared unsuitable for use.

11.1 Warranty Definitions

When used in these conditions the following words have the meanings set out opposite them below:

Company:	Power Jacks Limited
Contract:	The contract between the Company and the Customer for the supply of the Goods.
Customer:	The party to whom the Goods are to be supplied under the Contract
Goods:	The goods to be provided under the Contract
Writing:	Includes facsimile or electronic transmission and comparable means of communication

11.2 Warranty Statement

The Company warrants that any Goods sold by it under Power Jacks standard terms and conditions of sale will be free from defects caused by faulty materials or poor workmanship but gives no warranty and makes no representation whatsoever express or implied as to any other matters including without limitation condition merchantability or fitness for any purpose.

The Company shall incur no liability under this warranty unless:

- The Company is promptly notified in Writing upon discovery of any such defects by the Customer and the Customer forthwith ceases to use the defective Goods unless otherwise authorised by the Company; and
- The defective item is immediately returned to the Company, transportation charges being prepaid by the Customer or the Company is, at its option, given the opportunity to remedy any defect.

The Company's warranty as specified above is limited to a period of 12 months from the date of delivery and its liability shall be limited to replacing, repairing or issuing credit at its option for any Goods returned by the Customer within the aforesaid period.

The Company shall not be liable for consequential loss or damage by reason of any defect in (or failure to comply with any written estimate of performance of) Goods supplied by the Company whether original or substituted.

The Customer will indemnify the Company against all third party claims made in respect of the Goods.

12.1 Parts List

Item	Description
Base Model Parts	
1	Shell (Gearbox Housing)
2	Shell Cap
3	Worm Shaft
4	Worm Gear
5	Load Bearing
6	Worm Bearing
7	Retaining Ring (Circlip)
8	Shim kit (if required)
9	Seal (worm shaft)
10	Grease Nipple
11	Set Screw (Shell Cap)
12	Key (Worm Shaft)
13	Name Plate
14	Drive Screw (Name Plate)
15	Copper Plug
Translating Screw Model Parts	
20	Translating Lead Screw – Single Start
21	Translating Lead Screw – Double Start
22	Cover Pipe
23	End Cap (Cover Pipe)
Rotating Screw Model Parts	
30	Rotating Lead Screw – Single Start
31	Rotating Lead Screw – Double Start
32	Nut
33	Drive Key (Lead Screw)
34	Set Screw (Lead Screw – Lock Nut)
35	Lock Nut (Lead Screw)
36	Washer (Lead Screw – Lock Nut)
37	Plug / Cover Pipe
38	Guide Bushing (Plain)
Anti-Backlash Model Parts	
50	Set Screw (Shell Cap – Anti-Backlash)
51	Shell Cap – Anti-Backlash Models
52	Anti-Backlash Nut
53	Anti-Backlash Gear
54	Dowel Pin – Anti-Backlash Models
55	Access Cap

Item	Description
Anti-Rotation (Keyed) Model Parts	
70	Shell Cap – Anti-Rotation Models
71	Lead Screw – Keyed – Single Start
72	Lead Screw – Keyed – Double Start
73	Key (Lead Screw / Shell Cap)
74	Lock Washer (Anti-Rotation Shell Cap)
75	Cap Screw (Anti-Rotation Shell Cap)
76	Guide Bushing
Anti-Rotation (Keyed) & Anti-Backlash Model Parts	
80	Key Adapter
81	Bolt (Key Adapter)
Safety Nut - Rotating Screw Model Parts	
90	Nut
91	Safety Nut
Safety Nut - Translating Screw Model Parts	
100	Set Screw (Shell Cap – Safety Nut Models)
101	Shell Cap – Safety Nut Models
102	Safety Nut - Translating Screw
103	Safety Nut Gear
104	Dowel Pin – Anti-Backlash Models
105	Access Cap
End Fittings	
Item	Description
200	Top Plate
201	Clevis End
202	Fork End
203	Rod End
204	Set Screw (End Fixture) – 2 off at 180 degrees
Accessories	
300	Bellows Boot kit (Includes 2 “Jubilee” clips)

Notes:

Not all parts are required for each screw jack, refer to general arrangement drawing corresponding with the model of screw jack.

12 General Assembly & Parts List

12.2 Rotating

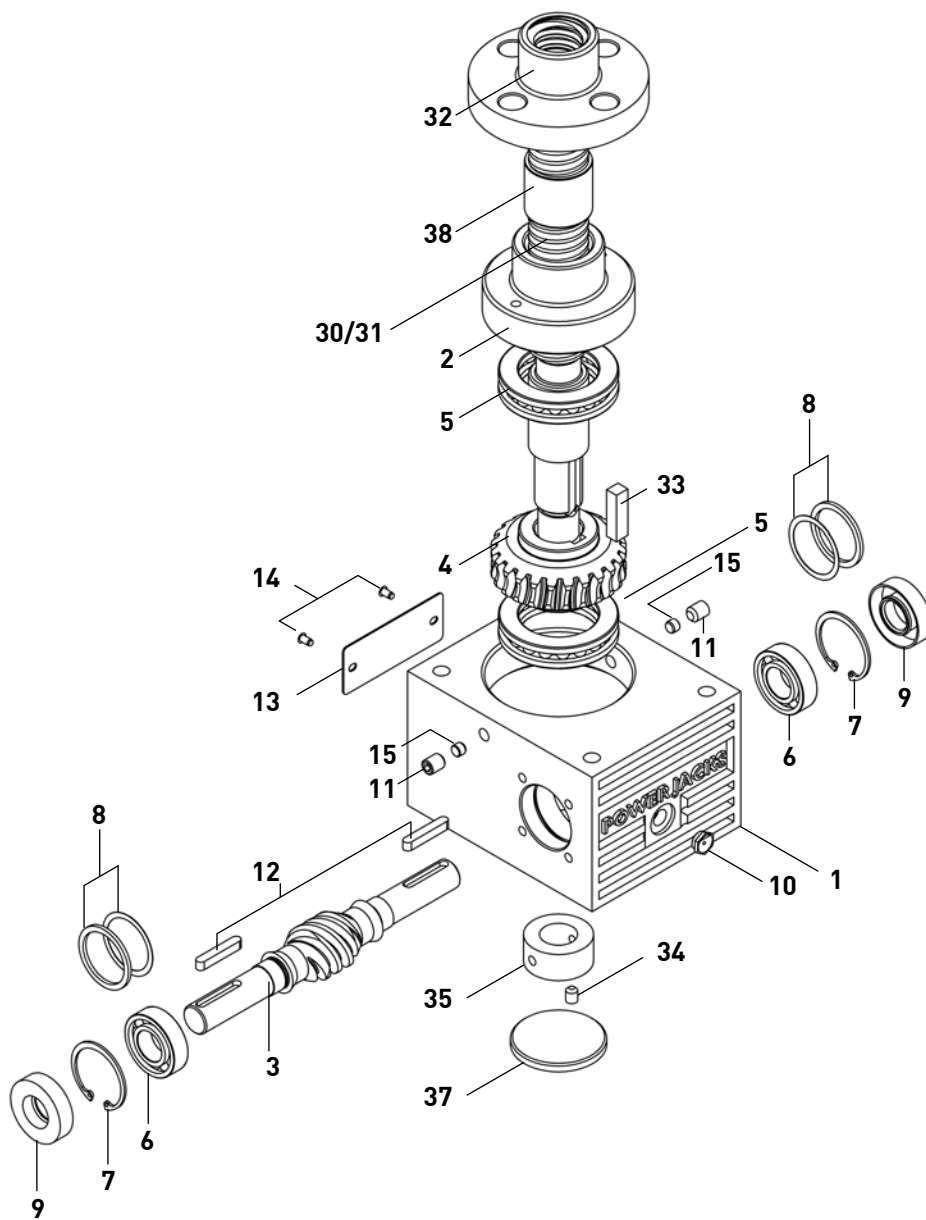

12.3 Translating

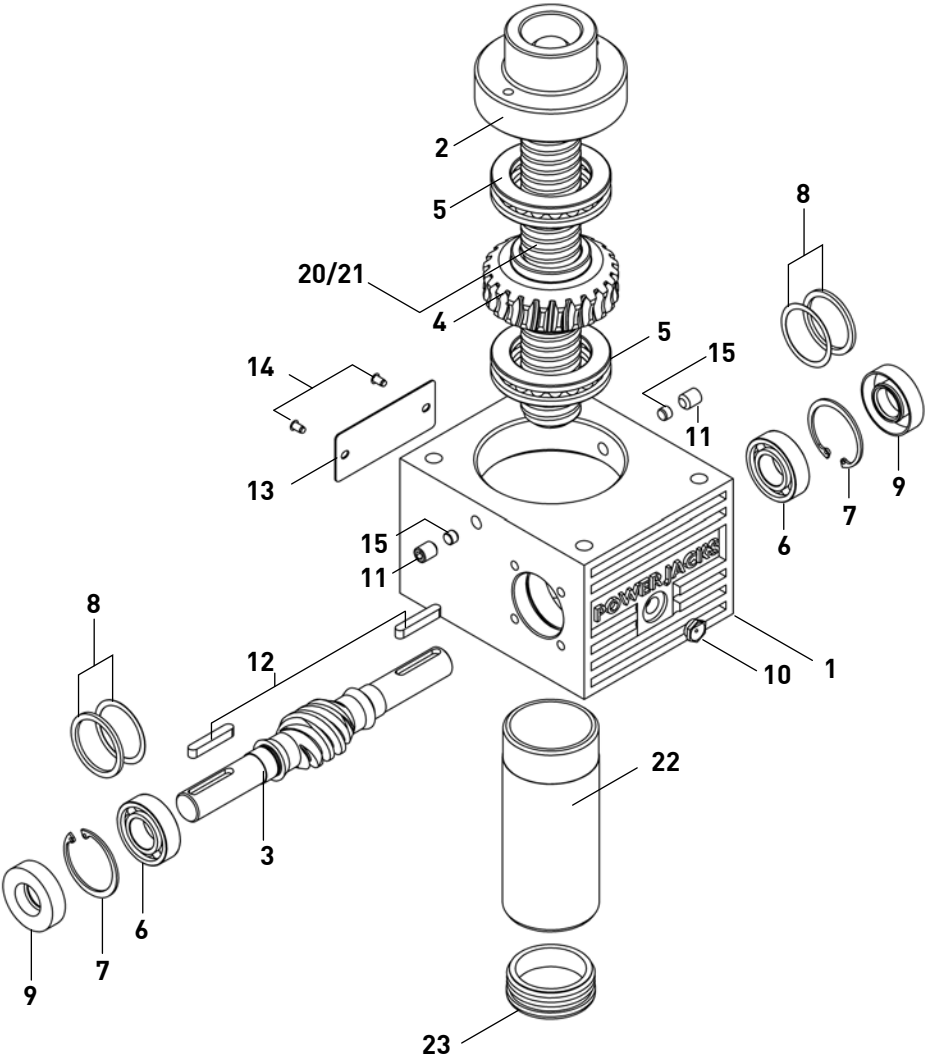

12 General Assembly & Parts List

12.4 Translating Anti-Backlash

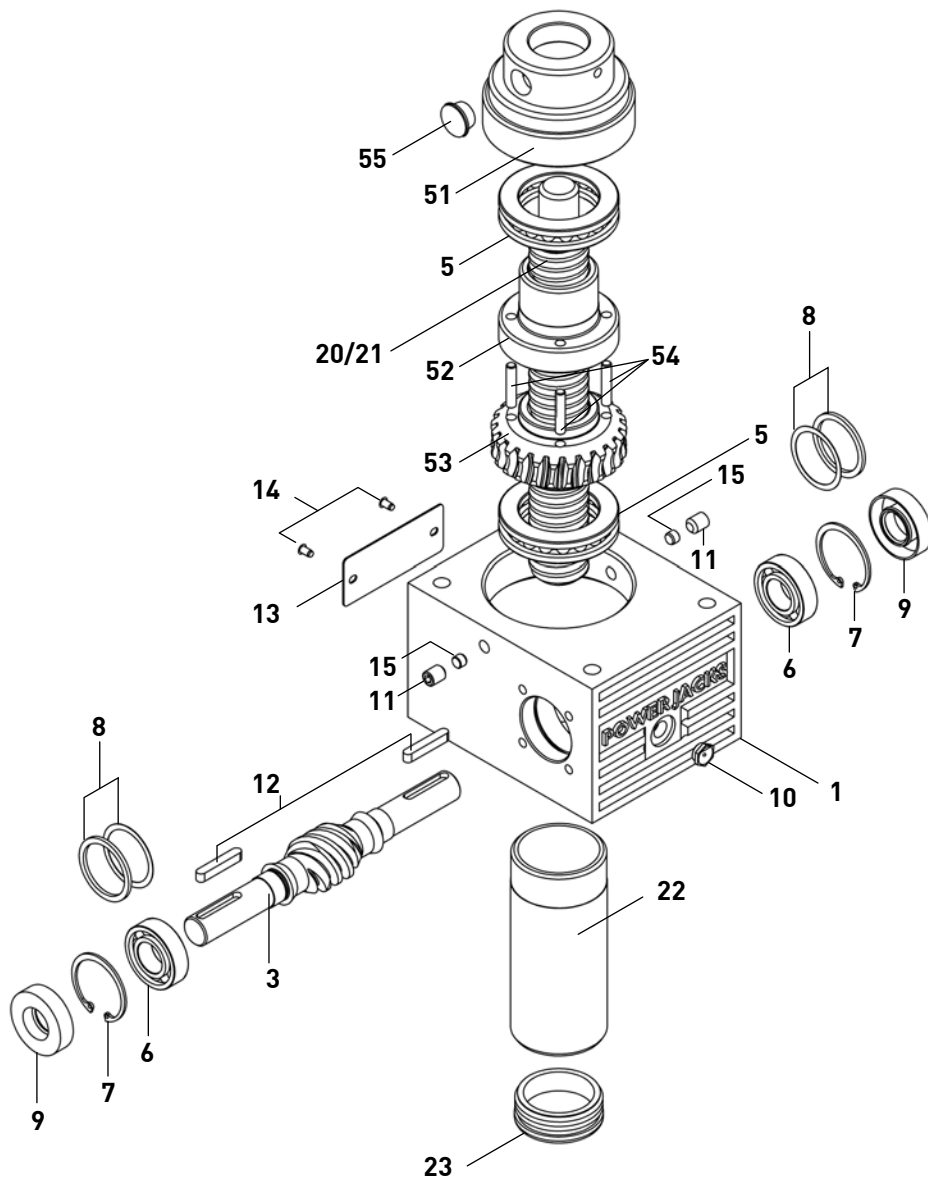

12.5 Translating Anti-Rotation (Keyed)

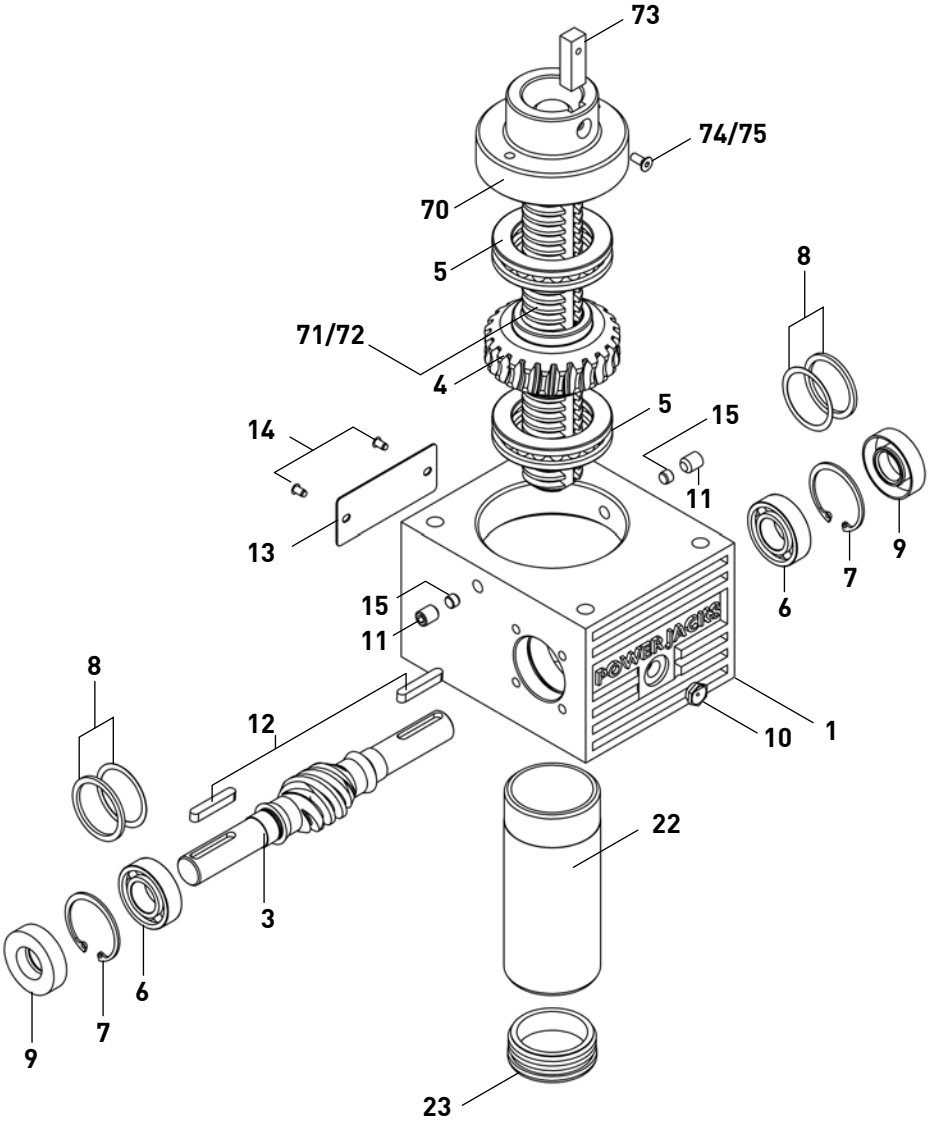

12.6 Translating Anti-Backlash & Anti-Rotation (Keyed)

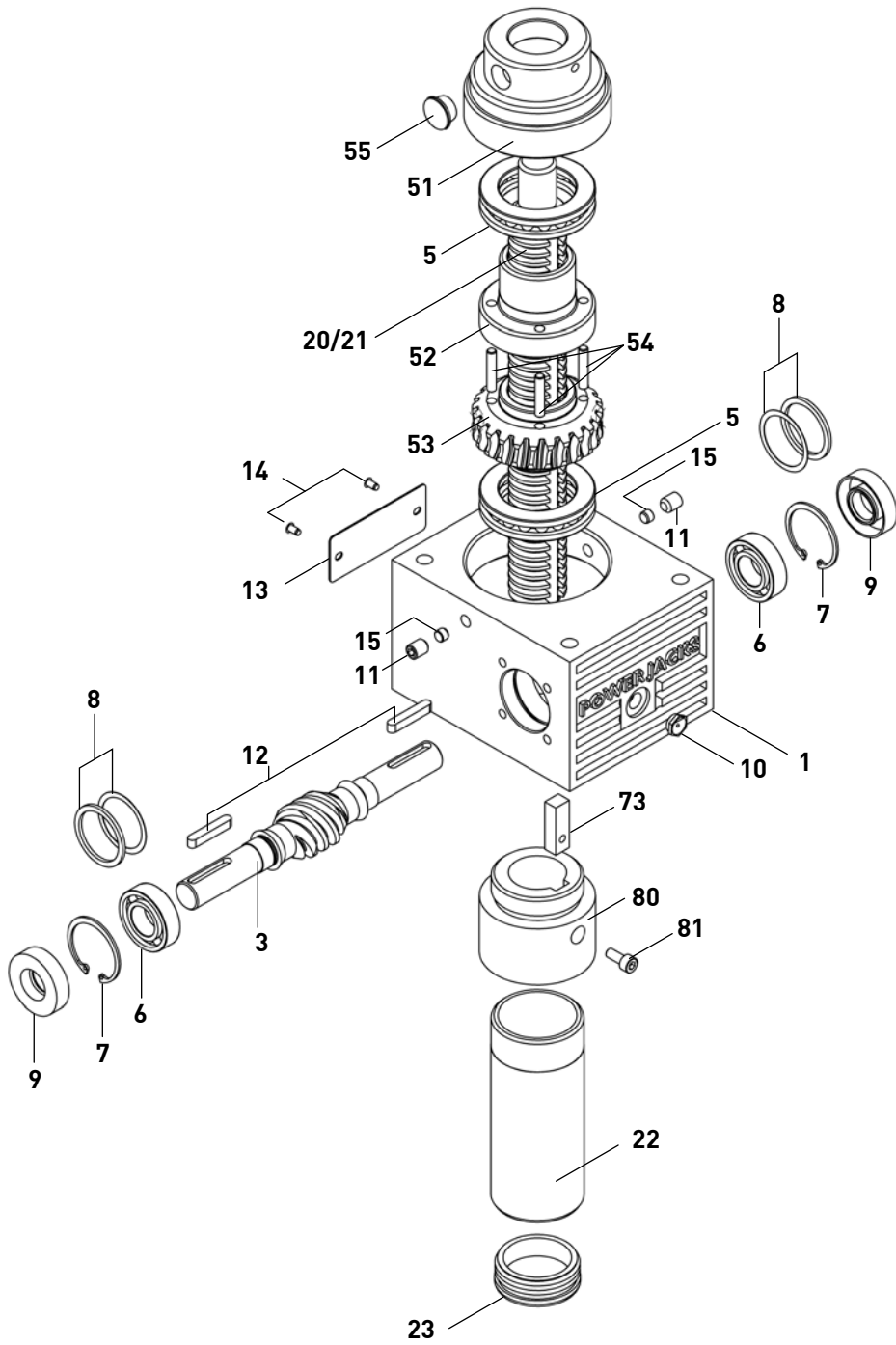

12.7 Accessories & Options



Anti-Backlash

Anti-Rotation (Keyed)

Safety Nut

Trunnion Mounts

End Fittings

Limit Switches

Motor Adaptors

Corrosion Protection

Rotary Limit Switch Adaptor

Double Hub Nut

Drives

Secondary Guide



Lifting & Positioning Solutions

Power Jacks are specialist industrial engineers providing design, manufacturing and services of quality industrial lifting, positioning and load monitoring equipment.

Our products are supplied globally across many sectors including Industrial Automation, Energy, Transport, Defence and Civil.

Power Jacks Ltd
Balmacassie Commercial Park
Ellon, AB41 8BX
Scotland (UK)
Tel: +44 (0)1358 285100

www.powerjacks.com
sales@powerjacks.com

[Sign up for News and Updates](#)

MM-SJCMS-EN-01



All information in this document is subject to change without notice. All rights reserved by Power Jacks Limited. May not be copied in whole or in part. ©Power Jacks Limited 2014, Aberdeenshire, Scotland, United Kingdom.

