

Leistung



Serie 38		
Drehmomente (Nm)	Nenn Drehmoment #1	328
	Max. Betriebsdrehmoment #2	505
	Max. Anlaufdrehmoment	758
Eingangsdrehzahl	Max. Drehzahl (U/min)	3000
Thermischer Grenzwert	Leistung (kW)	20,5
Spiel	Winkelminuten	9 bis 16
Wirkungsgrad	(%)	95% - 98%
Standzeit	(Stunden)	>10000
Gehäusematerial		Sphäroguss
Ölmenge	Liter	0,75
	Pints	1,32
Gewicht (kg)	2-Wege - 1:1 & 1,5:1	20
	2-Wege - 2:1 +	23
	3-Wege - 1:1 & 1,5:1	20,5
	3-Wege - 2:1 +	23,5

Hinweise:

#1 Nenn Drehmomente bei einer Betriebsgeschwindigkeit von 1500 U/min

#2 Maximales Betriebsdrehmoment bei einer Geschwindigkeit von 10 U/min Für detaillierte Leistungen für jede Einheit siehe Seite 12 & 13

Zubehör & Optionen

	Motorflansch		Spezielles Übersetzungsverhältnis
	Verlängerte Antriebswelle		Endschalter
	Antriebe		Leichtes Design
	Verstärkte Welle ODER hohes Drehmoment		Entlüftungsrohr
	90°-Entlüftungsrohr		Montagefüße
	Wellenabdeckung		Edelstahl
	Tauchfest		Korrosionsschutz
	Für den Nuklearbereich geeignet		Für den Lebensmittelbereich geeignet
	Niedrige Temperatur		Hohe Temperatur

2-Wege-Hohlwelle

N380H20-10

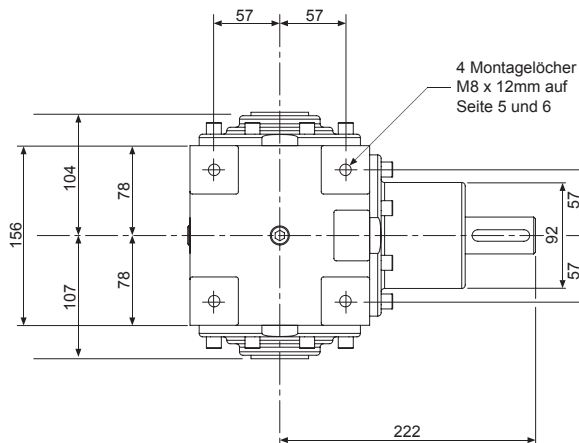
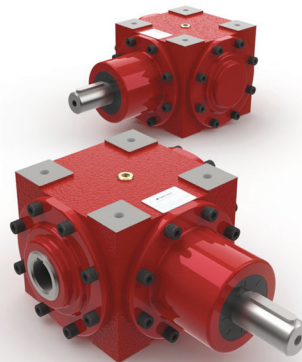

Bohrung mit Gewinde M6 x 16 mm in jedem Ende einer Vollwelle.

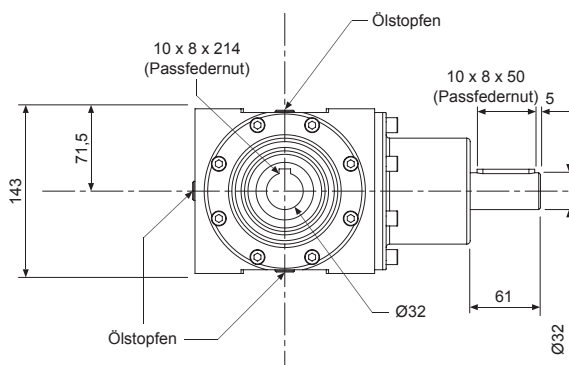

Hinweise:

1. Alle Abmessungen in mm sofern nicht anders angegeben
2. Abmessungen können sich ohne vorherige Ankündigung ändern