

Upright EMT0100-U00

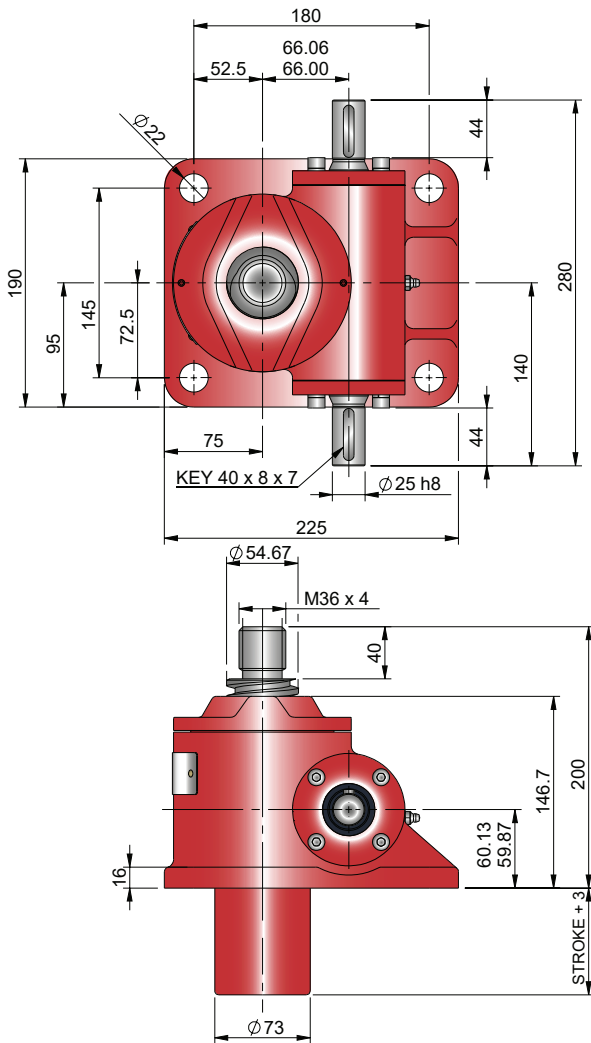

Inverted EMT0100-I00

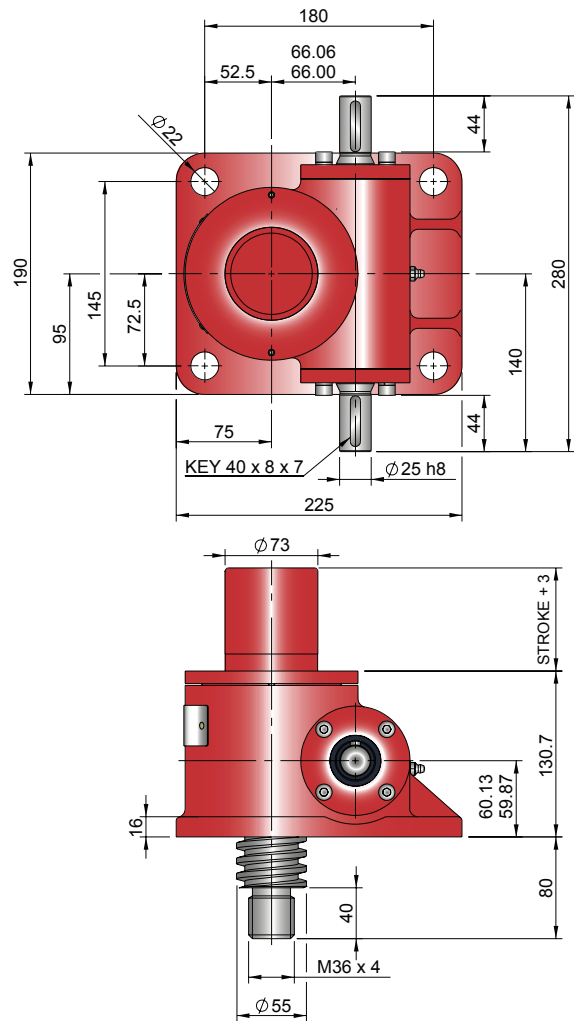

Performance

Model		EMT0100 EMR0100	
Capacity	kN	100	
Lifting Screw	Diameter (mm)	55	
	Lead	Option 1	Option 2
	mm	12	24
Gear Ratio Option 1	Gear Ratio	8:1	
	Static Efficiency	0.206	0.305
	Dynamic Efficiency	0.272	0.388
Gear Ratio Option 2	Gear Ratio	24:1	
	Static Efficiency	0.132	0.195
	Dynamic Efficiency	0.190	0.271
Max. Input power (kW)	Gear Ratio Option 1	3.75	
	Gear Ratio Option 2	1.125	
Start up torque at full load (Nm)	Gear Ratio Option 1	115.9	156.5
	Gear Ratio Option 2	60.5	81.8

Closed Height

Model		EMT0100 EMR0100		
Capacity	kN	100		
Lifting Screw (mm)		12	24	
Turn of worm for travel of lifting screw	Gear Ratio 1	1 Turn	1.5mm	3mm
	Gear Ratio 2	4 Turn	2mm	4mm
Maximum Through Torque (Nm)		347		
Lifting Screw Restraining Torque (Nm)		575	780	
Worm Shaft Maximum Radial Load (N)		1000		
Maximum Input Speed (rpm)		1800		
Gear Case Material		SG Iron		
Weight (kg) - stroke = 150mm		EMT	24.3	
		EMR	28.8	
Weight (kg) - per extra 25mm stroke		EMT	0.58	
		EMR	0.36	

Note: All dimension in millimetres unless otherwise stated.  
Designs subject to change without notice

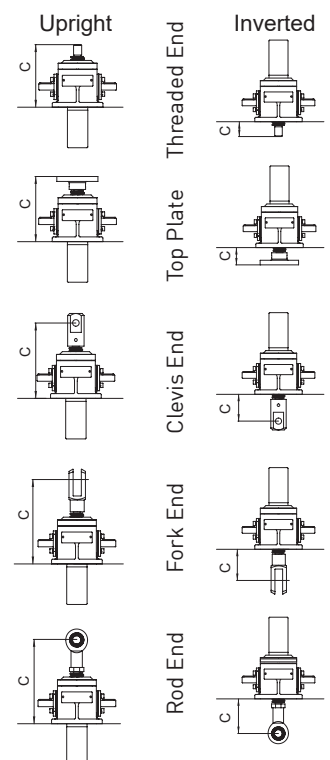

## Upright EMR0100-U00

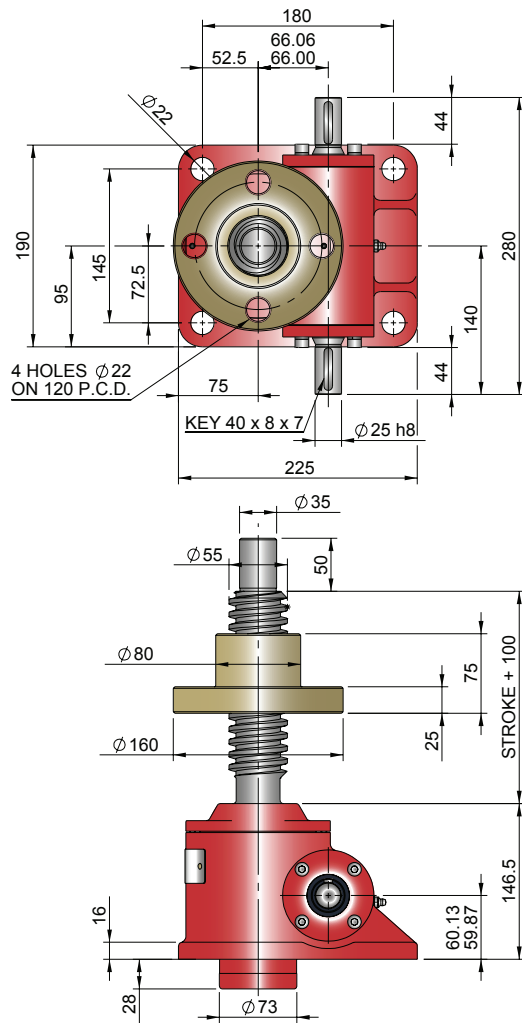

## Inverted EMR0100-I00

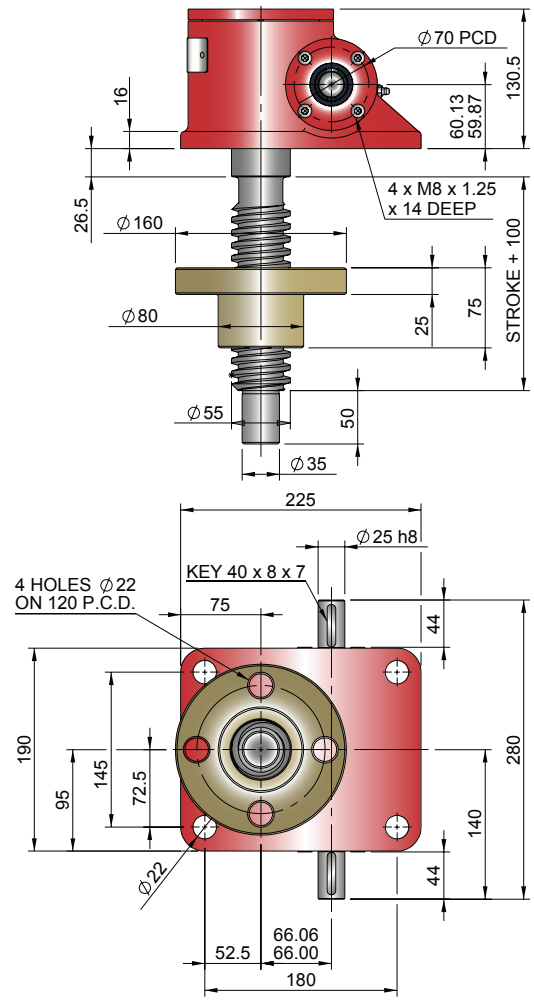

## Closed Height & Bellows Boots

Closed Height "C"	Threaded End		Top Plate		Clevis End		Fork End		Rod End	
	Upright	Inverted	Upright	Inverted	Upright	Inverted	Upright	Inverted	Upright	Inverted
EMT0100	200	80	200	80	245	125	302	182	283	163
Stroke (mm)	EMT0100 with Bellows Boots									
1-300	200	105	200	105	245	150	302	207	298	203
301-600	200	130	200	130	245	175	302	232	298	228
601-1050	225	130	225	130	270	175	327	232	323	228
1051-1500	250	155	250	155	295	200	352	257	348	253

Model	A	B	D	E	G
EMT0100	65	136	15	31	150

Stroke	1-300	301-600	601-1050	1051-1500
EMT0100	20	30	50	70

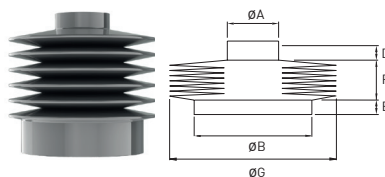

## Column Strength

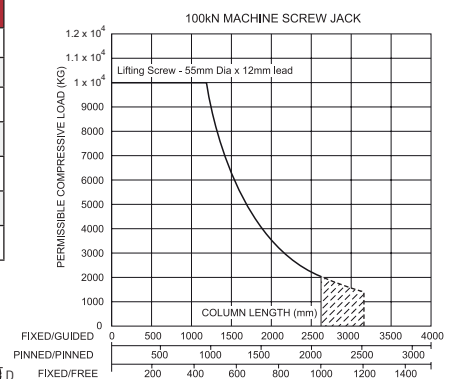

Note:

- 1 Inverted Screw Jacks - Bellows Boot Closed Height assumes screw jack mounted on a structure with thickness = 15mm
- 2 Inverted Screw Jacks - Recommended bellows boot mounting plate  $\varnothing B \times [E + 5\text{mm}]$  thick.
- 3 Inverted Screw Jacks - Screw Jack mounting plate & bellows boot mounting plate are customers own supply
- 4 † Control tapes fitted (increase outer diameter by 20mm approximately).
- 5 For horizontal installations with than 450 mm of stroke, internal boot guides are recommended.
- 6 Customers with threaded end screw jacks must provide a fixing for the unattached bellows boot collar.
- 7 Bellows boots for Rotating Screw Jacks, other sizes, stroke and materials please consult Power Jacks.

