

M-Series Screw Jacks

Inch Machine Screw Jack

Inch Stainless Steel Machine Screw Jack

Inch Ball Screw Jack

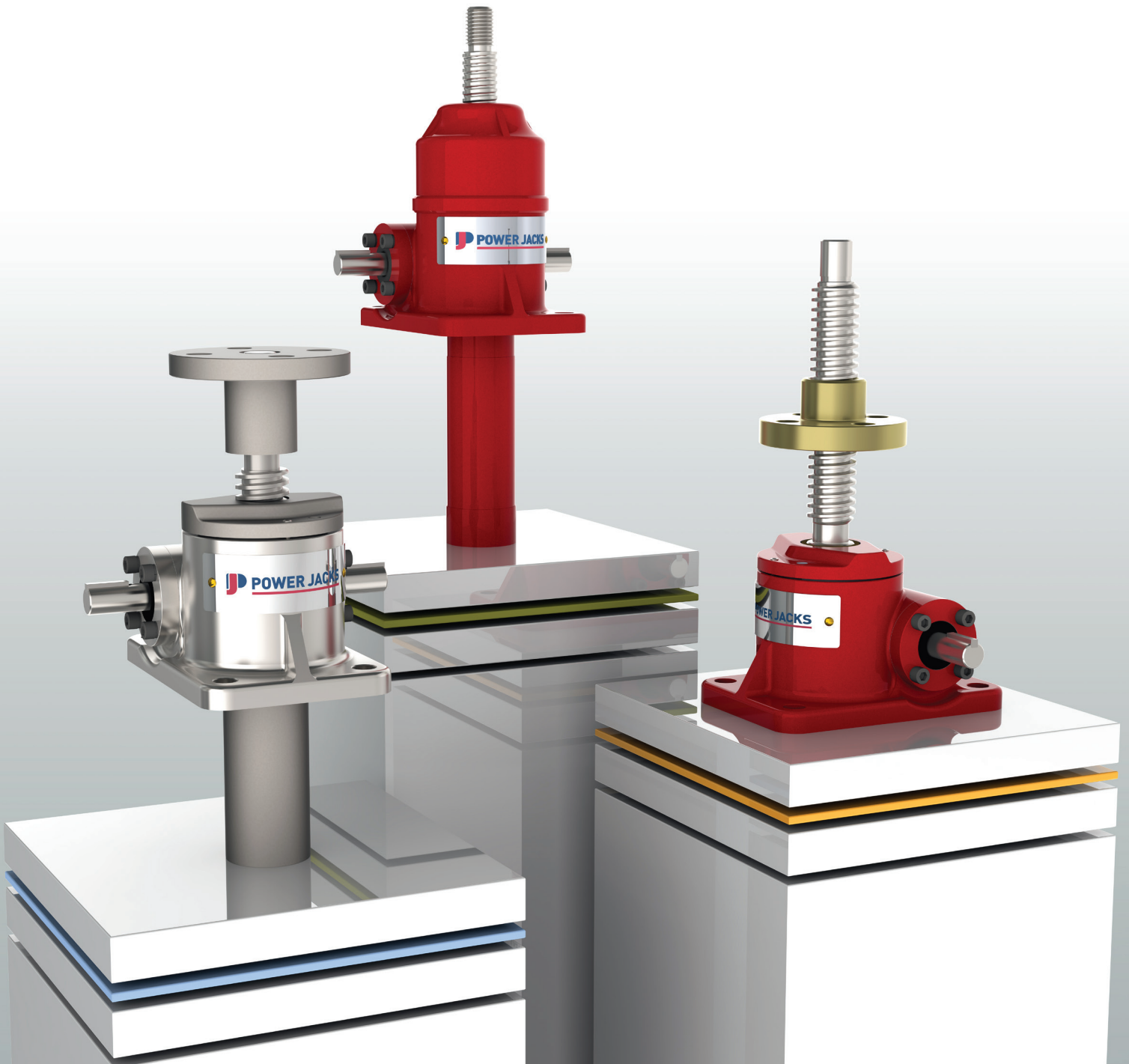

Advantages

- Positive, Mechanical Positioning
- Uniform, Lifting Speed
- Multiple Arrangements
- Anti-Backlash Feature (optional)

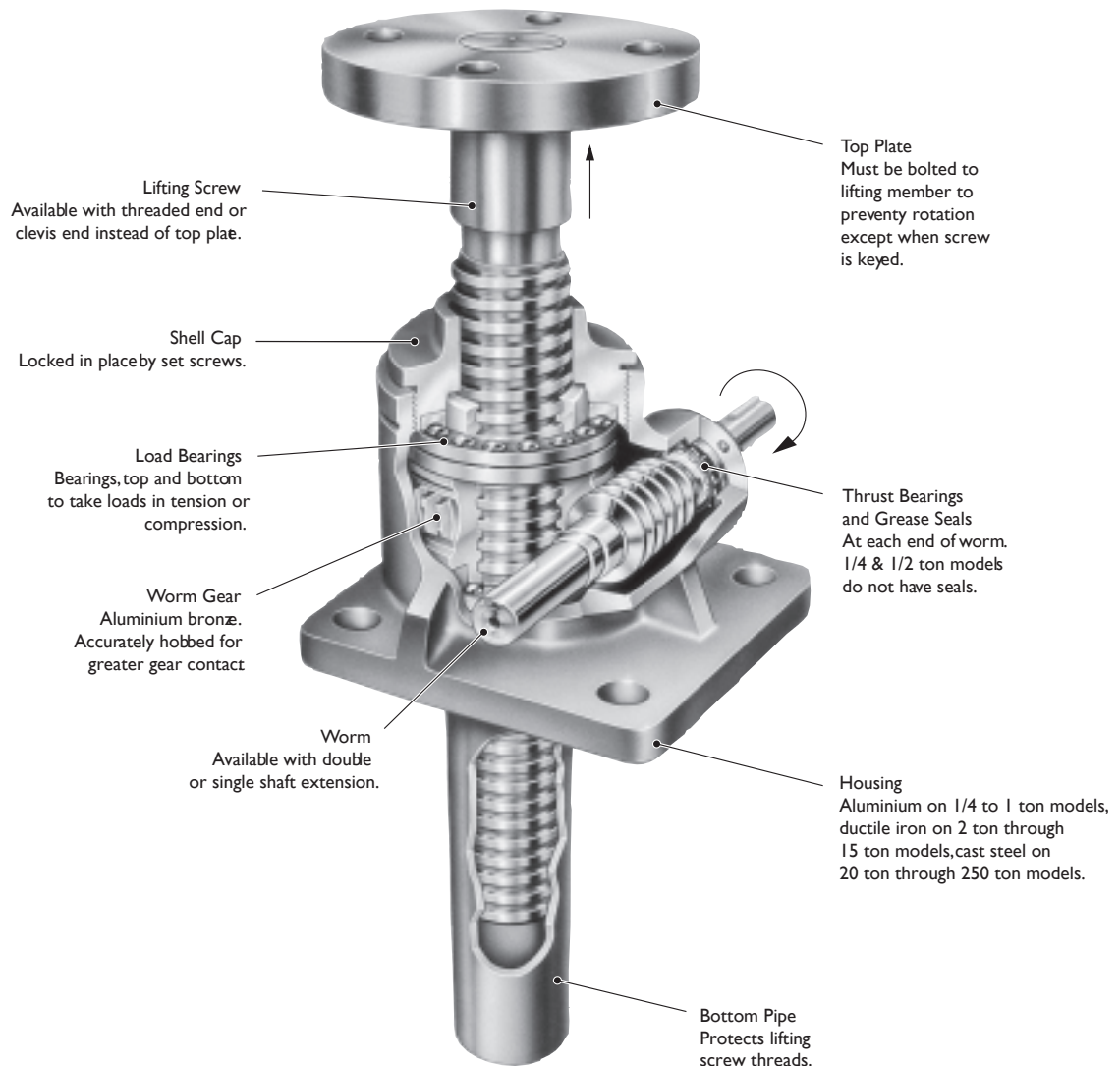

Capacities from 1/4 Ton to 250 Ton
Worm Gear Ratios from 5:1 to 50:1

The imperial machine screw jack range is produced in many standard models with a wide range of capabilities, there is a standard model for almost any requirement.

Operated manually or by motor units imperial jack models can be used singly, in tandem or in multiple arrangements. Since most capacities have a uniform lifting speed, added economy can be realised in raising unevenly distributed loads by operating the different capacities in unison.

Most imperial machine screw jack models with higher ratios are self-locking and will hold heavy loads in position indefinitely without creep, in ideal conditions. However if self-locking is critical, a brake motor or other restraining device should be considered. They can be used to push, pull, apply pressure and as linear actuators. They are furnished with standard raises in increments of 1 inch. Depending upon size and type of load, models are available with raises up to 25 feet.

Features

- **Precise Positioning** - Can be controlled accurately for positioning within thousandths of a millimetre
- **Self-Locking** - Will normally hold loads in position without creeping when using the higher ratio units, as long as the screw jack unit is not subject to vibration. If self-locking is critical a brake motor or other restraining device should be considered.
- **Uniform Lifting Speed** - Since many models have the same gear ratios, various capacities can be used in the same application to lift unevenly distributed loads with uniform speed.
- **Quick, Sure Operation** - Designed and built to be positive acting, for accurate response to motive power.

Options

- **Anti-Backlash Option** - Reduces vertical backlash between the screw and the worm gear nut to a practical minimum for smooth, precise operation and minimum wear.
- **Keyed Option** - Stops a translating screw from rotating when the screw ends are free.
- **Bellows Boot Option** - Protects the screw from dust, dirt, moisture and corrosive contaminants.
- **Double Clevis End Option** - Incorporates a special clevis end bottom pipe and a standard clevis end on the lifting screw

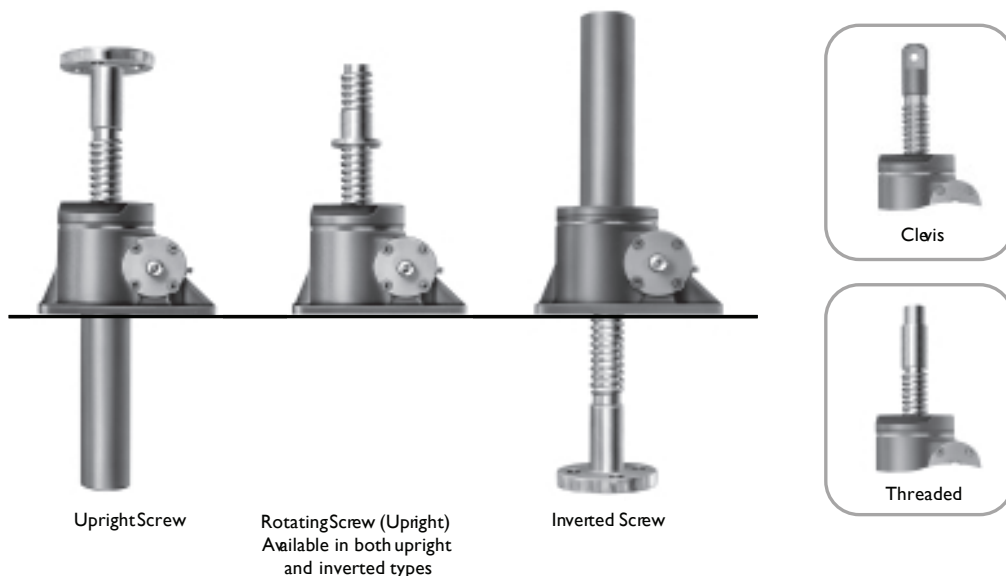

- Note** Clockwise rotation of worm raises load on all models (refer to previous page) - counter clockwise available at extra charge
Unless a translating lifting screw is keyed, the top should be bolted to the lifting member to prevent the screw from rotating.
Screw jacks are equipped with "Alemite" grease fittings.
Recommended lubricants are listed in the installation and maintenance instructions.
Screw jacks supplied complete with drive shaft keys.

Attachments

Nema C-Face flanges, motors, gear boxes, reducers and couplings available for single screw jack drive or multiple screw jack arrangements

Motion control components include motor drives, Motion Controllers with operator interfaces, encoders, limit switches, potentiometers and meters with LCD display

Note: For loads from 25% to 100% of screw jack capacity, torque requirements are approximately proportional to the load.

Raises, measured in increments of one inch, are available up to 20 feet, depending on lifting screw diameter and available bar stock length.

Model	Upright	M2555	M2625	M2501	M1802 & M9002	M1805	M1810	M1815	M1820	M1825	M9035	M1850	M9075	M1899	M18150	M2250
	Inverted	M2554	M2624	M2500	M1801 & M9001	M1804	M1809	M1814	M1819	M1824	M9034	M1849	M9074	M1898	M18149	M2249
Capacity (Short Tons)		0.25	0.5	1	2	5	10	15	20	25	35	50	75	100	150	250
Lifting Screw	Diameter	0.5	0.625	0.75	1	1.5	2	2.25	2.5	3.375	3.75	4.5	5	6	7	9
	Pitch	0.25	0.125	0.2	0.25	0.375	0.5	0.5	0.5	0.666	0.666	0.666	0.666	0.75	1	1
	Form	Acme	Acme	Acme	Acme	Square	Square	Square	Square	Square	Acme	Square	Square	Square	Square	Square
Worm Gear Ratios	Standard	5:1	5:1	5:1	6:1	6:1	8:1	8:1	8:1	10 2 3:1	10 2 3:1	10 2 3:1	10 2 3:1	12:1	12:1	50:1
	Optional	-	-	20:1	24:1	24:1	24:1	24:1	24:1	32:1	32:1	32:1	32:1	36:1	36:1	-
Turns of Worm for 1" Raise	Standard	20	40	25	24	16	16	16	16	16	16	16	16	16	12	50
	Optional	-	-	100	96	64	48	48	48	48	48	48	48	48	36	-
Max. HP per Screw Jack	Standard	0.333	0.333	0.5	2	4	5	5	5	8	8	15	15	25	25	35
	Optional	-	-	0.25	0.5	0.75	1.5	1.5	1.5	2.5	2.5	6	6	11	11	-
Start-Up Torque at Full Load (in.lb)	Standard	13	21	55	120	450	950	1430	2050	3360	4000	7500	12000	16000	28100	20000
	Optional	-	-	25	50	185	490	820	1170	1900	2400	4200	6600	8600	15500	-
Screw Jack Efficiency	Standard	0.330	0.200	0.245	0.232	0.221	0.220	0.202	0.188	0.164	0.158	0.138	0.124	0.130	0.141	0.080
	Optional	-	-	0.140	0.133	0.121	0.140	0.129	0.120	0.092	0.089	0.083	0.075	0.080	0.086	-
Weight with Base Raise of 6" (lb)		2.33	2.33	5	17	35	52	66	93	181	240	410	650	1200	1350	2700
Weight for each Additional 1" Raise (lb)		0.1	0.1	0.27	0.33	0.85	1.4	1.5	2.6	3.5	3.7	5.5	6.5	9	12.6	23

Inch Screw Jacks with Numeric Controls Ratios

1 to 25 Ton screw jacks with Decimal Ratio at no extra cost.

Numeric Control Ratios → 100 Turns = 1" of Travel

Model	Upright	M2501	M1802 & M9002	M1805	M1810	M1815	M1820	M1825
	Inverted	M2500	M1801 & M9001	M1804	M1809	M1814	M1819	M1824
Capacity (Short Tons)		1	2	5	10	15	20	25
Lifting Screw	Diameter	0.75	1	1.5	2	2.25	2.5	3
	Pitch	0.200	0.250	0.250	0.250	0.250	0.250	0.320
	Form	Acme	Acme	Acme	Acme	Acme	Acme	Acme
Worm Gear Ratios		20:1	25:1	25:1	25:1	25:1	25:1	32:1
Turns of Worm for 1" Raise		100	100	100	100	100	100	100
Start-Up Torque at Full Load (in.lb)		24	48	175	370	640	925	1500
Screw Jack Efficiency		0.133	0.132	0.091	0.086	0.075	0.069	0.053
Maximum HP per Screw Jack		0.25	0.5	0.75	1.5	1.5	1.5	2.5

- Note:
1. All other data for these models is the same as main performance table at the top of the page.
 2. For loads from 25% to 100% of screw jack capacity, torque requirements are approximately proportional to the load.



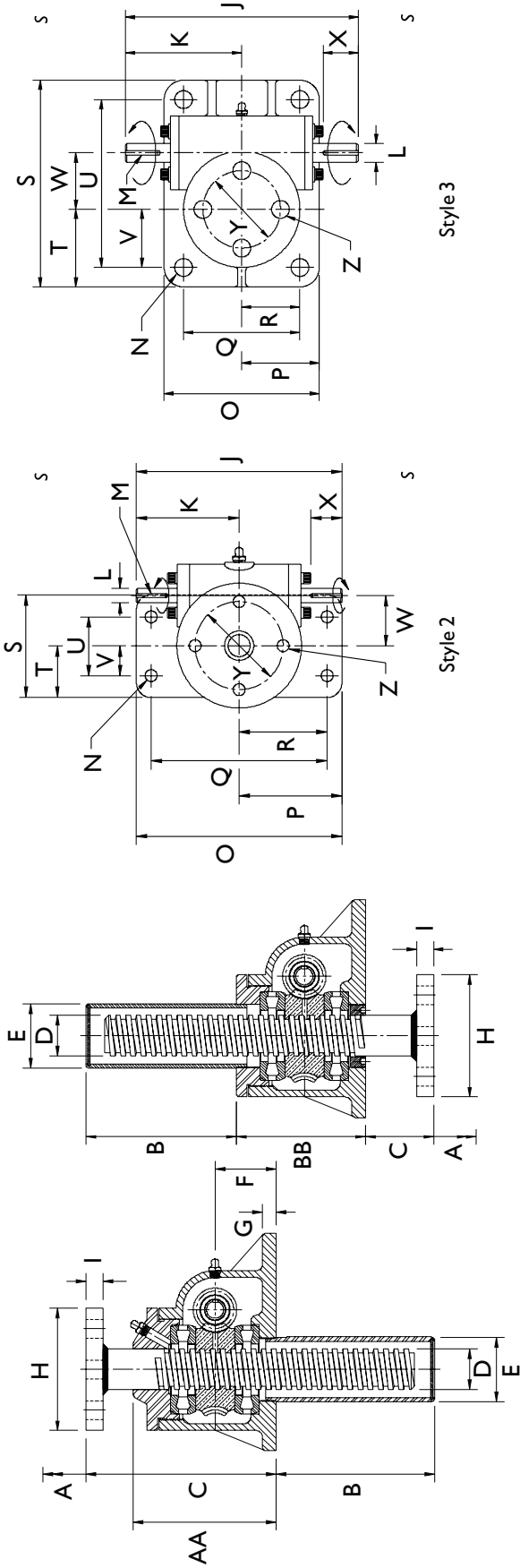

Upright

Inverted

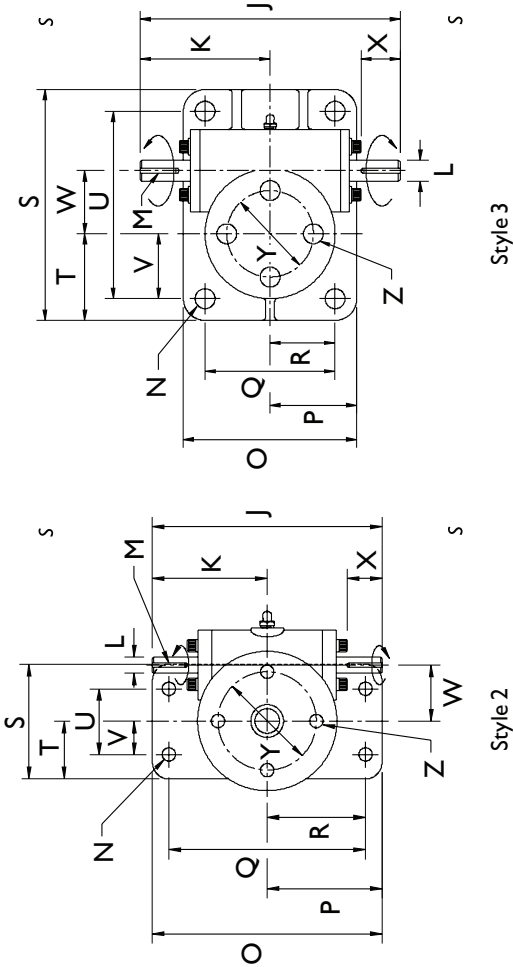

Style 2

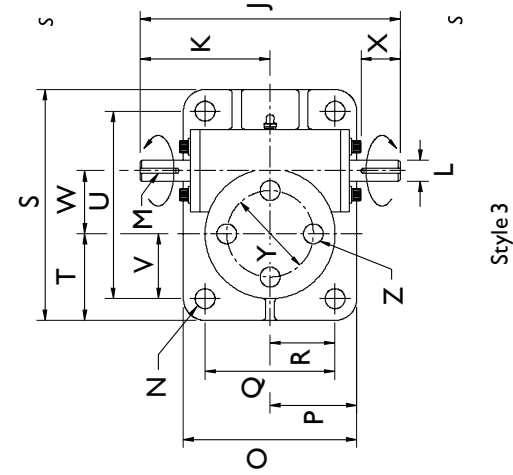

Style 3

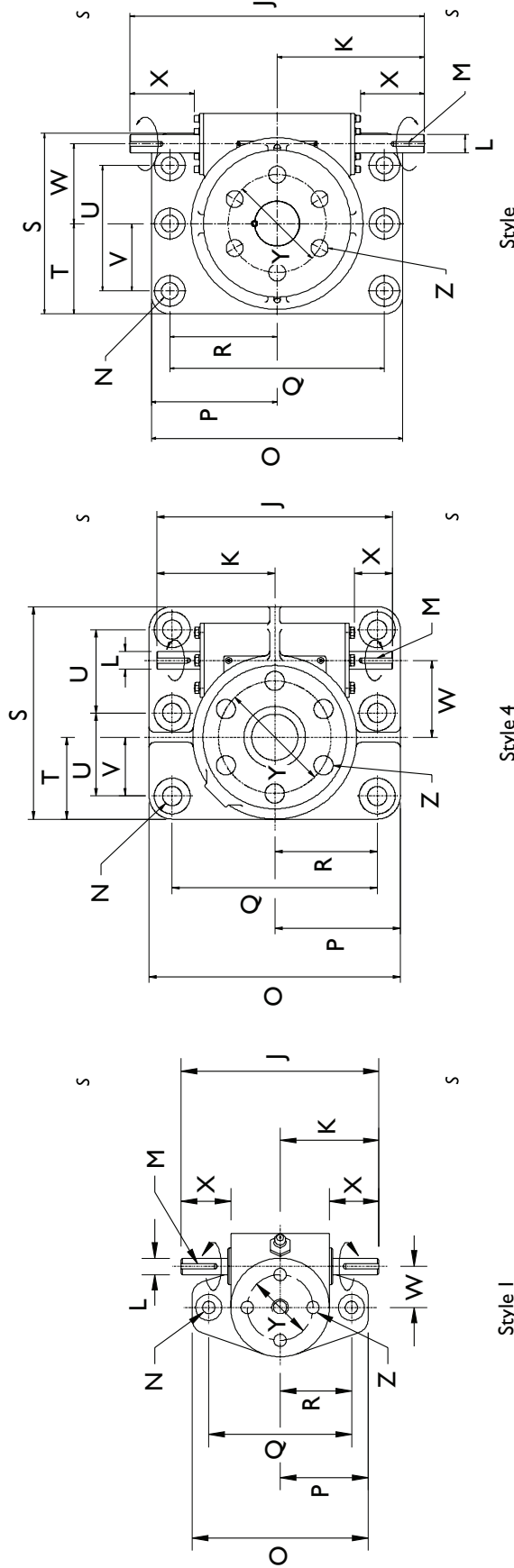

Style 1

Style 4

Style 4

- Note
1. All dimensions in inches
 2. Dimension subject to change without notice

3. LHS = Left Hand Side
4. RHS = Right Hand Side

Model	Upright		M2501	M1802	M9002	M1805	M1810	M1814	M1815	M1820	M1824	M9034	M1850	M9074	M1898	M18150	M2250
	Inverted	Capacity (Short Tons)															
Capacity (Short Tons)			1	2	2	5	10	15	3	3	25	35	50	75	100	150	250
Style			1	2	3	3	3	3	3	3	3	3	2	2	4	4	5
A	AS REQUIRED																
B	Upright	A	A	A-1/8	A-1/4	A-1/8	A-1/8	A-1/8	A-1/8	A-1/2	A	A	A-3/8	A-1/2	A+-1/4	A-1/2	A-2
	Inverted	A	A	A-1/8	A	A-1/8	A-1/8	A-1/8	A-1/8	A-1/2	A	A-1	A-3/8	A-1/2	A+-1/4	A-1/2	A+1/2
C	Upright	4	4.5	5.25	5.25	7	7.25	8	9.25	11	12	12	13	16.5	24	24	30
	Inverted	2	1.25	1.75	1.75	2.5	2.75	2.75	3	3	4	4	3.5	5.5	12	12	12
D	DIA	0.5	0.625	0.75	1	1.5	2	2.25	2.5	3.375	3.75	4.5	5	5	6	7	9
E	Diameter	7/8	7/8	121/32	121/32	23/8	27/8	27/8	31/2	41/2	41/2	59/16	65/8	65/8	7	8	11
F		1	1	1.5	1.75	2.25	2.25	2.75	3.25	4	4	4.75	5.5	5.5	6	6	9
G		5/16	5/16	3/8	1/2	1/2	1/2	5/8	3/4	1	11/4	11/4	13/8	13/8	11/2	11/2	21/2
H	DIA	21/4	21/4	31/2	41/4	41/2	53/4	53/4	53/4	81/2	101/2	111/4	111/4	111/4	14	14	24
I		5/16	5/16	3/8	7/16	5/8	3/4	3/4	3/4	1	15/16	11/4	13/8	13/8	215/16	215/16	315/16
J		41/2	41/2	6	7	9	11	11	11	14	14	14	22	24	23	23	48
K		21/4	21/4	3	3.5	4.5	5.5	5.5	5.5	7	7	7	11	12	11.5	11.5	24
L	DIA	0.375	0.375	0.500	0.500	0.75	1	1	1	1.375	1.375	1.375	1.5	1.75	1.75	1.875	3
		+0.000	+0.000	+0.000	+0.000	+0.000	+0.000	+0.000	+0.000	+0.000	+0.000	+0.000	+0.000	+0.000	+0.000	+0.000	+0.000
		-0.002	-0.002	-0.002	-0.002	-0.002	-0.002	-0.002	-0.002	-0.002	-0.002	-0.002	-0.002	-0.002	-0.002	-0.002	-0.002
M		1/8 x 1/16	1/8 x 1/16	1/8 x 1/16	3/16 x 3/32	1/4 x 1/8	1/4 x 1/8	1/4 x 1/8	1/4 x 1/8	5/16 x 5/32	0.313 x 0.156	3/8 x 3/16	3/8 x 3/16	3/8 x 3/16	1/2 x 1/4	1/2 x 1/4	3/4 x 3/8
		3/4 LING	3/4 LING	1 LING	1 LING	1 LING	1 LING	1 LING	1 LING	2 LING	2 LING	2 LING	2 LING	2 LING	3 LING	3 LING	5 LING
N	DIA	9/32	9/32	13/32	13/32	11/16	13/16	13/16	13/16	11/8	13/8	15/8	17/8	21/8	17/8	17/8	23/4
O		4	4	5	7	6	7.5	73/4	81/4	101/4	10.25	193/4	14	14	241/2	24.5	41
P		2	2	21/2	3.5	3	33/4	37/8	41/8	51/8	51/8	97/8	7	7	121/4	121/4	201/2
Q		31/4	31/4	4	6	31/8	41/2	53/4	6	71/2	71/2	16	10	10	20	20	35
R		15/8	15/8	2	3	19/16	21/4	27/8	3	33/4	33/4	8	5	5	10	10	17.5
S		-	-	-	31/2	8	83/4	91/4	11	133/4	151/2	93/4	23	23	203/4	203/4	291/2
T		-	-	-	13/4	3	27/8	33/8	41/8	51/8	6	47/8	9.5	9.5	8	8	14.75
U		-	-	-	2	61/2	7	71/2	83/4	11	12.5	6	6	19	81/8	81/8	201/2
V		-	-	-	1	1.93	2.25	2.5	3	3.75	4.5	3	3	7.5	5.75	5.75	11
W		0.938	0.938	1.25	1.703	2.188	2.598	2.598	2.598	2.598	3.75	3.75	5.313	5.313	7.5	7.5	13
		+0.003	+0.003	+0.001	+0.001	+0.002	+0.003	+0.003	+0.003	+0.003	+0.005	+0.005	+0.003	+0.003	+0.003	+0.003	+0.005
		-0.000	-0.000	-0.001	-0.001	-0.000	-0.000	-0.000	-0.000	-0.000	-0.000	-0.000	-0.000	-0.000	-0.000	-0.000	-0.000
X		11/8	11/8	17/16	11/8	111/32	123/32	123/32	123/32	13/8	23/16	23/16	45/16	41/8	37/16	41/4	101/2
Y	PCD	1.5	1.5	2.5	3	3	4.13	4.13	4.13	6	7.75	8.75	10.25	10.25	11	11	16
Z	DIA	9/32	9/32	7/16	13/32	11/16	13/16	13/16	13/16	11/16	15/8	13/8	13/8	1.5	17/8	17/8	23/4
	No of Holes	4	4	4	4	4	4	4	4	4	4	4	4	6	6	6	6
A-A		23/8	23/8	31/4	41/16	51/4	55/8	65/16	71/8	87/8	87/8	107/8	139/16	139/16	17	17	231/8
B-B		23/8	23/8	31/4	33/4	43/4	5	51/2	71/8	87/8	87/8	107/8	139/16	139/16	17	17	231/8

Note Dimensions are subject to change without notice.

For other dimensions and performance data refer to translating screw model. All dimensions in inches.

Upright Rotating Screw

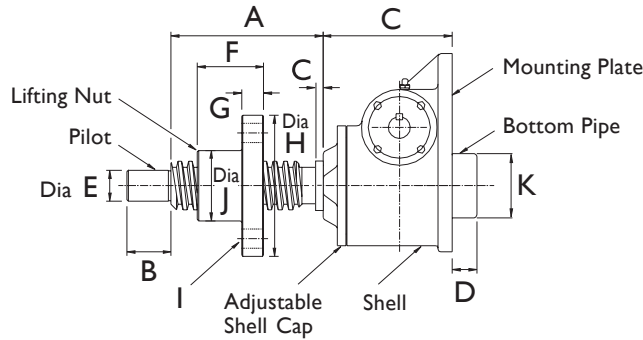

Model UM	Capacity (Short Tons)	Style	A	B	C	C'	D	E	F	G	H	I			J	K
												Holes	Dia.	P.C.D		
UM2556	0.25	1	Raise + 1.5	5/8	2 3/8	0	0	0.312	7/8	3/8	2.25	4	9/32	1.75	1	0
UM2626	0.5	1	Raise + 1 7/8	5/8	2 3/8	0	0	0.437	7/8	3/8	2.25	4	9/32	1.75	1	0
UM2502	1	1	Raise + 1.5	5/8	3 1/4	0	0	0.5	1.5	0.5	3.25	4	13/32	2 3/8	1.5	0
UM1803	2	2	Raise + 2 3/8	0.75	4 1/16	0	0	0.625	1.5	0.5	3.25	4	13/32	2 3/8	1.5	0
UM9003	2	3	Raise + 2 3/8	0.75	4 1/16	0	0	0.625	1.5	0.5	3.25	4	13/32	2 3/8	1.5	0
UM1806	5	3	Raise + 3	1	5 1/4	0	0	1	2.5	0.75	4	4	9/16	3	2	0
UM1811	10	3	Raise + 4	2	5 5/8	0	1	1.249	3	1	6	4	0.81	4.5	3	2 7/8
UM1816	15	3	Raise + 4	2	6 5/16	0	1	1.5	3	1	6.5	4	0.81	5	3.5	2 7/8
UM1821	20	3	Raise + 5	2.5	7 1/8	0	1.75	1.75	3	1	7.5	4	0.94	5.5	3.75	3 1/2
UM1826	25	3	Raise + 7	3	8 7/8	3 1/8	2	2.5	5.5	1.25	8.5	4	1 1/16	6.5	4.5	4.5
UM9036	35	3	Raise + 6	3.5	8 7/8	0	2	3	5.5	1.5	9	4	1 1/16	7	5	4.5
UM1851	50	2	Raise + 7	4	10 7/8	1 1/8	2.5	3.5	6	2	10	6	1 1/16	8	6	5.56
UM9076	75	2	Raise + 8.5	4.5	13 9/16	1 1/16	2.5	4	7.5	2	12.5	6	1 1/8	10	7	6 5/8
UM1897	100	4	Raise + 8	5	17	2	5	5	7	2	14	6	1 1/8	11	8	7
UM18151	150	4	Raise + 9.75	5.5	17	2	3.5	5.5	8.75	2.5	15.5	6	1.5	12.5	9	8

Inverted Rotating Screw

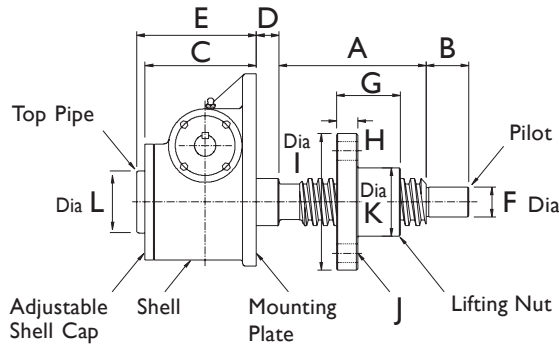

Model DM	Capacity (Short Tons)	Style	A	B	C	D	E	F	G	H	I	J			K	L
												Holes	Dia.	P.C.D		
DM2556	0.25	1	Raise + 1.5	5/8	2 3/8	3/8	2 3/8	0.312	7/8	3/8	2.25	4	9/32	1.75	1	0
DM2626	0.5	1	Raise + 1 7/8	5/8	2 3/8	3/8	2 3/8	0.437	7/8	3/8	2.25	4	9/32	1.75	1	0
DM2502	1	1	Raise + 1.5	5/8	3 1/4	0.25	3 1/4	0.5	1.5	0.5	3.25	4	13/32	2 3/8	1.5	0
DM1803	2	2	Raise + 2 3/8	0.75	4 1/16	5/8	4 1/16	0.625	1.5	0.5	3.25	4	13/32	2 3/8	1.5	0
DM9003	2	3	Raise + 2 3/8	0.75	4 1/16	5/8	4 1/16	0.625	1.5	0.5	3.25	4	13/32	2 3/8	1.5	0
DM1806	5	3	Raise + 3	1	5 1/4	2	5 1/4	1	2.5	0.75	4	4	9/16	3	2	0
DM1811	10	3	Raise + 4	2	5 5/8	1.13	5 5/8	1.249	3	1	6	4	0.81	4.5	3	0
DM1816	15	3	Raise + 4	2	6 5/16	0.81	6 1/2	1.5	3	1	6.5	4	0.81	5	3.503	2 7/8
DM1821	20	3	Raise + 5	2.5	7 1/8	0.63	7 7/8	1.75	3	1	7.5	4	0.94	5.5	3.75	4.5
DM1826	25	3	Raise + 7	3	8 7/8	1.5	9 7/8	2.5	5.5	1.25	8.5	4	1 1/16	6.5	4.5	4.5
DM9036	35	3	Raise + 6	3.5	8 7/8	0.88	9 7/8	3	5.5	1.5	9	4	1 1/16	7	5	4.5
DM1851	50	2	Raise + 7	4	10 7/8	2 5/8	11 1/2	3.5	6	2	10	6	1 1/16	8	6	5.56
DM9076	75	2	Raise + 8.5	4.5	13 9/16	3 5/8	15 1/16	4	7.5	2	12.5	6	1 1/8	10	7	6 5/8
DM1897	100	4	Raise + 8	5	17	2	18	5	7	2	14	6	1 1/8	11	8	7
DM18151	150	4	Raise + 9.75	5.5	17	2	17	5.5	8.75	2.5	15.5	6	1.5	12.5	9	8

Note: Dimensions subject to change without notice.

Model	Upright	M2555	M2625	M2501	M1802	M9002	M1805	M1810	M1815
	Inverted	M2554	M2624	M2500	M1801	M9001	M1804	M1809	M1814
Capacity (Short Tons)		0.25	0.5	1	2	2	5	10	15
Threaded End									
A		3/8-24 UNF-2A	3/8-24 UNF-2A	1/2-13 UNC-2A	3/4-10 UNC-2A	3/4-10 UNC-2A	1-8 UNC-2A	1 1/2-6 UNC-2A	1.75-5 UNC-2
B	DIA	0.5	5/8	0.75	1	1	1.5	2	2.25
C		0.75	1	0.75	1 1/8	1 1/8	1 1/8	1 5/8	2
D	Upright	4	4	5 3/8	6	6	8	8.75	9.75
	Inverted	2	2	2	2.5	2.5	3.5	4.25	4.25
E		1/8	1/8	1/8	1/8	0.19	0.19	0.25	0.25
Clevis End									
F		13/64	17/64	21/64	13/32	13/32	21/32	25/32	29/32
G		3/8	0.5	0.5	0.75	0.75	1	1.25	1.5
H		0.5	5/8	0.75	1	1	1.5	2	2.25
I		0.375	0.5	0.375	0.75	0.75	1	1.25	1.25
K	Upright	4	4	5	5.25	5.25	7	7.5	8.5
	Inverted	2	2	1 5/8	1.75	1.75	2.5	3	3

Model	Upright	M1820	M1825	M9034	M1850	M9075	M1899	M18150	M2250
	Inverted	M1819	M1824	M9034	M1849	M9074	M1898	M18149	M2249
Capacity (Short Tons)		20	25	35	50	75	100	150	250
Threaded End									
A		2-4.5 UNC-2A	3-4 UNC-2A	3.25-4 UNC-2A	4-4 UNC-2A	4-12 UNC-2A	4 1/2-12 UNC-2A	5-12 UNC-2A	8-12 UNC-2A
B	DIA	2.5	3.375	3.75	4.5	5	6	7	9
C		2.25	3.25	3.75	4.25	4.5	5	5	6
D	Upright	11.5	13.75	15	17.5	20.5	25	25	30
	Inverted	5	5.75	7	8	9.5	12	12	12
E		0.25	0.25	0.25	0.25	0.25	0.25	0.25	0.25
Clevis End									
F		1 1/32	1 9/32	1 17/32	1 25/32	2 1/32	2 17/32	2 25/32	3 17/32
G		1.75	2.25	2.5	3.25	3.5	4.25	5.25	7
H		2.5	3.375	3.75	4.5	5	6	7	9
I		1.5	1.75	2	2.5	2.5	3	3	4
K	Upright	10	12	13	15	18	24	24	30
	Inverted	3.5	4	5	5.5	7	9	9	12

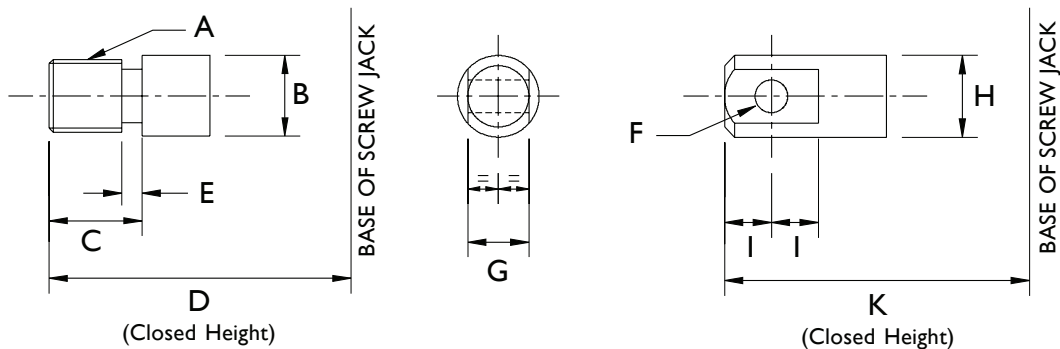

- Note
1. All dimensions in inches.
 2. Dimensions subject to change without notice.

Note For other performance and dimension information refer to translating screw models

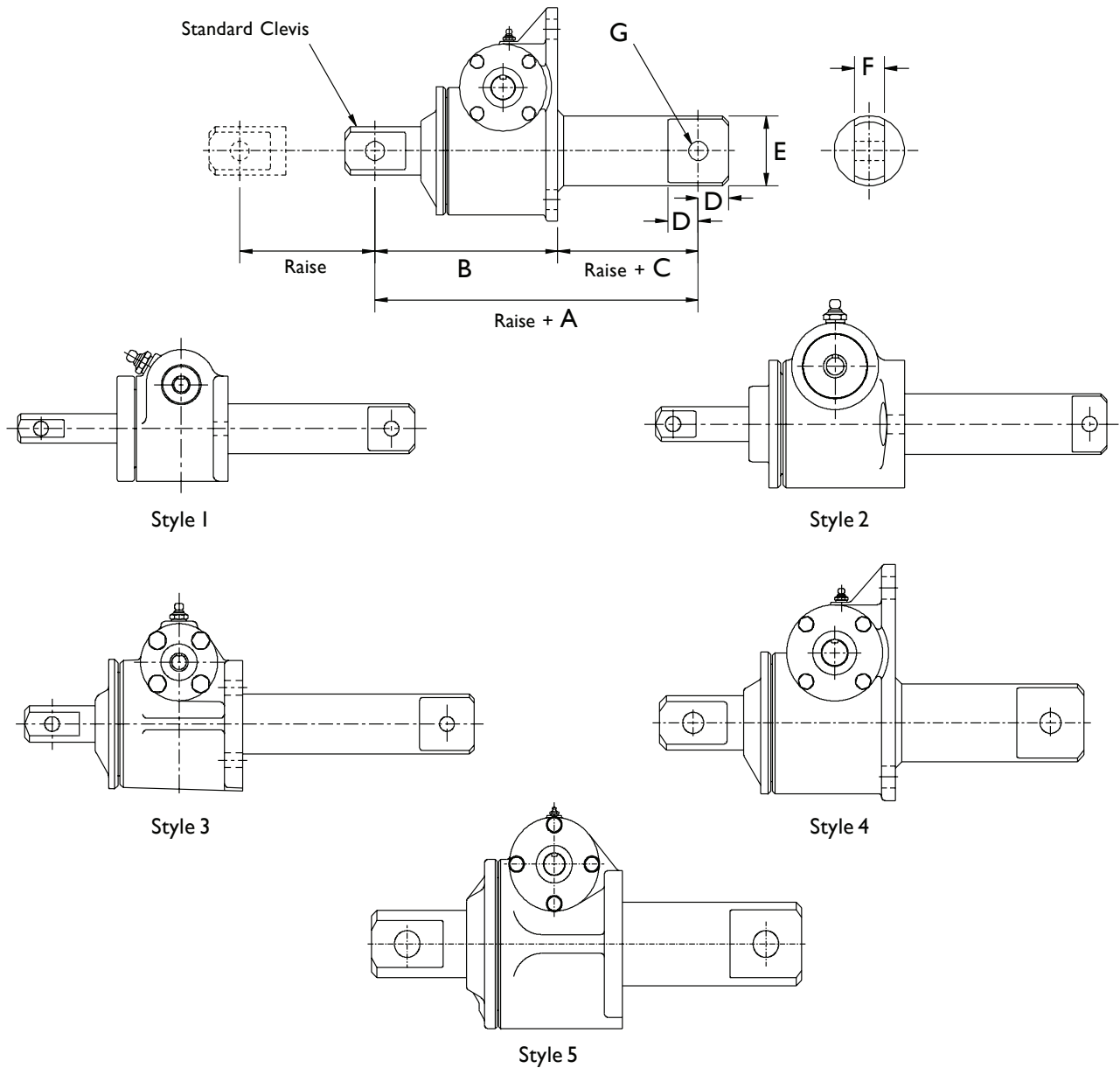

Model	CCM 2555	CCM 2625	CCM 2501	CCM 1802	CCM 1805	CCM 1810	CCM 1815	CCM 1820	CCM 1825	CCM 9035	CCM 1850
Capacity (Short Tons)	0.25	0.5	1	2	5	10	15	20	25	35	50
Style	1	1	2	3	4	4	4	4	4	4	5
A	5.5	5.5	6.5	6.75	9	10.25	11.25	13.5	16	17	19
B	4	4	5	5.25	7	7.5	8.5	10	12	13	15
C	1.5	1.5	1.5	1.5	2	2.75	2.75	3.5	4	4	4
D	-	-	-	0.75	1	1.25	1.25	1.5	1.75	2	2.5
E	1 1/16	1 1/16	1 5/16	1 21/32	2.38	2.88	2.88	3.5	4.5	4.5	5 9/16
F	3/8	0.5	0.5	0.75	1	1.25	1.5	1.75	2.75	2.5	3.25
G	13/64	17/64	21/64	0.41	0.66	0.78	0.91	1.03	1.28	1.53	1 25/32
Max Allowable Raise (compression) at load (lb)	5.75 500	9.25 1000	9.75 1500	14.5 3000	22.5 6500	31 12000	37 3/8 16000	39.25 20000	54 38000	73.5 61000	94.5 98000
Max Raise at Rated Load (compression)	5.75	9.25	8.25	12 1/8	17	22 7/8	25 7/8	29.25	47	69	90.5

Note 1. All dimensions in inches unless otherwise stated.
 2. Dimensions subject to change without further notice.

M-Series machine screw jacks with anti-backlash nuts for applications where a reversal of loading from tension to compression is encountered. These are based on the 1800 and 9000 series screw jacks and are designated 4800 and 9400 series.

Anti-Backlash Features

- Reduction in the vertical backlash between the screw and the worm gear nut to a practical minimum for smoother, more precise operation and minimum wear.
- Acts as a safety device, providing a dual nut load carrying unit, when the worm gear becomes worn.
- Wear indicator for critical applications.

The anti-backlash feature can be maintained by adjusting the shell cap until the desired amount of backlash is achieved. To avoid binding and excessive wear, do not adjust lifting screw backlash to less than 0.005".

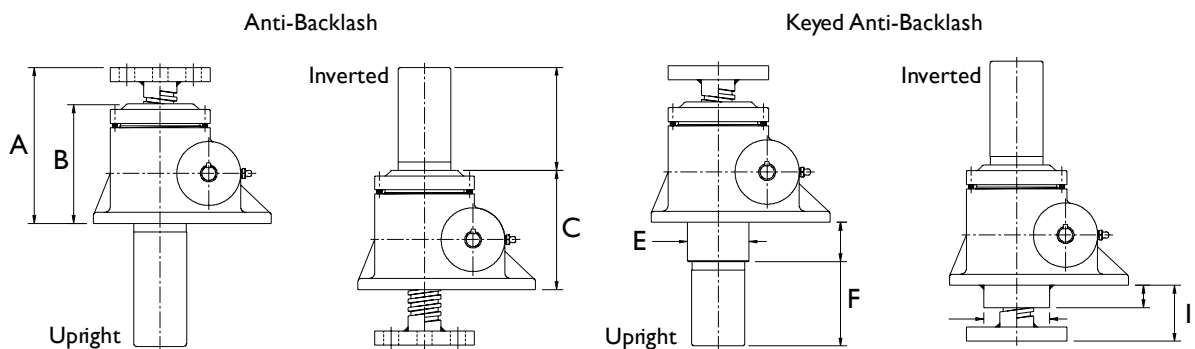
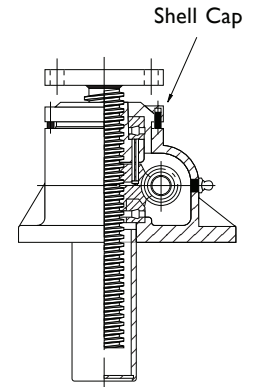

Standard Dimensions (inches)

Anti-Backlash					Keyed Anti-Backlash						
Model	A	B	C		Model	E	F			I	
M4555	4	2.38	2.38	Raise + 0.75	M4555-K	1.5	Raise + 0.75	0.75	1.5	2	0.75
M4625	4	2.88	2.43	Raise + 0.75	M4625-K	1.25	Raise + 0.75	0.81	1.25	2	0.81
M4501	5	3.84	3.38	Raise + 1.63	M4501-K	1.06	Raise + 1.13	0.75	1.5	2	0.75
M4802	5.25	3.88	3.88	Raise + 0.75	M4802-K	2.25	Raise - 0.13	1.25	2.25	1.75	0.63
M4805	7	5.43	5.43	Raise - 0.25	M4805-K	2.75	Raise + 0.38	1.75	2.75	2.5	0.88
M4810	7.25	5.75	5.75	Raise	M4810-K	3.38	Raise	2	3.38	2.75	1.13
M4815	8	6.13	6.13	Raise	M4815-K	3.63	Raise	2	3.63	2.75	1.25
M4820	9.5	7.75	7.75	Raise + 0.75	M4820-K	4.0	Raise + 0.75	1.5	4	3	1.0
M4825	12	9.69	9.69	Raise + I	M4825-K	5.5	Raise	2.25	5.5	3	1.25
M9435	13	9.44	9.44	Raise + 1.75	M9435-K	6.5	Raise + 0.69	2.38	6.5	4	1.25
M4850	14	11.75	11.75	Raise + 1.75	M4850-K	7.0	Raise + 0.75	3	7.0	5	3.0
M9475	18.5	15.25	15.25	Raise + I	M9475-K	7.5	Raise + I	4	7.5	6.5	4.0
M4899	26.5	18.06	18.06	Raise + 0.5	M4899-K	8.5	Raise + I	5	8.5	12	5.0
M48150	26.5	18.06	18.06	Raise + 0.5	M48150-K	10	Raise + I	5.56	10	12	5.56

Torque and Efficiencies for Standard Anti-Backlash Screw Jacks

Model	Upright	M4555	M4625	M4501	M4802	M4805	M4810	M4815	M4820	M4825	M9435	M4850	M9475	M4899	M48150
	Inverted	M4554	M4624	M4500	M4801	M4804	M4809	M4814	M4819	M4824	M9434	M4849	M9474	M4898	M48149
Capacity, Short Tons		0.25	0.5	1	2	5	10	15	20	25	35	50	75	100	150
Start-Up Torque at Full Load (in.lb)	Std Ratio	15	24	60	135	500	1005	1658	2261	3712	5083	8022	13204	17004	31330
	Option I	-	-	27	56	228	526	904	1228	1997	3014	4542	7314	9210	17225
Efficiency Rating	Std Ratio	0.277	0.168	0.212	0.196	0.199	0.198	0.180	0.176	0.134	0.137	0.124	0.113	0.117	0.127
	Option I	-	-	0.117	0.119	0.109	0.126	0.110	0.108	0.083	0.077	0.073	0.068	0.072	0.077
Weight with Base Raise of 6" (lbs)		2.5	2.5	6	18	37	55	70	101	197	250	440	750	1325	1475

Note For loads from 25% to 100% of screw jack capacity, torque requirements are proportional to the load.

- Protects the screw from dust and dirt.
- Helps maintain the proper lubrication.
- Guards against moisture and corrosive contaminants.
- Boots are made of neoprene-coated nylon with sewn construction. Other materials are available for applications involving high temperatures, highly corrosive atmospheres and other special conditions.

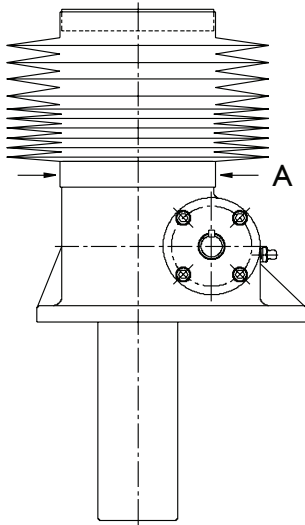

Boot Installation Data

Capacity	500 lb	1000 lb	1 Ton	2 Ton	5 Ton	10 Ton	15 Ton	20 Ton
Shell Cap Diameter "A"	2.25	2.25	2.75	3.5	4.5	5.25	5.625	6

Capacity	25 Ton	35 Ton	50 Ton	75 Ton	100 Ton	150 Ton	250 Ton
Shell Cap Diameter "A"	7.5	7.875	11.25	13.25	10	10	16

Note: For horizontal installation exceeding 18" of travel, internal boot guides are recommended.

Upright Imperial Machine Screw Jacks with Bellows Boots

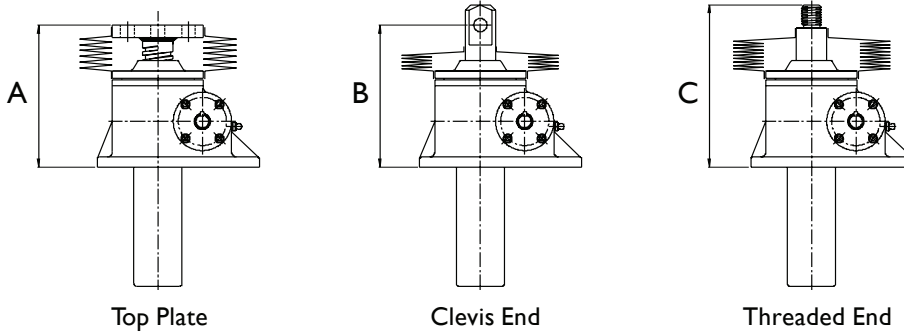

Model No	Boot O.D.	Raise																							
		0-12"			12"-18"			18"-24"			24"-30"			30"-36"			36"-48"			48"-60"			60"-72"		
		A	B	C	A	B	C	A	B	C	A	B	C	A	B	C	A	B	C	A	B	C	A	B	C
M2555	4.25	4	4	4 1/4	4 3/4	4 5/8	5	-	-	-	-	-	-	-	-	-	-	-	-	-	-	-	-	-	-
M2625	4.25	4	4	4 1/2	4 1/4	4 5/8	4 1/2	4 1/4	4 5/8	4 1/2	-	-	-	-	-	-	-	-	-	-	-	-	-	-	-
M2501	6.0	4 1/2	5	5 3/8	5 1/8	5 5/8	6	5 1/2	5 3/4	6 1/4	-	-	-	-	-	-	-	-	-	-	-	-	-	-	-
M1802	7.75	5 1/4	6 1/2	7 1/4	5 3/4	7 1/2	8 1/4	5 3/4	7 1/2	8 1/4	5 3/4	7 1/2	8 1/4	6 1/4	8 1/2	9 1/4	-	-	-	-	-	-	-	-	-
M9002	7.75	5 1/4	6 1/2	7 1/4	5 1/4	7 1/2	8 1/4	5 3/4	7 1/2	8 1/4	5 3/4	7 1/2	8 1/4	6 1/4	8 1/2	9 1/4	-	-	-	-	-	-	-	-	-
M1805	7.75	7	7	8	7	8 1/2	9 1/2	7	8 1/2	9 1/2	8	8 1/2	9 1/2	8	10	11	-	-	-	-	-	-	-	-	-
M1810	9.0	7 1/4	8 1/2	9 3/4	7 1/4	8 1/2	9 3/4	7 1/4	9 1/2	10 3/4	8 1/2	9 1/2	10 3/4	8 1/2	9 1/2	10 3/4	9 1/2	10 1/2	11 3/4	10 1/2	11 1/2	12 3/4	11 1/2	12 1/2	13 3/4
M1815	9.0	8	8 1/2	9 3/4	8	10	11 1/4	8	10	11 1/4	9	10	11 1/4	9	10	11 1/4	11	12	12 1/4	11	12	13 1/4	12	13	14 1/4
M1820	9.0	9 1/4	10	11 1/2	9 1/4	11	12 1/2	9 1/4	11	12 1/2	10 1/2	12	13 1/2	10 1/2	12	13 1/2	11 1/2	13	14 1/2	12 1/2	14	15 1/2	13 1/2	15	16 1/2
M1825	10.75	11	12	13 3/4	11	12	13 3/4	11	13 1/4	15	12	13 1/4	15	12	14 1/2	16 1/4	13	15 3/4	17 1/2	14	15 3/4	17 1/2	15	16 3/4	18 1/2
M9035	11.0	12	13	15	12	13	-	12	13	15	12	13 3/4	15 3/4	12	13 3/4	15 3/4	12 7/8	14 3/4	16 3/4	13 3/4	15 1/2	17 1/2	14 3/4	16 1/2	18 1/2
M1850	14.5	13	15	17 1/2	13	16	18 1/2	13	16	18 1/2	14	16	18 1/2	14	17	19 1/2	15	18	20 1/2	16	18	20 1/2	17	19	21 1/2
M9075	16.5	17 1/2	19	21 1/2	17 1/2	19	21 1/2	17 1/2	19	21 1/2	17 1/2	19	21 1/2	17 1/2	19	21 1/2	18 1/2	20	20 1/2	19 1/2	21	23 1/2	20 1/2	22	24 1/2
M1899	11.25	24	24	25	24	24	25	24	24	25	24	24	25	24 1/2	24 1/2	25 1/2	25	25 1/2	26 1/2	26	26 1/2	27 1/2	27	27 1/2	28 1/2
M18150	12.25	24	24	25	24	24	25	24	24	25	24	24	25	24 1/2	24 3/8	25 3/8	25	25 1/8	26 1/8	26	26 7/8	26 7/8	27	26 5/8	27 5/8
M2250	16.0	30	-	-	30	-	-	30	-	-	30 1/2	-	-	30 1/2	-	-	31 1/2	-	-	31 1/2	-	-	32	-	-

- Note
1. (-) indicates "not applicable".
 2. For lengths of raise not detailed in the above table consult PowerJacks Ltd.
 3. Dimensions subject to change without notice.
 4. All dimensions in inches

Inverted Machine Screw Jacks with Bellows Boots

1898 - 18149 only

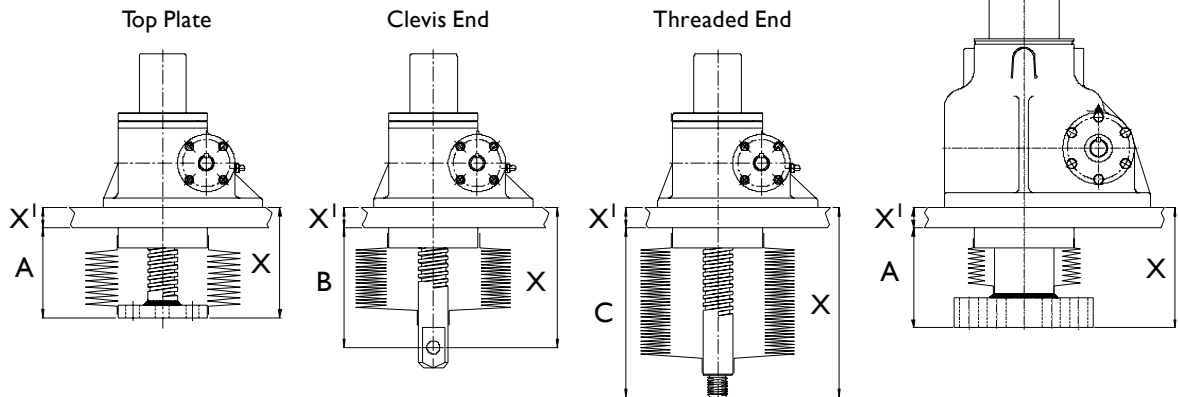

Finding minimum closed dimensions

- Add your structure thickness X^l to A, B, or C from the appropriate chart to find the minimum closed dimension.
- Other styles and sizes of boots can be supplied.
- In order to use a standard boot, make the mounting plate diameter the same as the shell cap diameter of the appropriate screw jack
- When boots are required for rotating screw jacks, consult Power Jacks Ltd.

Model No	Raise (Inches)											
	1"-6"			7"-12"			13"-18"			19"-24"		
	A	B		A	B	C	A	B		A	B	
M2554	2	2 3/8	2	2	2 3/8	2	2 1/8					
M2624	2	2 5/8	2 1/8	2	2 5/8	2 1/8	2 1/8	3 1/4	2 3/4			
M2500	2 1/16	3	2 5/8	2 1/16	3	2 5/8	2 11/16	3 5/8	3 1/4	3 1/16	4	3
M1801 & M9001	2 3/8	4 3/8	3 5/8	2 3/8	4 3/8	3 5/8	2 7/8	5 3/8	4 5/8	3	5 3/8	4 5/8
M1804	3 3/16	4 3/16	3 3/16	3 3/16	4 3/16	3 3/16	3 3/16	5 11/16	4 11/16	3 1/2	5 11/16	4 11/16
M1809	3 1/4	5 3/4	4 1/2	3 1/4	5 3/4	4 1/2	3 1/4	5 3/4	4 1/2	3 9/16	7	5 3/4
M1814	3 1/4	5 1/4	4	3 1/4	5 1/4	4	3 1/4	6 3/4	5 1/2	3 9/16	6 3/4	5 1/2
M1819	3 1/4	5 9/16	4 1/16	3 1/4	5 9/16	4 1/16	3 1/4	6 9/16	5 1/16	3 1/4	6 9/16	5 1/16
M1824	3 3/8	6 3/4	5	3 3/8	6 3/4	5	3 3/8	6 3/4	5	3 3/8	7 3/4	6
M9034	4 1/2	7 1/2	5 1/2	4 1/2	7 1/2	5 1/2	4 1/2	7 1/2	5 1/2	4 1/2	7 1/2	5 1/2
M1849	4 7/8	9 5/16	6 13/16	4 7/8	9 5/16	6 13/16	4 7/8	1 5/16	7 13/16	4 7/8	1 5/16	7 13/16
M9074 a,b,c	2 3/8	6 7/8	4 7/8	2 3/4	7 1/4	5 1/4	3	7 1/2	5 1/2	3 3/8	7 7/8	5 7/8
M1898	* 7 11/16	* 8 11/16	** 7 11/16	* 7 11/16	* 8 11/16	** 7 11/16	* 7 11/16	* 8 11/16	** 7 11/16	* 7 11/16	* 8 11/16	** 7 11/16
M18149	* 7 11/16	* 8 11/16	** 7 11/16	* 7 11/16	* 8 11/16	** 7 11/16	* 7 11/16	* 8 11/16	** 7 11/16	* 7 11/16	* 8 11/16	** 7 11/16

Value of X = a) If $A+X^l$ is less than 5 1/2", X = 5 1/2" b) If $B+ X^l$ is less than 9 1/2", X = 9 1/2" c) If $C+ X^l$ is less than 7", X = 7"
 *If $A+X^l$ and $B+ X^l$ are less than 12", X = 12". If greater than 12", use dimensions shown.
 ** If $C+ X^l$ is less than 9", X = 9". If greater than 9", use dimensions shown.

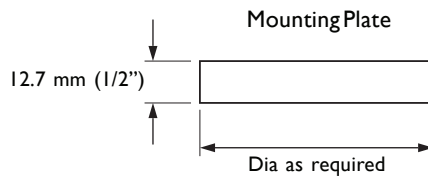

Note Same values can be used for M4800 Series Screw Jacks Units.

To be manufactured by installer

- Note
1. For lengths of raise not detailed in the above table consult Power Jacks Ltd.
 2. Dimensions subject to change without notice.
 4. All dimensions in inches

Note For other performance and dimension information refer to translating screw models.

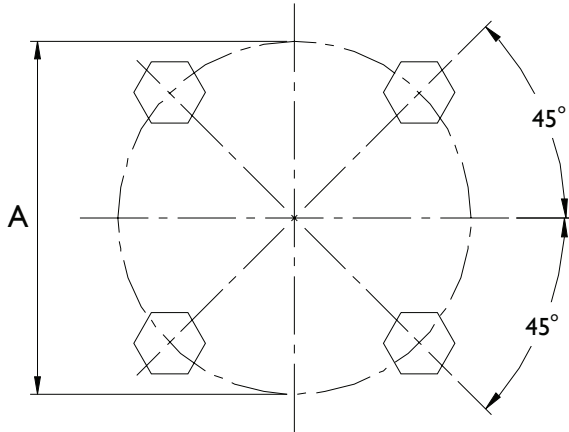

Configuration A

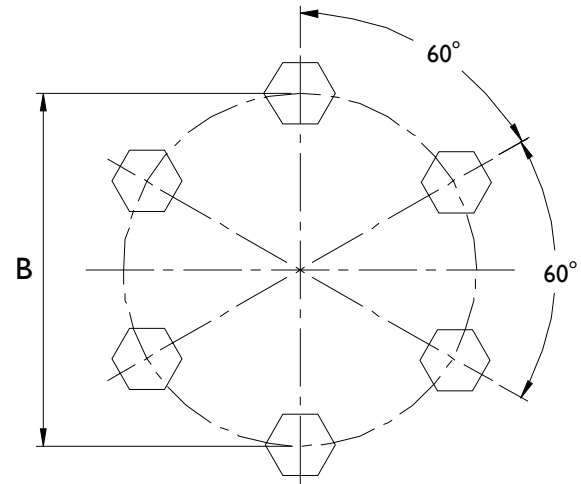

Configuration B

Model	'B' Bolt P.C.D. (inch)	Bolt Information	Configuration
M2555	-	No Flange Bolts	-
M2625	-	No Flange Bolts	-
M2501	-	No Flange Bolts	-
M1802 & M9002	1 11/16	1/4 - 20 x 3/4" Long	A
M1805	2 3/8	5/16 - 18 x 3/4" Long	A
M1810	2 3/4	5/16 - 18 x 3/4" Long	A
M1815	2 3/4	5/16 - 18 x 1" Long	A
M1820	3 1/2	3/8 - 16 x 1 1/4" Long	A
M1825	4 1/8	3/8 - 16 x 1 1/4" Long	A
M9035	4 1/4	1/2 - 13 x 1 1/4" Long	A
M1850	5 1/4	5/8 - 11 x 1 1/2" Long	A
M9075	5 3/4	5/8 - 11 x 1 1/2" Long	B
M1899	6 1/4	5/8 - 11 x 1 1/2" Long	B
M18150	6 1/4	5/8 - 11 x 1 1/2" Long	B
M2250	8 1/4	3/4 - 10 x 2" Long	B

- Note
1. All dimensions in inches unless otherwise stated.
 2. Dimensions are subject to change without notice.

Motor Adaptors for Inch Screw Jacks

- Standard adaptors for inch screw jacks available on request.
- Designed for standard IEC frame sizes.
- Allows direct motor coupling on either side of the screw jack input shaft.
- Complete with drive coupling and mounting hardware.
- NEMA frame size versions available on request.
- Adaptors for other mounting arrangements available on request.

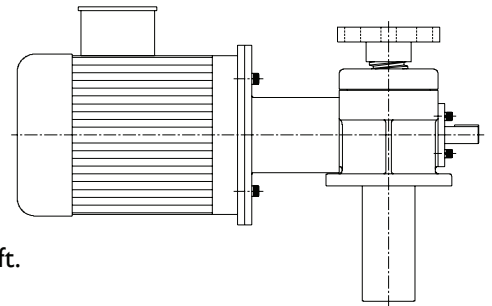

Note: When direct coupling a motor to an a screw jack , it is necessary to match motor power to screw jack load so the motor does not exceed the maximum screw jack power.

RLS-51 Rotary Limit Switch Adapters

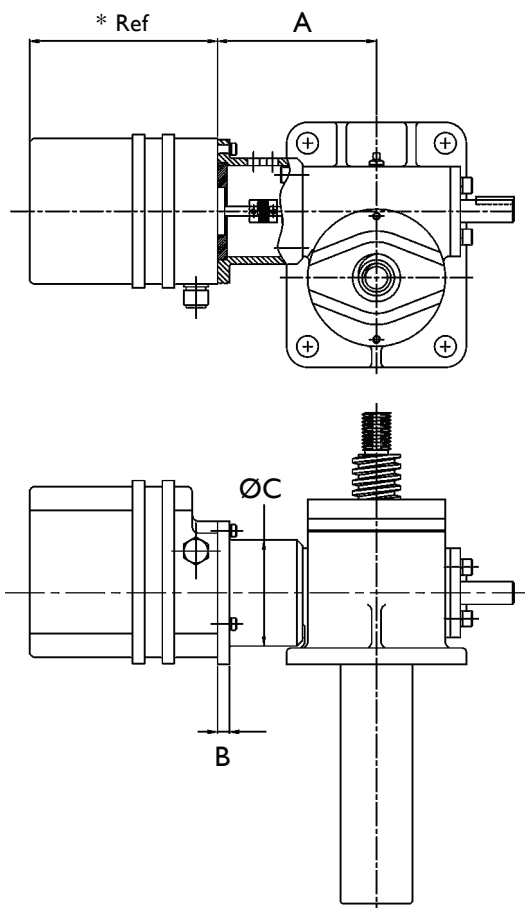

Rotary limit switches can be used as end of travel limit switches with the option of intermediate switches as well. These units are mounted onto a screw jacks free worm shaft and offer an alternative where bottom pipe mounted limit switches are not possible e.g. rotating screw jacks. Up to 8 limit switches can be accommodated in one unit.

For mounting details please consult Power Jacks.

The mounting kit includes the flexible coupling and drive adaptor.

The SKA rotary limit switch is a compact 2-position limit switch designed for screw jack and linear actuator applications.

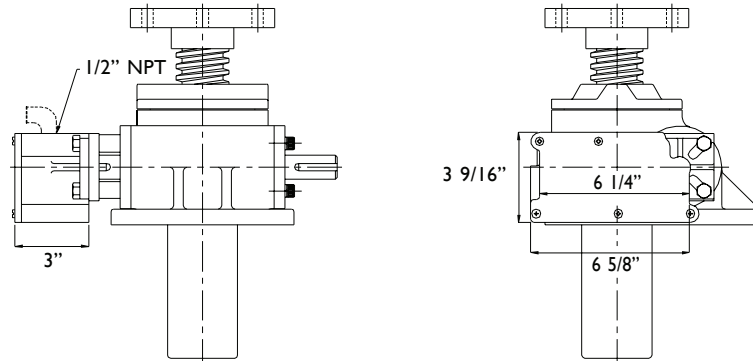

Actuator Mounted

- Note
1. All dimensions are in inches unless otherwise stated.
 2. Dimensions are subject to change without notice.

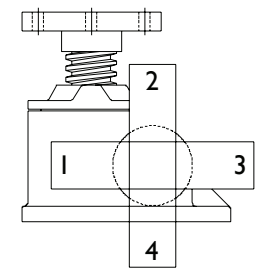

Position Number of Switch

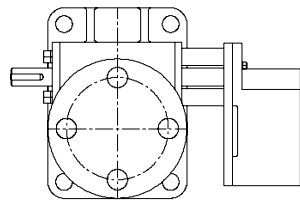

Typical top view showing switch mounted on RH worm extension

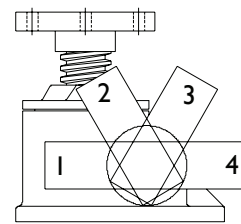

75, 100 & 150 Tons Imperial models only

Screw Jack Capacity (Short Ton)	Extended Mount								Closed Mount							
	RH				LH				RH				LH			
	1	2	3	4	1	2	3	4	1	2	3	4	1	2	3	4
2 & 3	C	A & B	B & D	-	B & D	A & B	C	-	-	-	3	4	-	-	-	-
5	✓	A	D	C	D	A	✓	C	✓	A & B	D	-	D	A & B	✓	-
10	✓	A	D	C	D	A	✓	C	✓	A & B	D	-	D	A & B	✓	-
15	✓	A	D	C	D	A	✓	C	-	A & B	D	-	D	A & B	-	-
20	✓	A	✓	C	✓	A	✓	C	✓	A & B	✓	-	✓	A & B	✓	-
25	✓	✓	✓	C	✓	✓	✓	C	✓	B	✓	-	✓	B	✓	-
35	✓	✓	✓	C	✓	✓	✓	C	✓	B	✓	-	✓	B	✓	-
50	✓	✓	✓	C	✓	✓	✓	C	-	✓	✓	-	-	✓	✓	-
75	✓	✓	✓	C	✓	✓	✓	C	-	✓	✓	-	-	✓	✓	-
100	✓	✓	✓	✓	✓	✓	✓	✓	-	✓	✓	✓	-	✓	✓	✓
150	✓	✓	✓	✓	✓	✓	✓	✓	-	✓	✓	✓	-	✓	✓	✓

- Note
- For 2 & 3 Ton inverted position, extended mount position (2) is the only one practical.
 - (A) Special Closed Height. (B) Boot Interference Unit. (C) Rotary Limit Switch extends below base of screw jack.
 - (D) Sealed electric elbow would extend below base of screw jack (✓) Recommended. (-) Not Recommended
 - Extended Mount is Standard.

SKA Limit Switch Field Installation Dimensions

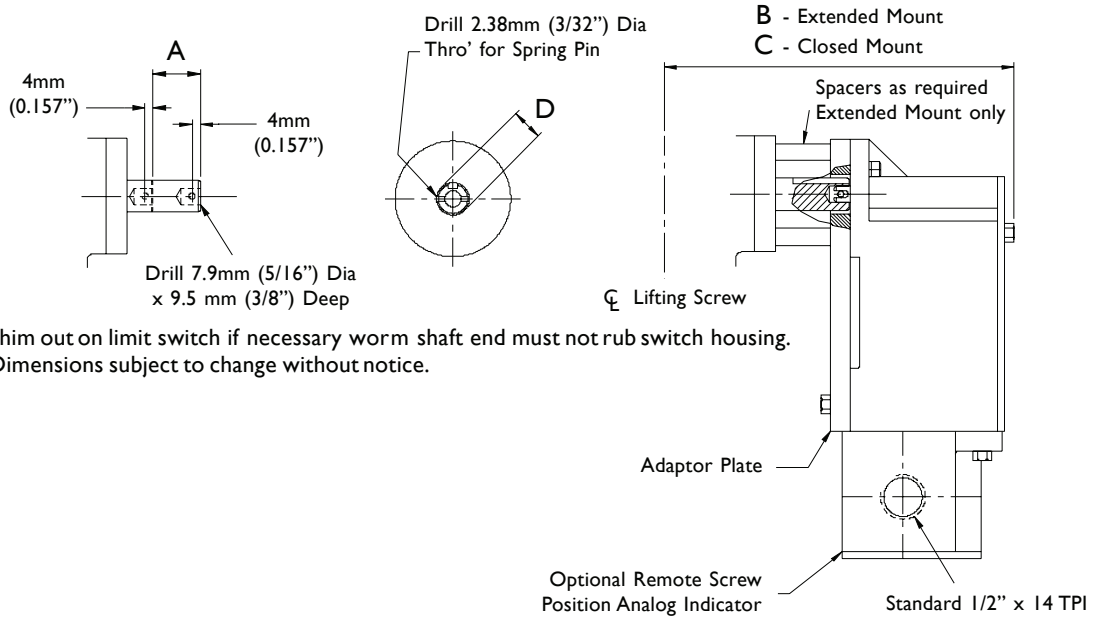

Note Shim out on limit switch if necessary worm shaft end must not rub switch housing. Dimensions subject to change without notice.

Model (Short Ton)	A Cut-off Closed Mount (inch)	B Extended Mount (inch)	C Closed Mount (inch)	D Worm Shaft Dia. (inch)
2	-	6.75	-	0.500
3	1 9/32	6.75	5.5	0.625
5	1 17/32	7.75	6.25	0.750
10	1 21/32	8.75	7 1/8	1.000
15	1 29/32	8.75	6 7/8	1.000
20	1 3/8	8.75	7 13/32	1.000
25	2 7/32	10.25	8 1/16	1.375
35	2 7/32	10.25	8 1/16	1.375
50	4 21/32	14.25	9 5/8	1.500
75	4.5	15.25	10.75	1.750
100	3.75	14.75	11 1/32	1.750
150	3.75	14.75	11 1/32	1.875

Note 1. All dimensions are in inches unless otherwise stated.
 2. Dimensions are subject to change without notice.

Advantages

- Capacity from 2 Tons through to 100 Tons.
- Worm gear ratios from 6:1 to 36:1
- Corrosion resistant.
- Stainless steel hardware
- Sealed gear cavity keeps water and other contaminants out.
- Anti-Backlash models available.
- Available with keyed lifting screws for translating screw models.
- Available in upright and inverted rotating screw models with travelling nut.
- Can be retrofitted into applications where non-stainless steel screw jacks have been previously used.

Optional Features

- Closed heights
- Materials
- Lifting screw ends
- With Stop Nuts
- Worm shaft extensions
- With bellows boots
- Lifting screw thread pitches

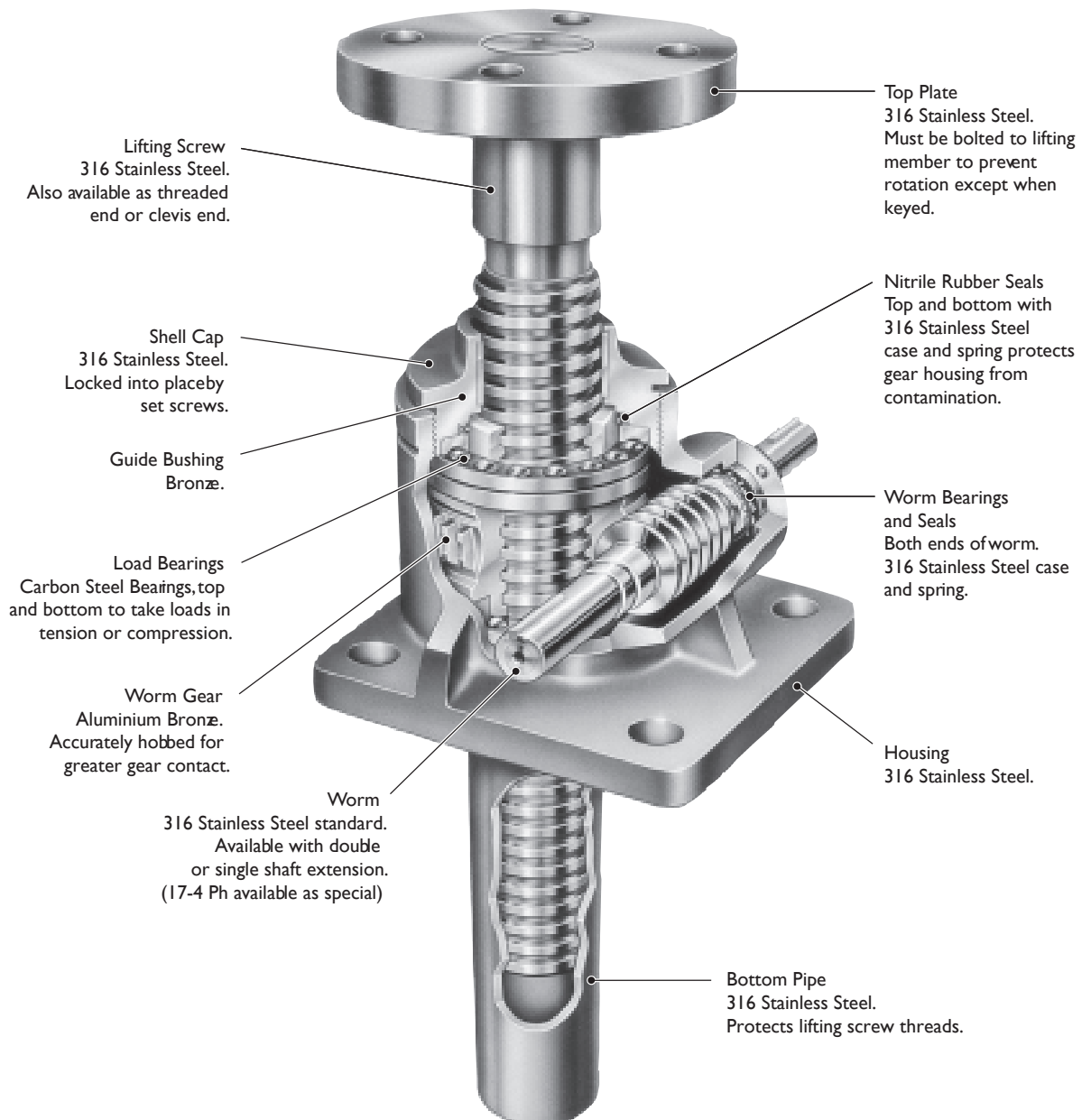

Screw Jack Model	Upright	SM-1802	SM-1805	SM-1810	SM-1815	SM-1820	SM-1825	SM-9035	SM-1850	SM-1899
	Inverted	SM-1801	SM-1804	SM-1809	SM-1814	SM-1819	SM-1824	SM-9034	SM-1849	SM-1898
Capacity (Short Tons)	Sustaining	2	5	10	15	20	25	35	50	100
	Operating**	0.66	1.66	3.33	5.00	6.66	8.33	11.66	16.66	33.33
Lifting Screw	Diameter	1	1 1/2	2	2 1/4	2 1/2	3 3/8	3 3/4	4 1/2	6
	Pitch	0.250	0.375	0.500	0.500	0.500	0.666	0.666	0.666	0.750
	Form	Acme	Square	Square	Square	Square	Square	Acme	Square	Square
Worm Gear Ratios	Std. Ratio	6:1	6:1	8:1	8:1	8:1	10 2/3:1	10 2/3:1	10 2/3:1	12:1
	Optional	24:1	24:1	24:1	24:1	24:1	32:1	32:1	32:1	36:1
Turns of Worm for 1" Raise	Std. Ratio	24	16	16	16	16	16	16	16	16
	Optional	96	64	48	48	48	48	48	48	48
Max. HP per Screw Jack	Std. Ratio	2	4	5	5	5	8	8	15	25
	Optional	1/2	3/4	1 1/2	1 1/2	1 1/2	2 1/2	2 1/2	6	11
Start-Up Torque at Operating Load* (In.-lbs)	Std. Ratio	40	150	250	475	685	665	1335	2500	5335
	Optional	17	60	135	275	390	400	800	1400	2865
Efficiency Rating	Std. Ratio	0.232	0.221	0.237	0.202	0.188	0.164	0.156	0.138	0.130
	Optional	0.133	0.121	0.151	0.129	0.120	0.092	0.089	0.083	0.080
Weight with Base Raise of 6" (lbs)		19	37	55	70	96	168	250	420	1260

* For Loads 25% to 100% of screw jack capacity, torque requirements are approximately proportional to load.

** Screw jack has been de-rated for 316 Stainless Steel worm. For full load rating use 17-4 PH worm.



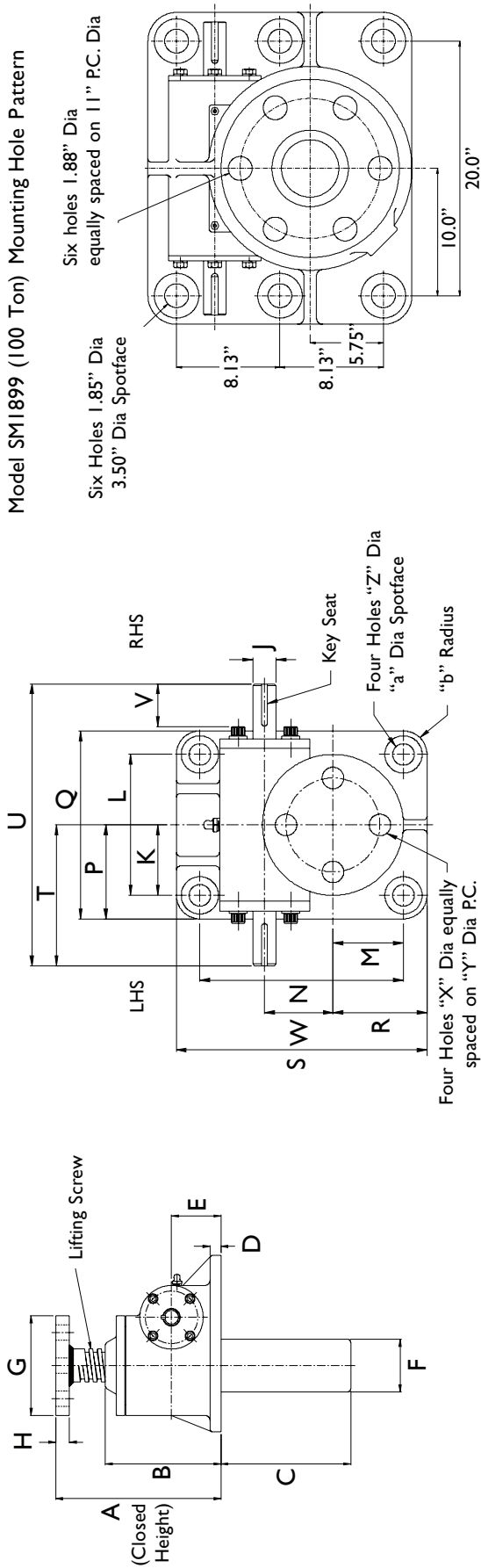

Model SM1899 (100 Ton) Mounting Hole Pattern

Model No	Capacity (Short Tons)		A	B	C	D	E	F	G	H	J	K	L	M	N	P	Q	R	S	T	U	V	W	X	Y	Z	a	b	Keyseat (b x h x L)
	Sustaining	Operating																											
SM-1802	2	0.66	5.50	4.56	Travel	.50	1.750 ±.005	1.66	4.25	.50	.500 +.000 -0.002	3.00	6.00	1.00	2.00	3.5	7.00	1.75	3.5	3.5	7.00	1.12	1.702 +.003 -0.000	.41	3.00	.41	.75	1.5	.125 x 0.060 x 1.00 LG
SM-1805	5	1.66	7.50	5.88	Travel + 3/8	.50	2.250 ±.005	2.38	4.50	.60	.749 +.000 -0.002	2.25	4.50	2.25	6.50	3.00	6.00	3.00	8.00	4.50	9.00	1.50	2.188 +.003 -0.000	.69	3.00	.69	1.19	.75	.188 x .094 x 1.25 LG
SM-1810	10	3.33	7.75	6.00	Travel + 1/4	.50	2.250 ±.005	2.88	5.75	.94	1.000 +.000 -0.002	2.88	5.75	2.00	7.00	3.75	7.50	2.88	8.75	5.50	11.00	1.80	2.598 +.003 -0.000	.81	4.13	.81	1.31	.88	.250 x .125 x 1.50 LG
SM-1815	15	5.00	8.00	6.31	Travel + 1/2	.63	2.750 ±.005	2.88	5.75	.94	1.000 +.000 -0.002	3.00	6.00	2.50	7.50	3.88	7.75	3.38	9.25	5.50	11.00	1.80	2.598 +.003 -0.000	.81	4.13	.81	1.38	.88	.250 x .125 x 1.50 LG
SM-1820	20	6.66	10.25	8.00	Travel - 1/4	.75	3.250 ±.005	3.50	5.75	.94	1.000 +.000 -0.002	3.00	6.00	3.00	8.75	4.13	8.25	4.13	11.00	5.50	11.00	1.50	2.598 +.003 -0.000	.81	4.13	1.12	1.75	1.13	.250 x .125 x 1.50 LG
SM-1825	25	8.33	11.75	9.75	Travel + 1/4	1.00	4.000 ±.005	4.50	8.50	.94	1.375 +.000 -0.002	3.75	7.50	3.75	11.00	5.13	10.25	5.13	13.75	7.00	14.00	2.30	3.750 +.003 -0.000	1.06	6.00	1.38	2.13	1.38	.313 x .156 x 2.00 LG
SM-9035	35	11.66	12.50	9.56	Travel + 1/4	1.25	4.000 ±.005	4.50	10.50	1.31	1.375 +.000 -0.002	3.75	7.50	4.50	12.50	5.13	10.25	6.00	15.50	7.00	14.00	2.10	3.750 +.003 -0.000	1.62	7.75	1.62	2.63	1.38	.313 x .156 x 2.00 LG
SM-1850	50	16.66	13.50	11.38	Travel	1.25	4.750 ±.005	5.63	11.25	1.25	1.500 +.000 -0.002	8.00	16.00	3.00	6.00	9.88	19.75	4.88	9.75	11.00	22.00	4.40	5.313 +.003 -0.000	1.38	8.75	1.88	3.25	1.88	.375 x .188 x 2.25 LG
SM-1899	100	33.33	24.00	18.50	Travel + 1/2	1.50	6.000 ±.005	7.00	14.00	2.94	1.750 +.000 -0.002	*	*	*	24.50	8.00	20.75	8.00	20.75	11.50	23.00	3.40	7.500 +.003 -0.000	*	*	*	*	*	.500 x .250 x 3.00 LG

Note: 1. Dimensions are subject to change without notice. 3. Dimensions in inches. 5. RHS = Right Hand Side

2. For models SM1802 and SM-1850 styles per section I.2.3.2. 4. LHS = Left Hand Side

Standard Stainless Steel Screw Jack Screw End Dimensions

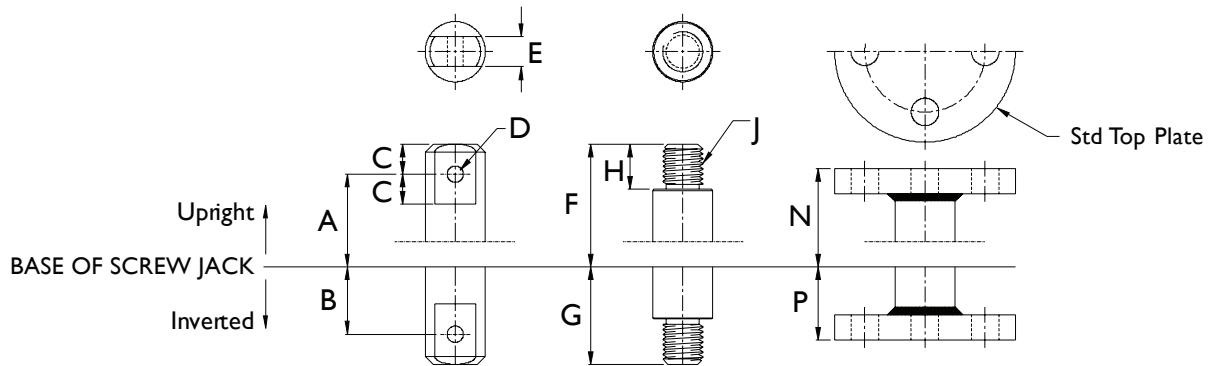

Model No	A*	B*	C	D	E	F	G	H	J	N	P
SM-1802	5 1/4"	1 3/4"	3/4"	1 3/32"	3/4"	6.0	2 1/2"	1 1/8"	3/4" 10 UNC-2A	5.25	1 3/4"
SM-1805	7"	2 1/2"	1"	2 1/32"	1"	8.0	3 1/2"	1 1/8"	1" 8 UNC-2A	7.5	2 1/2"
SM-1810	7 1/2"	3"	1 1/4"	25/32"	1 1/4"	9.25	4 1/4"	1 5/8"	1 1/2" 6 UNC-2A	7.75	2 3/4"
SM-1815	8 1/2"	3"	1 1/4"	29/32"	1 1/2"	10.25	4 1/4"	2"	1 3/4" 5 UNC-2A	8.5	2 3/4"
SM-1820	10"	3 1/2"	1 1/2"	1 1/32"	1 3/4"	12.5	5"	2 1/4"	2" 4 1/2 UNC-2A	10.25	3"
SM-1825	12"	4"	1 3/4"	1 9/32"	2 1/4"	14.5	5 3/4"	3 1/4"	2 1/2" 4 UNC-2A	11.75	3"
SM-9035	13"	5"	2"	1 17/32"	2 1/2"	15.5	7"	3 3/4"	3 1/4" 4 UNC-2A	12.5	4"
SM-1850	15"	5 1/2"	2 1/2"	1 21/32"	3 1/4"	18.0	8"	4 1/4"	4" 4 UNC-2A	13.5	3 1/2"
SM-1899	24"	9"	3"	2 17/32"	4 1/4"	25.0	12"	5"	4 1/2" 12 UNC-2A	24.0	12"

- Note
- * Closed height dimensions may increase for screw jack units supplied with bellows boots Consult Power Jacks Ltd.
 - Lifting screw listed above are not keyed. Must be held to prevent rotation.
 - Keyed lifting screws and keyed anti-backlash models are also available. Consult Power Jacks Ltd.
 - All dimensions in inches
 - Dimensions are subject to change without notice.



Advantages

- Move Loads and apply force more efficiently than machine screw jacks.
- Permit faster operation and longer life under load.
- Require less power by providing positive mechanical action.
- Permit synchronisation of multiple units.
- Capacity from 1/2 to 50 tons (4.5 kN to 450 kN).
- Handles full load in tension or compression.
- 40 models available.

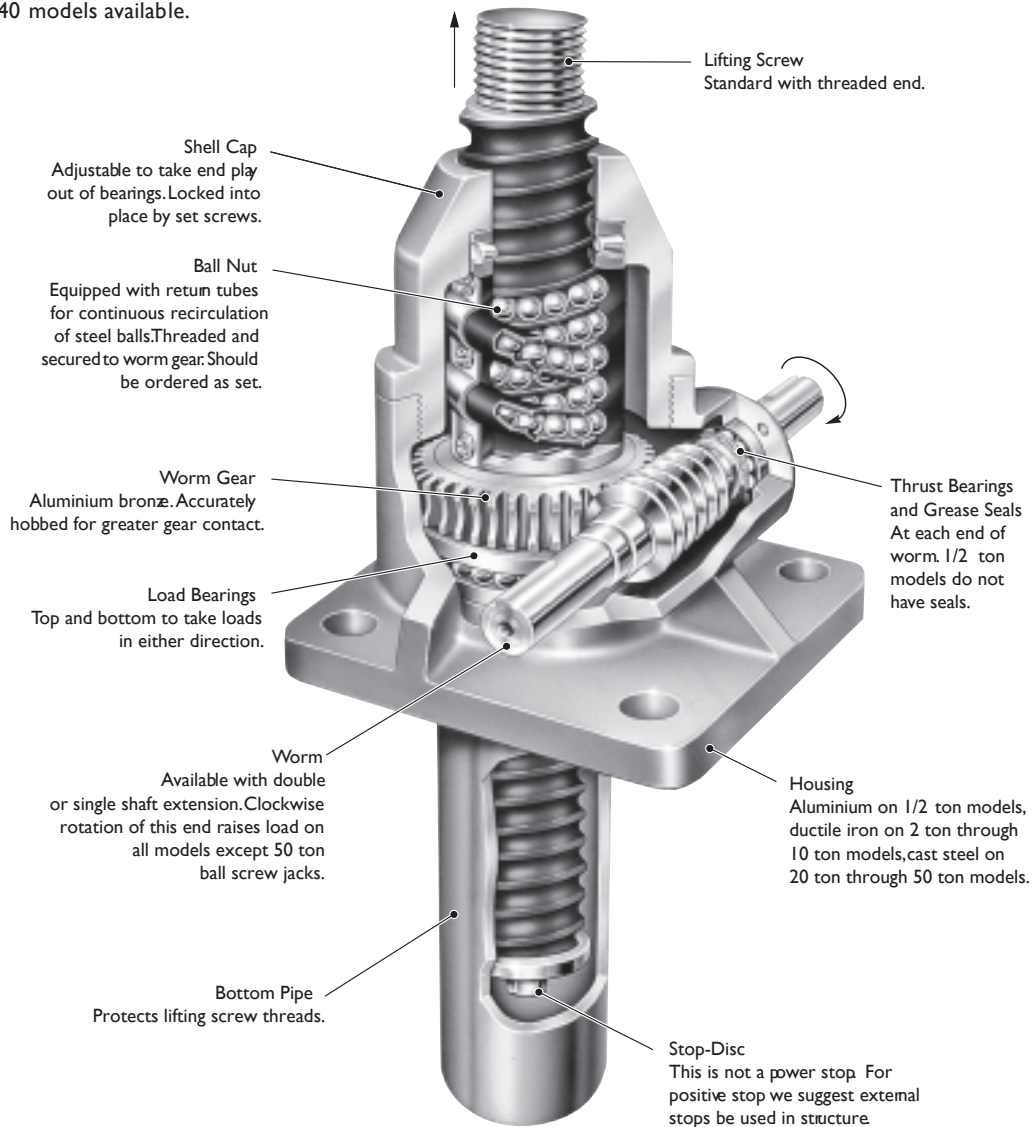

The M-Series ball screw jack gives you a single-package, positive action screw jack which can be driven by an electric, air or hydraulic motor. A ball-bearing type heat-treated screw and mating nut with rolling contact reduces friction to a bare minimum in converting torque to thrust. Overall operating efficiency is as high as 70% in some models, depending on the worm gear ratio.

M-Series ball screw jacks are available as translating or rotating screws in either upright or inverted configurations. In the translating screw type, the ball nut is fixed to the gear and the lifting screw moves up and down through the nut. In the rotating screw type, the screw is fixed to the gear and the ball nut travels along the screw.

Depending on size and type of load, models are available with raises up to 10 feet (3 metres). Raises up to 20 feet (6 metres) are available on request. Ball screw jacks may be used individually, in tandem or in multiple arrangements. Special models are available and there is no extra charge for single ended worm shafts extensions.

Features

- High Speed - Low friction permits linear motion in some models up to 300 ^{inches}/_{min} (7.62 ^m/_{min}) at 1800 rpm worm shaft speeds, providing maximum horsepower ratings are not exceeded.
- Precise Positioning - Can be controlled accurately for positioning within thousandths of an inch.
- Positive Action - Operates with a high degree of reliability without the need for costly pumps, hoses or valves
- Long-Life - Low friction means longer operating life.
- Low Power Usage - Highly efficient design means less power is needed to achieve a given thrust; power needs are much as two-thirds that of machine screw jacks.

Options

- 3 Standard Gear Ratios - Wide selection of gear ratios, increases the amount of raise rates available.
- 2 Ball Screw Lead Options - On the 2, 5 and 10 ton models there is the option of either the standard or a 1" (25.4 mm) lead for rapid raise rates.
- Screw on Ends - The standard screw jack has a threaded end to which clevis or top plates can be screwed. Note: these items are shipped loose and must be spot drilled before seating set screws in field installations.
- Bellows Boot Option - Protects the screw from dust, dirt, moisture and corrosive contaminants.
- Double Clevis End Option - Incorporates a special clevis end bottom pipe and standard clevis end on the lifting screw.

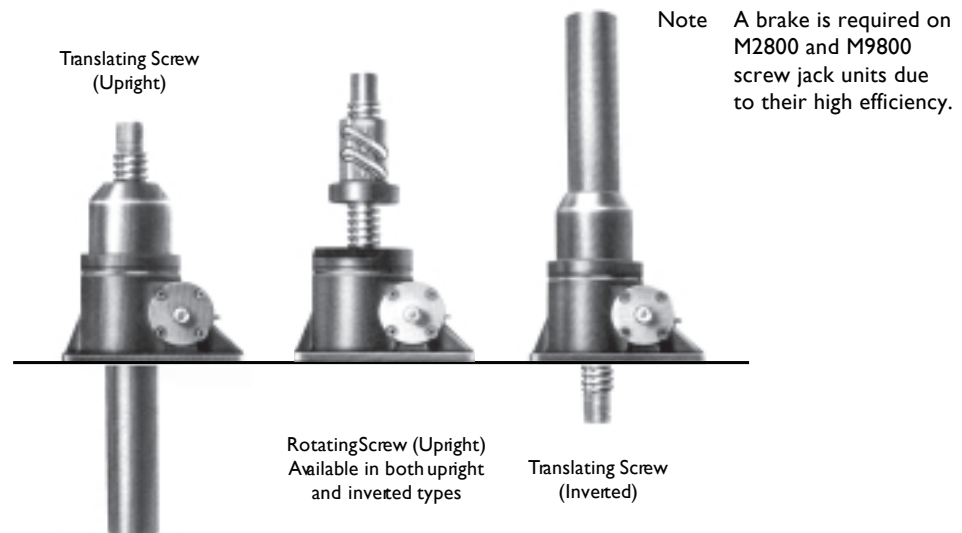

Note: Clockwise rotation of worm raises load on all models (refer previous page) except 50 ton ball screw jack counter clockwise available at extra charge.

The lifting screw end should be bolted to the lifting member to prevent the screw from rotating.

Screw jacks are equipped with "Alemite" grease fittings.

Recommended lubricants are listed in the installation and maintenance instructions.

Screw jacks supplied complete with drive shaft keys.

Attachments

IEC and Nema C-Face flanges, motors, gear boxes, reducers and couplings available for single screw jack drive or multiple screw jack arrangements

Motion control components include motor drives, Motion Controllers with operator interfaces, encoders, limit switches, potentiometers and meters with LCD display

Model	Upright	M28631	M2802 & M9802*	M28021 & M98021*	M28003	M2805	M28051	M2810	M28101	M2820	M2825	M2860
	Inverted	M28630	M2801 & M9801*	M28011 & M98011*	M28002	M2804	M28041	M2809	M28091	M2819	M2824	M2859
Capacity (Short Tons)		0.5	2	2	3	5	5	10	10	20	25	50
Lifting Screw (Inches)	Diameter	5/8	1	1	1 11/64	1.5	1.5	1.5	1.5	2.25	3	4
	Lead	0.2	0.25	1	0.413	0.474	1	0.474	1	0.5	0.66	1
Worm Gear Ratios	Standard	5:1	6:1	6:1	6:1	6:1	6:1	8:1	8:1	8:1	10 2/3:1	10 2/3:1
	Option 1	20:1	24:1	24:1	24:1	24:1	24:1	24:1	24:1	24:1	32:1	32:1
	Option 2	-	12:1	12:1	12:1	-	-	-	-	-	-	-
Turns of Worm for 1" Raise	Standard	25	24	6	14.526	12.667	6	16.888	8	16	16.16	10.66
	Option 1	100	96	24	58.104	50.667	24	50.667	24	48	48.48	32
	Option 2	-	48	12	29.052	-	-	-	-	-	-	-
Maximum HP per screw jack	Standard	1/3	2	2	2	4	4	5	5	5	8	15
	Option 1	1/6	1/2	1/2	1/2	3/4	3/4	1 1/2	1 1/2	1 1/2	2 1/2	6
	Option 2	-	3/4	3/4	3/4	-	-	-	-	-	-	-
Starting Torque at Full Load (in.lb)	Standard	10.5	50	180	110	220	500	350	800	700	925	2700
	Option 1	5	25	80	50	90	206	175	400	325	475	1500
	Option 2	-	30	135	68	-	-	-	-	-	-	-
Running Torque at Full Load (in.lb)	Standard	9.5	45	160	100	180	410	300	700	650	825	2200
	Option 1	4.5	20	70	45	80	183	150	290	300	425	1200
	Option 2	-	25	105	60	-	-	-	-	-	-	-
Efficiency Rating	Standard	0.67	0.59	0.66	0.66	0.70	0.65	0.63	0.57	0.61	0.60	0.68
	Option 1	0.35	0.33	0.38	0.37	0.39	0.36	0.42	0.46	0.44	0.39	0.41
	Option 2	-	0.53	0.51	0.55	-	-	-	-	-	-	-
Weight with Baise Raise of 6" (lbs)		2.75	20	20	21	40	40	50	50	115	235	520
Weight for each additional 1" Raise (lbs)		0.1	0.33	0.33	0.42	0.85	0.85	0.85	0.85	1.5	2.9	5
Hold Back Torque at Rated Load (ft.lb)	Standard	1	2	2	7	8	8	11	11	24	24	92
	Option 1	0.5	0.5	0.5	0.5	0.5	0.5	0.5	0.5	2	2	33
	Option 2	-	1	1	2	-	-	-	-	-	-	-

* Dimensions same as model M2802 and M28021.

Note Lifting screws listed above are not keyed. Must be held to prevent rotation. Hold Back Torque is restraining torque at the worm shaft to keep load from running down. Lifting torques are proportional to load, down to 25% of rated load.

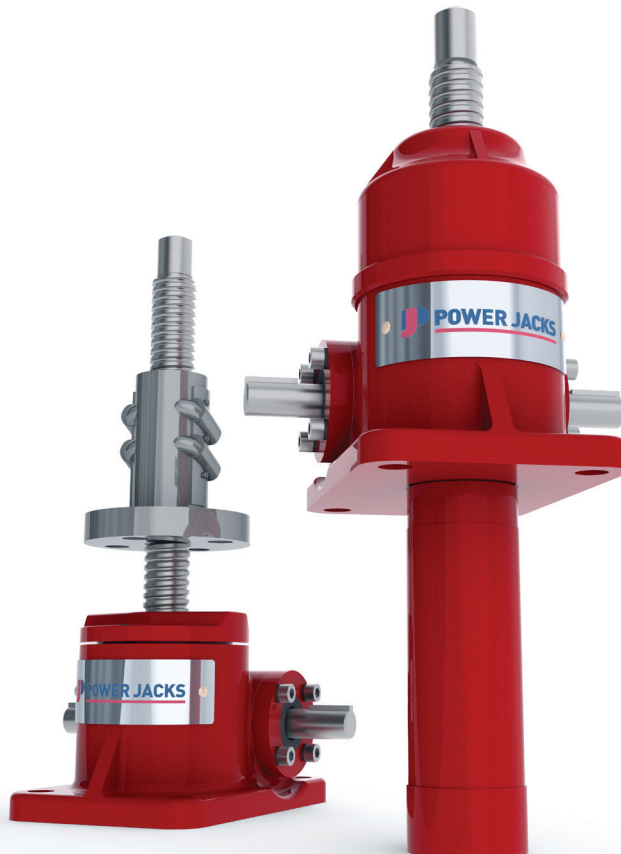

Life Expectancy of Inch Ball Screw and Ball Nut

Predicting screw and nut life lets you forecast necessary replacement, saving time and money. It also permits selection of the most economical screw size.

Use caution when installing the ball screw. The life expectancy listed below may be greatly reduced if ball screws are subjected to misalignment, shock loads, side thrust, environmental contamination or lack of lubrication maintenance.

It is possible to estimate the minimum life of the ball screw and nut only. Because of the many variable operating conditions, we can not accurately predict the life of the worm and gear set in the 2800 and 9800 Series screw jacks. Consult Power Jacks Ltd for advice.

Life in Thousands of Inches Travelled

Model	M2863I	M2802&M9802	M2802I&M9802I	M28003	M2805	M2805I	M2810	M2810I	M2820	M2825	M2860
Capacity (Short Tons)	0.5	2	2	3	5	5	10	10	20	25	50
100% Full Load	400	50	125	250	1000	500	100	50	150	700	600
75% Full Load	1200	150	300	650	2500	1000	350	150	350	2000	1500
50% Full Load or Less	3500	500	1000	2200	9000	4000	1000	500	1200	6000	5000

Note 5 Ton and 10 Ton models use the same screw and nut.

Imperial Ball Nut Return Tube Dimensions

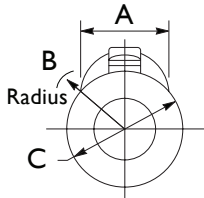

Model	M2863I	M2802&M9802	M2802I&M9802I	M28003	M2805 & M2810	M2805I & M2810I	M2820	M2825	M2860
Lead	0.200	0.250	1.000	0.413	0.474	1.00	0.500	0.660	1.000
A	0.822	1.104	1.104	1.587	1.981	1.718	2.561	3.349	4.029
B (Radius)	0.797	1.194	1.194	1.386	1.69	1.72	2.272	3.076	3.756
C	1 Sq.	1.5 Sq.	1.5 Sq.	2.125 Dia.	2.625 Dia.	2.625 Dia.	3.75 Dia.	4.751 Dia.	5.88 Dia.

Note: All dimensions in inches.



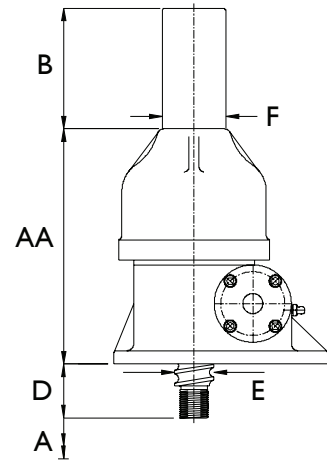
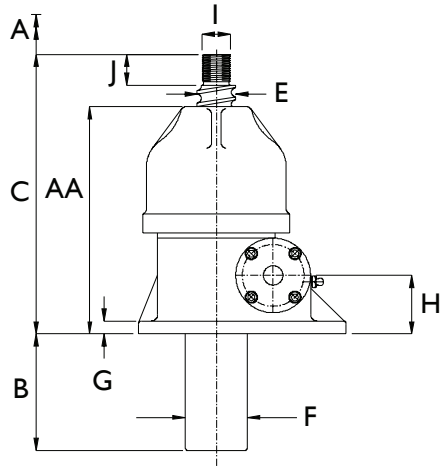

Plan View

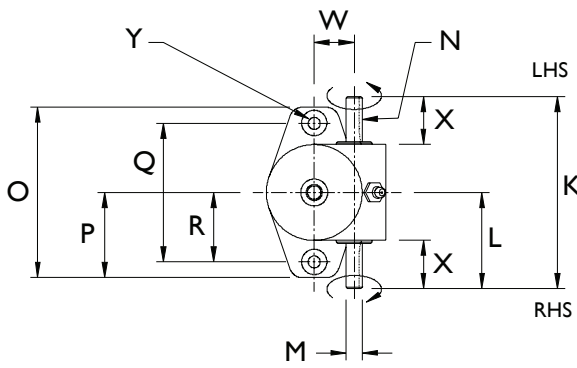

Model:
M28631

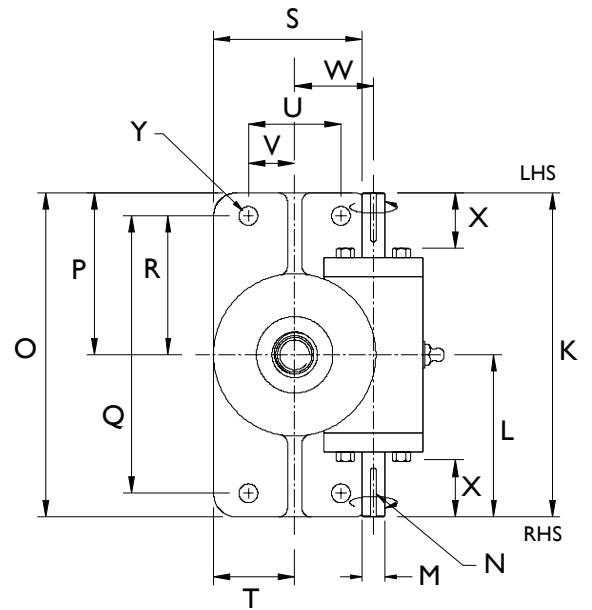

Models:
M2802, M28021, M28003, M2860.

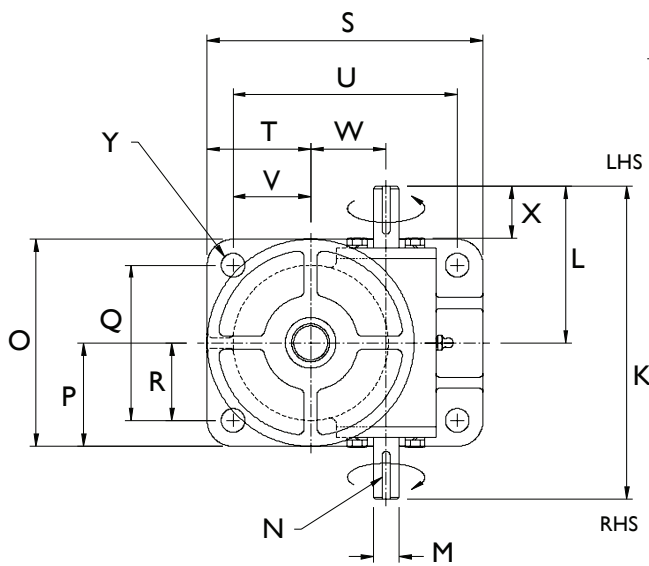

Models:
M9802, M98021, M2805, M28051, M2810,
M28101, M2820, M2825.

Note LHS = Left Hand Side
RHS = Right Hand Side

Model Upright	M28631	M2802 & M28021	M9802 & M98021	M28003	M280 & M2801	M2810 & M28101	M2820	M2825	M2860
Inverted	M28630	M2801 & M28011	M9801 & M98011	M28002	M280 & M2801	M2809 & M28091	M2819	M2824	M2859
Capacity (Short Tons)	0.5	2	2	3	5	10	20	25	50
A	Raise As Required								
B	A+1	A + 0.75	A + 0.75	A + 0.75	A + 2	A + 1	A + 0.75	A + 2	A + 2.75
C	5	7.5	7.5	9.25	10.75	10 3/8	16.5	19.75	25 3/8
D	1	1 3/8	1 3/8	1 3/8	1 3/8	1.5	2.75	3 1/8	3 5/8
E	5/8	1	1	1 11/64	1.5	1.5	2.25	3	4
F	1 1/16	1 21/32	1 21/32	1 21/32	2 3/8	2 7/8	3.5	4.5	5 9/16
G	5/16	0.5	0.5	0.5	0.5	0.5	0.75	1	1.25
H	1 ± 0.003	1.75 ± 0.005	1.75 ± 0.005	1.75 ± 0.005	2.25 ± 0.005	2.25 ± 0.005	3.25 ± 0.005	4 ± 0.005	4.75 ± 0.005
I	3/8-24UNF-2A	3/4-16UNF-2A	3/4-16UNF-2A	3/4-16UNF-2A	1-14UNS-2A	1-14UNS-2A	1.75-12UN-2A	2.25-12UN-2A	3.25-12UN-2A
J	0.75	1 1/8	1 1/8	1 1/8	1 1/8	1 1/8	2.25	2.25	2.75
K	4.5	7	7	7	9	11	11	14	22
L	2.25	3.5	3.5	3.5	4.5	5.5	5.5	7	11
M	0.375 / 0.373	0.500 / 0.498	0.500 / 0.498	0.625 / 0.623	0.749 / 0.747	0.999 / 0.997	1.000 / 0.998	1.375 / 1.373	1.500 / 1.498
N	1/8 X 1/6 X 3/4	1/8 X 1/16 X 1	1/8 X 1/16 X 1	3/16 X 3/32 X 1	3/16X3/32X1.25	1/4 X 1.8 X 1.5	1/4 X 1/8 X 1.5	5/16 X 5/32 X 2	3/8 X 3/16 X 2.25
O	4	7	4 1/8	7	6	7.5	8.25	10.25	19.75
P	2	3.5	2 1/16	3.5	3	3.75	4 1/8	5 1/8	9 7/8
Q	3.25	6	3 1/8	6	4.5	5.75	6	7.5	16
R	1 5/8	3	1 9/16	3	2.25	2 7/8	3	3.75	8
S	-	3.5	6 1/4	3.5	8	8.75	11	13.75	9.75
T	-	1.75	2 7/16	1.75	3	2 7/8	4 1/8	5 1/8	4 7/8
U	-	2	5 1/4	2	6.5	7	8.75	11	6
V	-	1	1 15/16	1	2.25	2	3	3.75	3
W	0.941 / 0.938	1.705 / 1.702	1.705 / 1.702	1.706 / 1.701	2.190 / 2.188	2.601 / 2.598	2.601 / 2.598	3.755 / 3.750	5.316 / 5.313
X	1 1/8	1 1/8	1 1/8	1 1/8	1.5	1.8	1.5	2 5/16	4 7/16
Y	9/32	13/32	13/32	13/32	11/16	13 / 16	1 1/8	1 3/8	1 7/8
AA	4	5 5/8	5 5/8	7.25	8.75	8 3/8	13	16.75	21 3/8

Standard M-Series Translating Ball Screw Ends

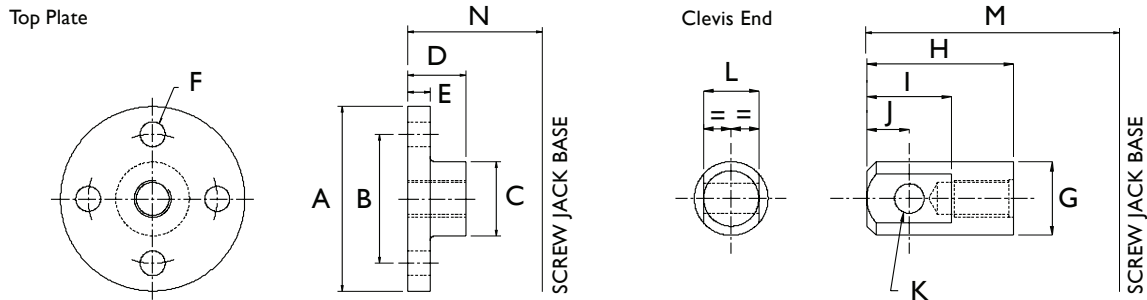

Model	M28631	M2802 & M28021	M2805 & M28051	M28003	M2805 & M28051	M2810 & M28101	M2820	M2825	M2860	
A	Ø 2.25	Ø 4.25	Ø 4.25	Ø 4.25	Ø 5	Ø 5.75	Ø 7	Ø 8.5	Ø 13	
B	PCD 1.5	PCD 3	PCD 3	PCD 3	PCD 3.5	PCD 4.125	PCD 5	PCD 6	PCD 10	
C	Ø 0.75	Ø 1.5	Ø 1.5	Ø 1.5	Ø 1.75	Ø 1.75	Ø 2.625	Ø 3.5	Ø 4.5	
D	1 ^{13/16}	1 1 ^{13/16}	1 1 ^{13/16}	1 1 ^{13/16}	1.25	1.375	2 5 ^{1/16}	2 5 ^{1/16}	2 1 ^{13/16}	
E	5/16	7/16	7/16	7/16	0.625	0.75	1	1	1.375	
F	Ø 9/32	Ø 1 ^{13/32}	Ø 1 ^{13/32}	Ø 1 ^{13/32}	Ø 1 ^{11/16}	Ø 1 ^{13/16}	Ø 1 ^{13/16}	Ø 1 1 ^{1/16}	Ø 1.5	
G	Ø 0.75	Ø 1.5	Ø 1.5	Ø 1.5	Ø 1.75	Ø 2	Ø 2.625	Ø 3.5	Ø 5	
H	2.25	3	3	3	4.125	4.125	6.25	8.25	9.125	
I	1	1.5	1.5	1.5	2.5	2.5	3	5	5.25	
J	0.5	0.75	0.75	0.75	1.25	1.25	1.5	2.5	2.625	
K	Ø 5/16	Ø 1/2	Ø 1/2	Ø 1/2	Ø 3/4	Ø 1	Ø 1 1/4	Ø 1 1/2	Ø 2	
L	0.5	1	1	1	1.25	1.5	1.75	2.75	3.75	
M	Upright	6	8 5/8	8 5/8	10 3/8	12 1/2	12 1/8	19	23 1/4	29 1/8
	Inverted	2	2 1/2	2 1/2	2 1/2	3 1/8	3 1/4	5 1/4	6 5/8	7 3/8
N	Upright	5	7 1/2	7 1/2	9 5/16	10 3/4	16 1/2	19 3/4	25 7/16	
	Inverted	1 1/16	1 7/16	1 7/16	1 7/16	1 9/16	2 13/16	3 3/16	3 11/16	

Note For all other dimensions and performance data refer to translating screw models All dimensions in inches (1" = 25.4 mm).

Upright Rotating Ball Screw Jack

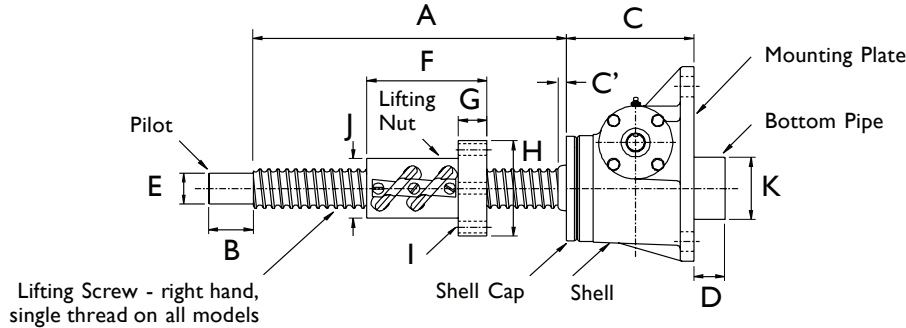

Model	UM 28632	KUM 2803	KUM 28031*	UM 9803	UM 98031*	KUM 28004	KUM 2806	KUM 28061*	UM 2811	UM 28111*	UM 2821	UM 2826	UM 2861*	
Capacity (Short Tons)	0.25	2	2	2	2	3	5	5	10	10	20	25	50	
A	Raise + 2	Raise + 3 1/16	Raise + 3 1/16	Raise + 3 1/16	Raise + 3 1/16	Raise + 3.75	Raise + 4 5/8	Raise + 4	Raise + 6	Raise + 5	Raise + 8	Raise + 10	Raise + 15	
B	0.625	1.125	1.125	1.125	1.125	1.125	1	1	1	1	2.5	2.25	3.25	
C	2 3/8	4 1/16	4 1/16	4 1/16	4 1/16	4 1/16	5 1/4	5 1/4	5 5/8	5 5/8	7 1/8	8 7/8	10 7/8	
C'	0	0	0	0	0	7/16	0	0	0	0	1	1 5/8	1 1/8	
D	0	0	0	0	0	0	0	0	0	0	0	0	0.75	
E	Dia.	0.437	0.750	0.750	0.750	0.750	1.000	1.000	1.000	1.000	1.750	2.250	3.250	
		0.435	0.748	0.748	0.748	0.748	0.748	0.998	0.998	0.998	0.998	1.748	2.248	3.248
F	1.75	2 3/8	3 1/32	2 3/8	3 1/32	3.395	4.33	3.65	4.33	3.65	6.706	9.395	12.625	
G	0.53125	0.630	0.630	0.630	0.630	0.832	0.895	1.02	0.895	1.02	1.582	2.02	2.02	
H	Dia.	2.625	3.25	3.25	3.25	3.25	4.2	4 15/16	4 15/16	4 15/16	5.375	7.375	9.75	
		Holes	4	4	4	4	4	4	4	4	4	6	8	6
I	Dia.	17/64	17/64	17/64	17/64	17/64	25/64	17/32	17/32	17/32	21/32	25/32	1 1/32	
		P.C.D	2 3/32	2.75	2.75	2.75	2.75	3 7/16	4 1/16	4 1/8	4 1/16	4 1/8	4.375	6.25
J	Dia.	1 SQR.	1.5 SQR.	1.5 SQR.	1.5 SQR.	1.5 SQR.	2.125	2.625	2.25 SQR.	2.625	2.25 SQR.	3.375	4.751	5.88
K	Dia.	0	0	0	0	0	0	0	0	0	0	0	5.5625	

* 1" Lead Screw Models.

Inverted Rotating Ball Screw Jack

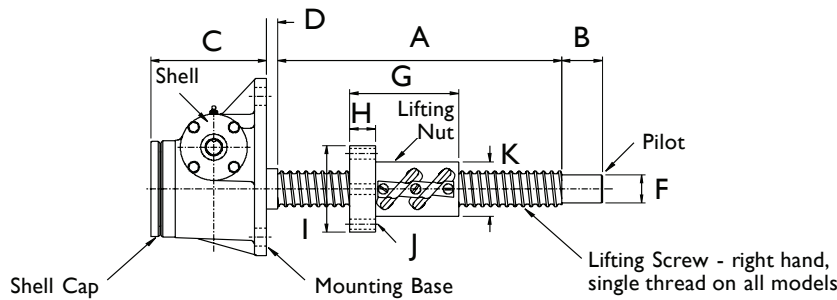

Model	DM 28632	KDM 2803	KDM 28031*	KDM 9803	KDM 98031*	KDM 28004	KDM 28006	KDM 28061*	KDM 2811	KDM 28111*	KDM 2821	KDM 2826	KDM 2861*	
Capacity (Short Tons)	0.25	2	2	2	2	3	5	5	10	10	20	25	50	
A	Raise + 2 3/8	Raise + 3	Raise + 3 5/8	Raise + 3 1/6	Raise + 3 5/8	Raise + 3.75	Raise + 4 5/8	Raise + 4	Raise + 6	Raise + 5	Raise + 8	Raise + 10	Raise + 15	
B	0.625	1.125	1.125	1.125	1.125	1.125	1	1	1	1	2.5	2.25	3.25	
C	2.375	3.75	3.75	3.75	3.75	3.75	5.25	5.25	5	5	7.125	8.875	11	
D	0	0.625	0.625	0.625	0.625	1	0.75	0.75	1.125	1.125	1.625	2.5	2.5	
F	Dia.	0.437	0.750	0.750	0.750	0.750	1.000	1.000	1.000	1.000	1.750	2.250	3.250	
		0.435	0.748	0.748	0.748	0.748	0.748	0.998	0.998	0.998	0.998	1.748	2.248	3.248
G	1.75	2 3/8	3 1/32	2 3/8	3 1/32	3.395	4.33	3.65	4.33	3.65	6.706	9.395	12.625	
H	0.53125	0.630	0.630	0.630	0.630	0.832	0.895	1.02	0.895	1.02	1.582	2.02	2.02	
I	Dia.	2.625	3.25	3.25	3.25	3.25	4.2	4 15/16	4 15/16	4 15/16	4 15/16	5.375	7.375	9.75
		Holes	4	4	4	4	4	4	4	4	4	6	8	6
J	Dia.	17/64	17/64	17/64	17/64	17/64	25/64	17/32	17/32	17/32	21/32	25/32	1 1/32	
		P.C.D	2 3/32	2.75	2.75	2.75	2.75	3 7/16	4 1/16	4 1/8	4 1/16	4 1/8	4.375	6.25
K	Dia.	1 SQR.	1.5 SQR.	1.5 SQR.	1.5 SQR.	1.5 SQR.	2.125	2.625	2.25 SQR.	2.625	2.25 SQR.	3.375	4.751	5.88

Note: Dimensions subject to change without notice.

* 1" Lead Screw Models.

Note: For other performance and dimension information refer to translating ball screw jacks.

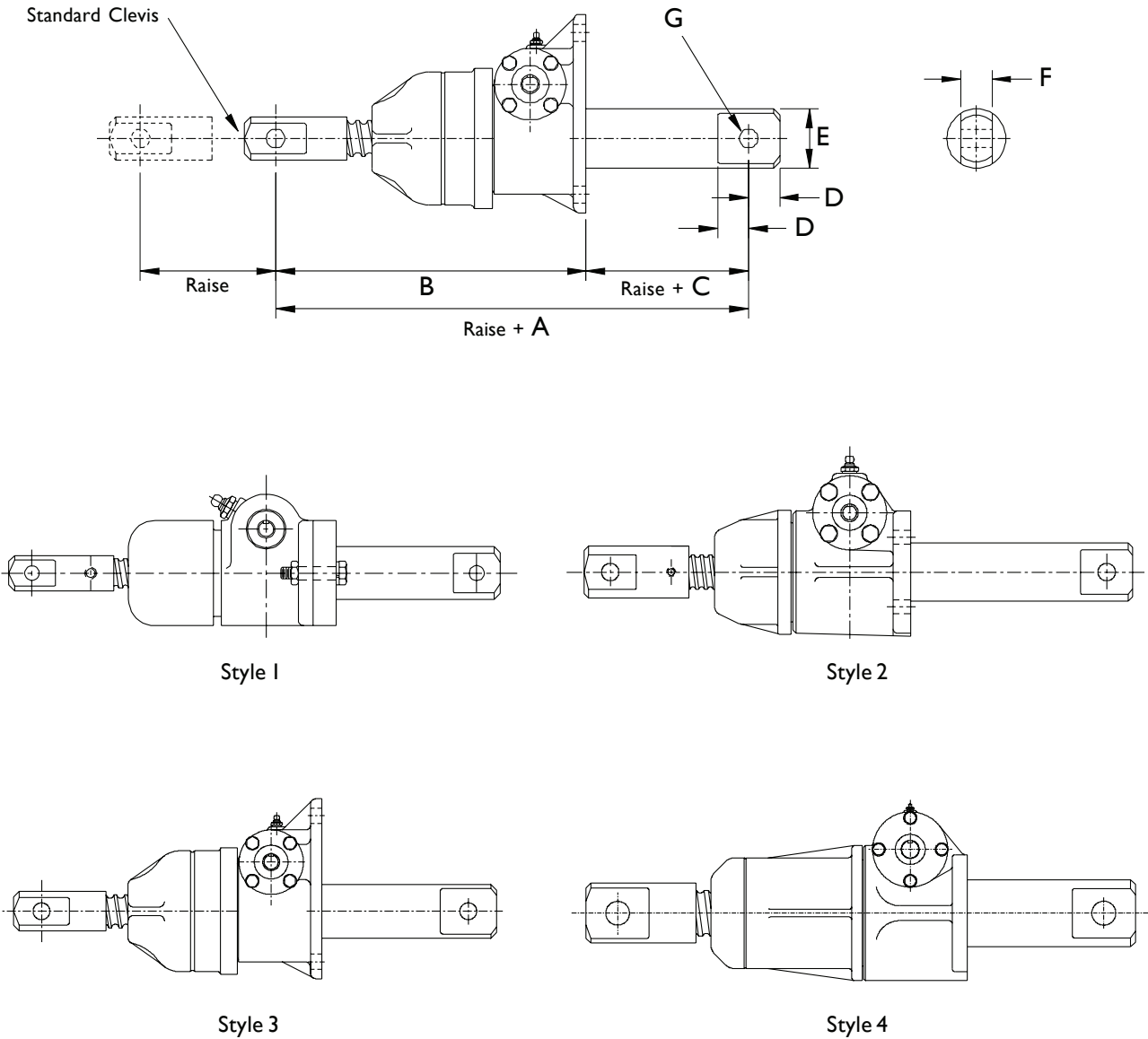

Model	CCM 28631	CCM 2802 & 28021	CCM 9802 & 98021	CCM 28003	CCM 2805 & 28051	CCM 2810 & 28101	CCM 2820	CCM 2825	CCM 2860		
Capacity (Short Tons)	0.5	2	2	3	5	10	20	25	50		
Style	1	2	3	2	3	3	3	3	4		
A	8.25	11.125	11.125	12.875	16.25	16	23	30.25	37.125		
B	6	8.625	8.625	10.375	12.5	12.125	19	23.25	29.125		
C	2.25	2.5	2.5	2.5	3.75	3.875	4	7	8		
D	0.5	0.75	0.75	0.75	1.25	1.25	1.5	2.5	2.625		
E	1.125	1.625	1.625	1.75	2.375	2.875	3.5	4.5	5.5625		
F	0.75	1	1	1	1.25	1.5	1.75	2.75	3.75		
G	Diameter		5/16	0.5	0.5	0.5	0.75	1	1.25	1.5	2
Max. Allowable Raise in Compression at Load (lb)	Raise	7.875	15	15	15.5	20.375	20.5	34.5	47	63.5	
	Load	1000	3800	3800	4200	7400	7400	20000	35000	61000	
Max Raise At Rated Load (Compression)		7.875	14.5	14.5	11.5	16	9.5	21.5	37	47.5	

Note 1. All dimensions in inches unless otherwise stated (1" = 25.4 mm).
 2. Dimensions subject to change without notice.

Features

- Protects the screw from dust and dirt.
- Helps maintain the proper lubrication.
- Guards against moisture and corrosive contaminants.
- Boots are made of neoprene-coated nylon with sewn construction. Other materials are available for applications involving high temperatures, highly corrosive atmospheres and other special conditions.

Boot Installation Data

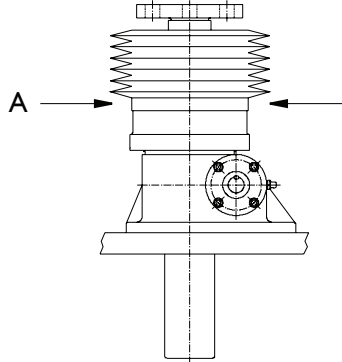

Capacity	1000 lb	2 Ton	3 Ton	5 Ton
Shell Cap Diameter "A"	2.25	3.5	3.5	5.375

Capacity	10 Ton	20 Ton	25 Ton	50 Ton
Shell Cap Diameter "A"	4.5	7	8.875	9.5

Note For horizontal installation exceeding 18" of travel, internal boot guides are recommended.

Upright Inch Ball Screw Jacks with Bellows Boots

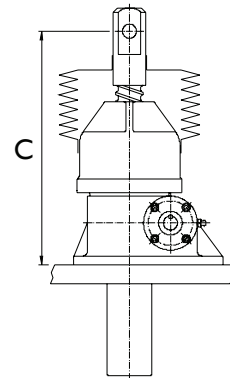
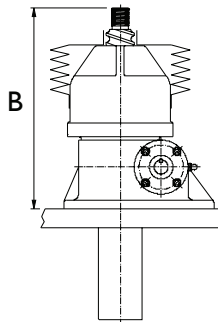
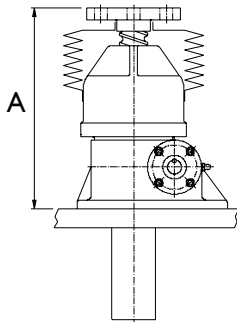

Model No.	Boot O.D.	Raise							
		1-12"	18"	24"	30"	36"	48"	60"	72"
M28631	4.50	5.000	-	-	-	-	-	-	-
M2802	6.63	7.500	7.500	7.500	8.500	-	-	-	-
M28021	6.63	7.500	7.500	7.500	8.500	-	-	-	-
M9802	6.63	7.500	7.500	7.500	8.500	-	-	-	-
M98021	6.63	7.500	7.500	7.500	8.500	-	-	-	-
M28003	6.63	9.250	9.250	9.250	10.250	10.250	11.250	-	-
M2805	7.50	10.750	10.750	10.750	12.500	12.500	13.750	-	-
M28051	7.50	10.750	10.750	10.750	12.500	12.500	13.750	-	-
M2810	7.00	10.375	10.375	10.375	11.625	11.625	12.875	-	-
M28101	7.00	10.375	10.375	10.375	11.625	11.625	12.875	-	-
M2820	9.00	16.500	16.500	16.500	16.500	16.500	18.500	20.500	21.500
M2825	11.00	19.750	19.750	19.750	19.750	19.750	21.250	22.750	24.250
M2860	12.00	25.375	25.375	25.375	25.375	25.375	26.375	27.375	28.375

- Note
1. (-) indicates "Not Applicable".
 2. For lengths of raise not detailed in the above table consult PowerJacks Ltd.
 3. All dimensions in inches (1" = 25.4 mm).
 4. Dimensions subject to change without notice.

Inverted Inch Ball Screw Jacks with Bellows Boots

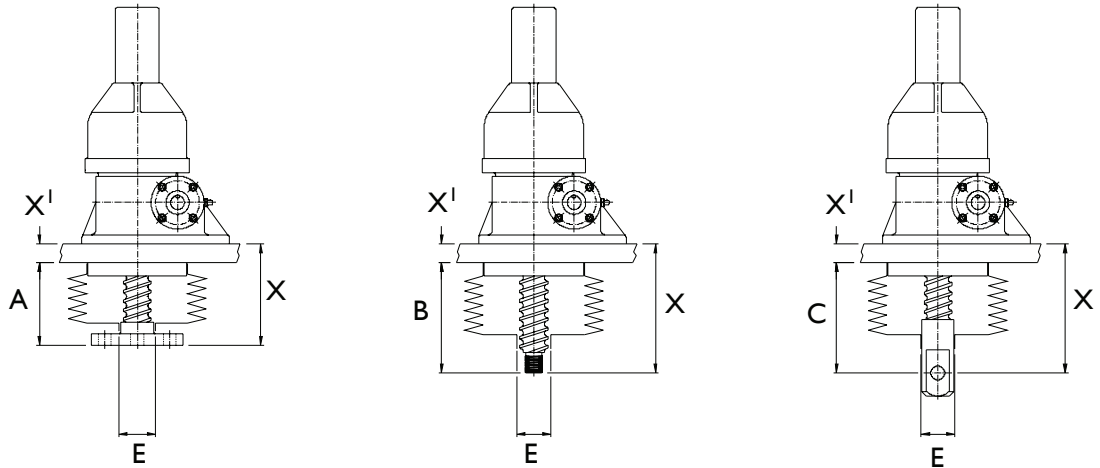

Finding minimum closed dimensions (X)

- Add your structure thickness X¹ to A, B, or C from the appropriate chart to find the minimum closed dimension.
- Other styles and sizes of boots can be supplied.
- In order to use a standard boot, make the mounting plate diameter the same as the shell cap diameter of the appropriate screw jack.
- When boots are required for rotating screw jacks consult Power Jacks Ltd.

Model No.	Raise (inches)												Std. Boot Collar Dia
	1"-6"			7"-12"			13"-18"			19"-24"			
	A	B	C	A	B	C	A	B	C	A	B	C	
M28630	2	2	2 3/4	2 3/8	2 3/8	3 1/4	2 3/4	2 3/4	3 3/4	3 1/4	3 1/4	4 1/4	.75
M2801 & M9801	4 3/16	4 5/8	5 1/4	4 3/16	4 5/8	5 1/4	4 3/16	4 5/8	5 1/4	4 3/16	4 5/8	5 1/4	1.5
M28002	4 3/16	4 5/8	5 1/4	4 3/16	4 5/8	5 1/4	4 3/16	4 5/8	5 1/4	4 3/16	4 5/8	5 1/4	1.5
M2804	4 3/16	5 1/8	6 1/8	4 5/8	5 1/8	6 1/8	4 5/8	5 1/8	6 1/8	4 5/8	5 1/8	6 1/8	1.75
M2809	4 3/4	5 1/8	6 1/8	4 3/4	5 1/8	6 1/8	4 3/4	5 1/8	6 1/8	4 3/4	5 1/8	6 1/8	1.5
M2819	6 3/4	8	9 3/4	6 3/4	8	9 3/4	6 3/4	8	9 3/4	6 3/4	8	9 3/4	2.615
M2824	5 1/2	6 3/4	9 1/2	5 1/2	6 3/4	9 1/2	5 1/2	6 3/4	9 1/2	5 1/2	6 3/4	9 1/2	3.5
M2859	7 1/4	7 1/4	10 7/8	7 1/4	7 1/4	10 7/8	7 1/4	7 1/4	10 7/8	7 1/4	7 1/4	10 7/8	4.5

Mounting Plate

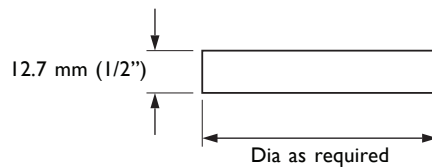

To be manufactured by installer

- Note
1. For lengths of raise not detailed in the above table consult Power Jacks Ltd.
 2. Dimensions subject to change without notice.
 4. All dimensions in inches

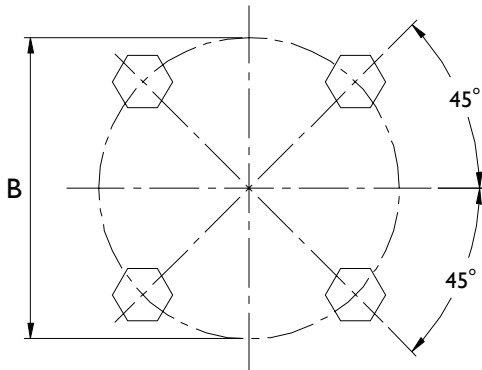

Model	'B' Bolt P.C.D (inch)	Bolt Information
M28631	-	No Flange Bolts
M2802 & M9802	1 11/16	1/4 - 20 x 3/4" Long
M28003	1 11/16	1/4 - 20 x 3/4" Long
M2805	2 3/8	5/16 - 18 x 3/4" Long
M2810	2 3/4	5/16 - 18 x 3/4" Long
M2820	3 1/2	3/8 - 16 x 1 1/4" Long
M2825	4 1/8	3/8 - 16 x 1 1/4" Long
M2860	5 1/4	5/8 - 11 x 1 1/2" Long

- Note
1. All dimensions in inches (1" = 25.4 mm).
 2. Dimensions subject to change without notice.

Motor Adaptors for M-Series Ball Screw Jacks

Dimensions and details are the same as for M-Series machine screw jacks.

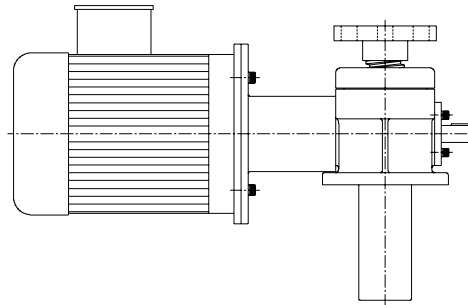

Rotary Limit Switch Adaptors for M-Series Ball Screw Jacks

Dimensions and details are the same as for M-Series machine screw jacks.

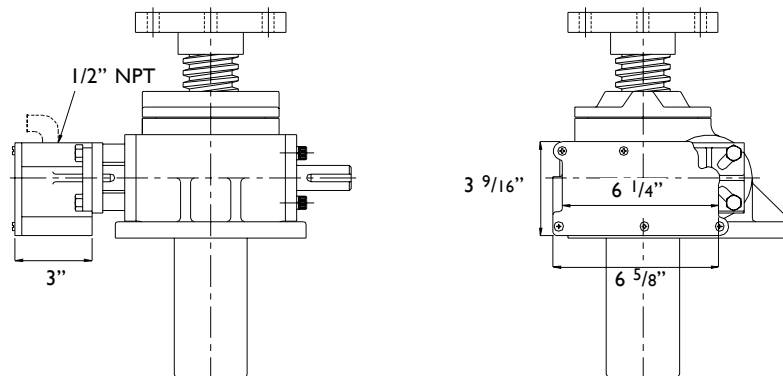

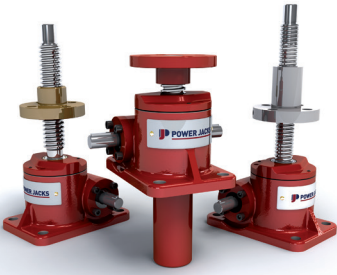

Screw Jacks

- E-Series Metric Machine Screw Jacks 5 - 2000kN
- E-Series Metric Stainless Steel Screw Jacks 10 - 1000kN
- E-Series Metric Ball Screw Jacks 10 - 500kN
- C-Series Metric Cubic Machine Screw Jacks 10 - 100kN
- S-Series Metric High Performance Screw Jacks 25 - 200kN
- Special screw jack designs available up to 35000kN

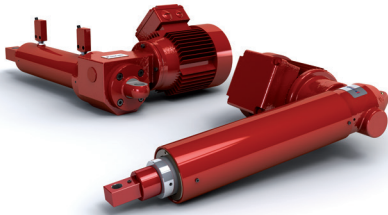

EMA Linear Actuators

- Machine Screw & Ball Screw
- Low load, Medium Duty, High Speed
- Dynamic Load Ratings up to 10kN
- Linear Speeds up to 5500 mm/min
- 3-phase AC, 1-phase AC, and DC types
- Special Designs Available

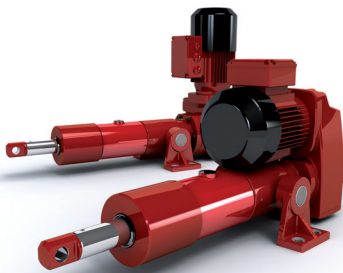

Rolaram Linear Actuators

- Ball Screw & Roller Screw
- High load, High Duty, High Speed
- Very High Accuracy
- Dynamic Load Ratings up to 400kN
- Linear Speeds up to 7000 mm/min
- 3-phase AC, 1-phase AC, and DC types
- Special Designs Available

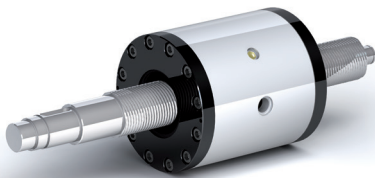

Spiracon Roller Screws

- High Dynamic Loads up to 1200kN
- High Efficiency
- High Positional Accuracy
- Long Life
- Low Maintenance
- Low Noise
- Robust Design for Harsh Environments
- Special Designs Available



Neeter Drive Bevel Gearboxes

- 2-way, 3-way and 4-way Designs
- Solid Shaft & Hollow Shaft
- Motor Adaptors
- Gear Ratios 1:1, 1.5:1, 2:1, 3:1 and 4:1
- Torque Ratings up to 3000Nm
- Special Gear Ratios and Designs Available



Lifting & Positioning Solutions

Power Jacks are specialist industrial engineers providing design, manufacturing and services of quality industrial lifting, positioning and load monitoring equipment. Our products are supplied globally across many sectors including Industrial Automation, Energy, Transport, Defence and Civil.

Power Jacks Ltd
Balmacassie Commercial Park
Ellon, AB41 8BX
Scotland (UK)
Tel: +44 (0)1358 285100

www.powerjacks.com
sales@powerjacks.com

PJ-SJB-M-EN-01

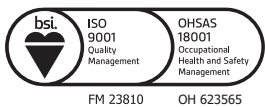

All information in this document is subject to change without notice. All rights reserved by Power Jacks Limited. May not be copied in whole or in part. ©Power Jacks Limited 2015, Aberdeenshire, Scotland, United Kingdom.

View Profile 

 Find us on
Facebook