

# POWERJACKS

PRECISION ACTUATION

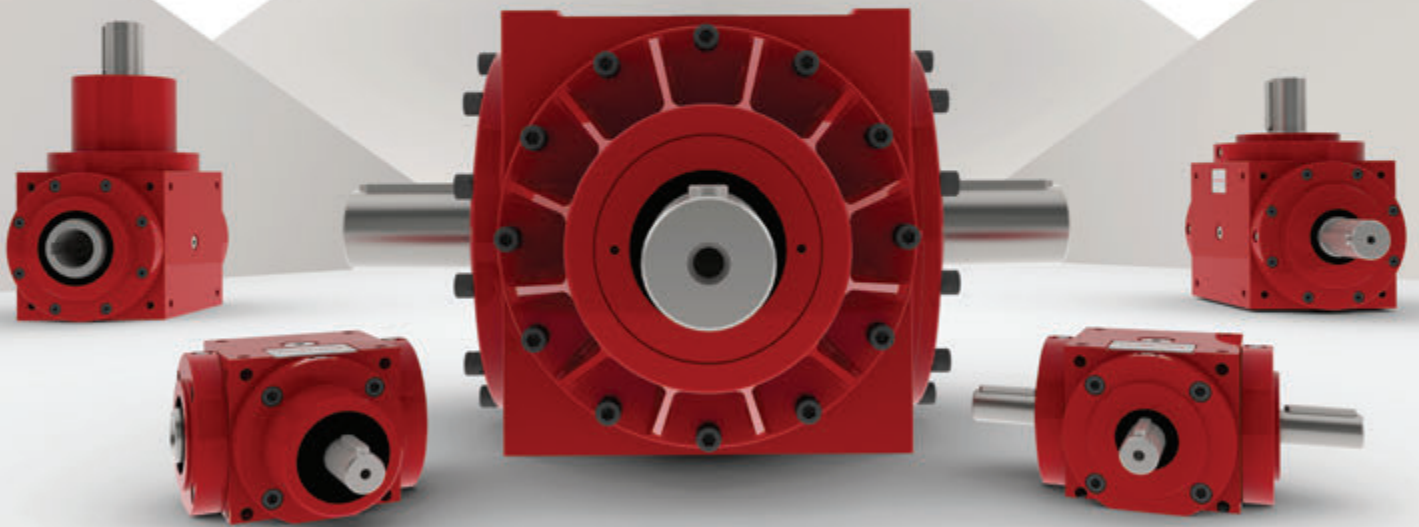

**RANGE-C BEVEL GEARBOXES**

## POWERJACKS

Best engineered  
solution for precision  
linear actuation,  
power transmission  
& jacking systems.



OUR EXPERTISE HAS BEEN BUILT ON A HISTORY OF MORE THAN 100 YEARS OF ENGINEERING, CRAFTSMANSHIP, VISIONARY DESIGN, QUALITY MANUFACTURE AND CUSTOMER CARE.

Power Jacks is a manufacturing/engineering company specialising in the design and manufacture of actuation, lifting and positioning solutions for applications in Industrial Automation, Energy, Defence, Medical, Transport, and the Civil Engineering sectors.

Headquartered near Aberdeen in the UK, the company is the UK's largest screw jack manufacturing facility, that uses the latest engineering technologies to deliver quality products (ISO 9001) that offer reliability, performance and economy.

Power Jacks deliver this high quality service in a safe (ISO 45001) and environmentally friendly (ISO 14001) working environment thanks to the highly trained, flexible and motivated teams that work throughout the business driving the company to higher levels of performance.

We know our customers demand our engineering expertise to help find a solution for their applications. We take pride in designing and delivering the best solution using standard or special designs that help improve your business.

Our Vision is to become the partner of choice for our products globally

Our Mission is to provide high quality lifting & positioning solutions.

# Global Reach

Power Jacks has local representation in 26 countries and supplies its products to more than 80 countries worldwide.



A global reach with a local service as we work closely with our customers to ensure the best solution for all their Electro-Mechanical solution applications.

- Headquarters & Factory
- Local Power Jacks Sales Offices
- Local Representative

**1. Bevel Gearbox Range**

Features .....	7
Basic Range Overview .....	10
Product Code .....	11
How to Select a Bevel Gearbox .....	14
Performance .....	16
Torque and Power Rating .....	17
Load Factors .....	18
Permissible Shaft Loading .....	20
Shaft & Gear Configurations .....	21
Bevel Gearbox Range-C35 - Ratio 1:1 & 1.5:1.....	22
Bevel Gearbox Range-C35 - Ratio 2:1 & above.....	24
Bevel Gearbox Range-C35 - Hollow Shaft - All Ratios .....	26
Bevel Gearbox Range-C37 - Ratio 1:1 & 1.5:1.....	28
Bevel Gearbox Range-C37 - Ratio 2:1 & above.....	30
Bevel Gearbox Range-C37 - Hollow Shaft - All Ratios .....	32
Bevel Gearbox Range-C38 - Ratio 1:1 & 1.5:1.....	34
Bevel Gearbox Range-C38 - Ratio 2:1 & above.....	36
Bevel Gearbox Range-C38 - Hollow Shaft - All Ratios .....	38
Bevel Gearbox Range-C39 - Ratio 1:1 & 1.5:1.....	40
Bevel Gearbox Range-C39 - Ratio 2:1 & above.....	42
Bevel Gearbox Range-C39 - Hollow Shaft - All Ratios .....	44
Bevel Gearbox Range-C40 - Ratio 1:1 & 1.5:1.....	46
Bevel Gearbox Range-C40 - Ratio 2:1 & above.....	48
Bevel Gearbox Range-C40 - Hollow Shaft - All Ratios .....	50
Bevel Gearbox Range-N42 - Ratio 1:1 & 1.5:1 .....	52
Bevel Gearbox Range-N42 - Ratio 2:1 & above.....	54
Bevel Gearbox Range-N42 - Hollow Shaft - All Ratios .....	56
Motors Adapters .....	58
Optional Features .....	59
Subsea Gearbox .....	60
Custom Applications.....	61

## Note:

- 1 - All design subject to change without notice.
- 2 - All colours for illustrative purposes only.

# NEED HELP SELECTING A GEARBOX? THEN TRY OUR PRODUCT SELECTOR

Just enter your application details and the Product Selector will recommend a suitable product with a calculation summary and links to the associated CAD and Data Sheets. An ideal tool if you are not familiar with the products or need answers fast.

**Engineering: Product Selector**

If you are not sure how to select a product then use our automated selection tool which combines the knowledge of our experienced engineers to... engineering assistant (AET) from anywhere in the world.

Overview

Enter details below to find a product that meets your requirements.

**Enter Application Data**

**Get Recommended Product with**

- CAD
- Data Sheets

**Engineering: Product Selector**

If you are not sure how to select a product then use our automated selection tool which combines the knowledge of our experienced engineers to... engineering assistant (AET) from anywhere in the world.

Overview

Part Number: R37030-03A05-000-0000-00000

30 30

Download PDF Exam Sheet  
Download 2D/3D CAD Files  
Add to Shopping Cart

Input Speed (rpm)	Output Speed (rpm)	Input Torque (Nm)	Output Torque (Nm)	Input Power (kW)	Output Power (kW)	Efficiency (%)	Shaft Type	Shaft Size (mm)	Shaft Material	Shaft Finish	Shaft Coating	Shaft Protection	Shaft Lubrication	Shaft Sealing	Shaft Mounting	Shaft Alignment	Shaft Vibration	Shaft Noise	Shaft Temperature	Shaft Humidity	Shaft Dust	Shaft Contamination	
1500	750	85	85.7	0.175	0.17	100	Solid	16	Aluminum	Black Oxide	None	None	None	None	None	None	None	None	None	None	None	None	None

Back New Product

[www.powerjacks.com/portal](http://www.powerjacks.com/portal)

Bevel Gearbox Range-C

1

## Range-C Bevel Gearboxes

# COMPACT & VERSATILE SPIRAL BEVEL GEARBOXES



# Introducing the Range-C bevel gearbox range from Power Jacks, a compact and versatile design in a cubic housing.

Created by a team of experienced design engineers, the focus was to provide our customers with a compact bevel gearbox in a "cubic" housing that offers versatility in design. In addition to this, we wanted to design a bevel gearbox that had the perfect combination of excellent performance, a long lasting service life, durability and the flexibility to be engineered for the most demanding applications.

Perfect for industrial applications or the extreme such as subsea, defence or nuclear.

## Standard Gearbox

- 6 Gearbox Sizes  
35, 37, 38, 39, 40, 42\* Series  
\*42-Series in Range-N design only
- 16 Gearbox Configurations
- Gear Ratios:  
1:1, 1.5:1, 2:1, 3:1 and 4:1\*  
\*No 4:1 on 35-Series
- Special gear ratios available on request  
e.g. 1.25:1
- Power Ratings: 0.1 - 226 kW
- Torque Ratings: 15 Nm - 7000Nm
- Mounting Points on Every Gearbox Side (35 - 40 Series)

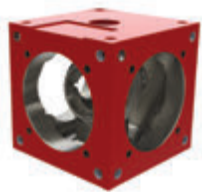

## Gearbox Housing

A rugged Cubic Compact design made from a highly durable SG Iron. This provides a strong housing that firmly and accurately holds the gear set in a reservoir of quality lubricant suited to the most industrial demands.



## Corrosion Protection

To suit all economic needs.

- Standard Industrial Paint Finish
- Arduous Environment Paint Finish
- Customer Specified Paint
- Plated Finish
- Stainless Steel

## Reliable Spiral Bevel Gear

With a proven design already used in millions of gearboxes, the Precision Spiral Bevel Gears with accurate gear mesh delivers high torque with smooth and quiet transmission.

## Superior Gear and Shaft Support

For gear ratios 1:1 and 1.5:1 where each gear has a bearing support on both sides. This gives optimum gear support and minimises bearing hub sizes for non-through shaft configurations.

## Shaft Configurations

- 2, 3 or 4-way
- Solid or hollow shaft
- Special configurations available
- Motor Adapter to bolt an IEC motor directly to the gearbox input
- Service life of 10,000 hours for all gearbox sizes
- Input Speed up to 3000 rpm maximum
- Breather / vents available for high speed designs





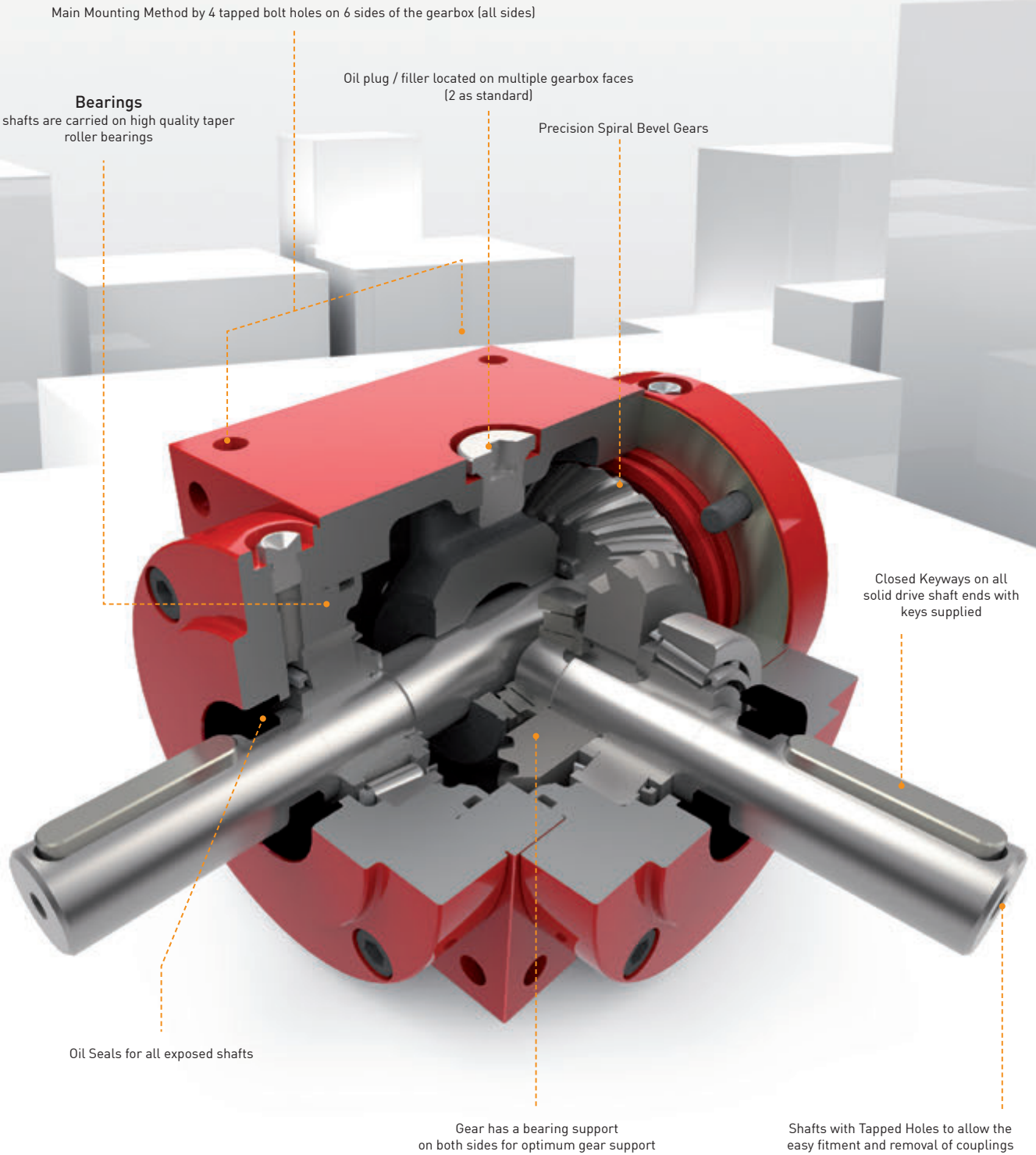

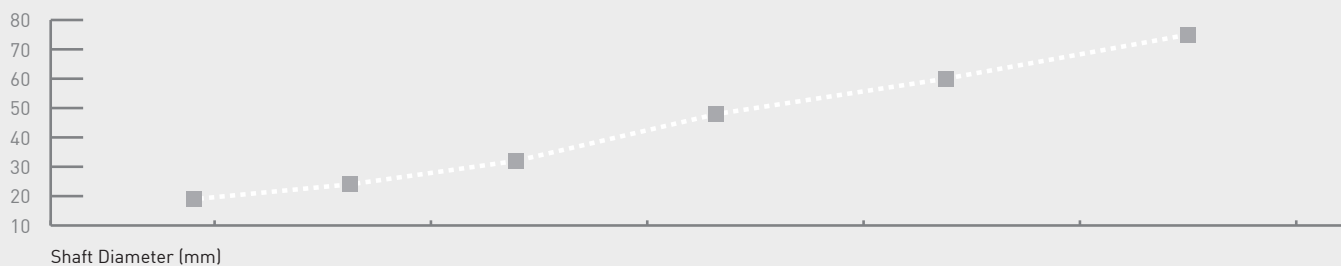
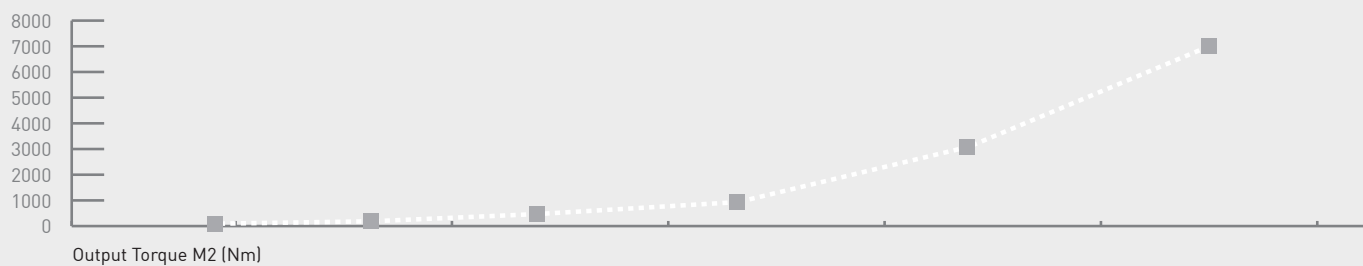
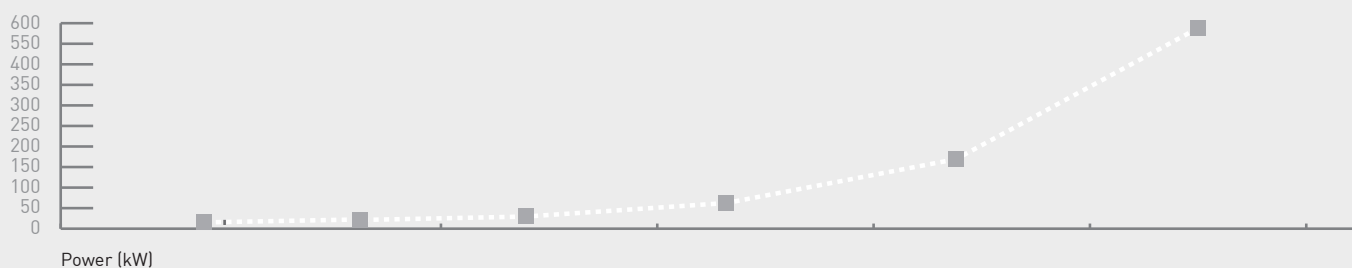
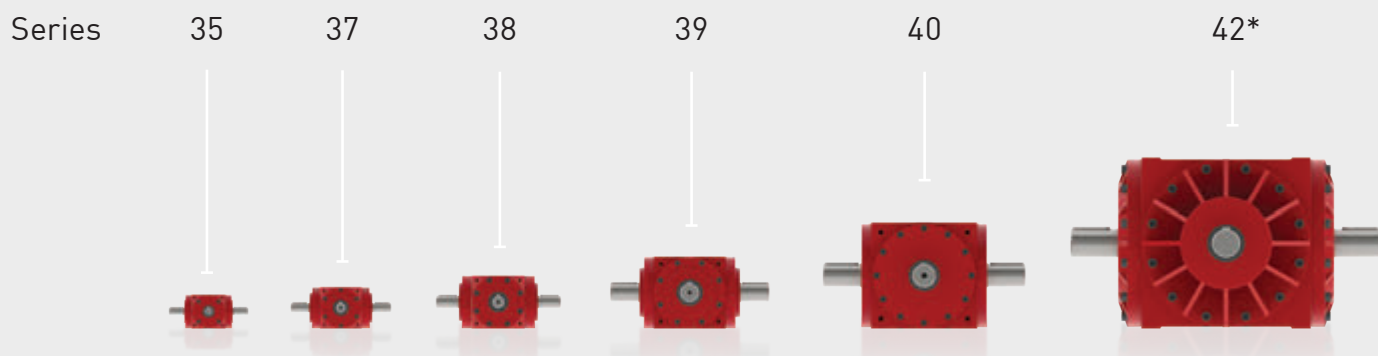

Based on Ratio 1:1, 3way solid shaft, Gear Unit Size  
 \*42 Series is Range-N design

Example

**C380S30-10M06-0000-0000-000000** C-Range, 38 Series, Standard, Solid Shaft, 4-Way, Standard Gear Configuration, 1:1 Gear Ratio, Metric Shaft (mm) - Spiral Bevel, Standard Material Shafts lubrication and paint.

1	2	3	4	5	6	7	8	9	10	11	12	13	14	15	16	17	18	19	20	21	22	23	24	25	26	27	28	29	30
C	3	8	0	S	3	0	-	1	0	M	0	6	-	0	0	1	0	-	0	0	0	0	0	-	0	0	0	0	0

**1 GROUP-1 - Bevel Gearbox Definition**

**2 GROUP-2 - Bevel Gearbox Features**

**3 GROUP-3 - Accessories**

**1 GROUP-1 - Bevel Gearbox Definition**

1-Bevel Gearbox Range	
C	Compact Cubic, Versatile Design with mounting bolt holes on every gearbox side
N	Ultra Compact, Versatile Design

2-3 - Gearbox Series	35	37	38	39	40	42
----------------------	----	----	----	----	----	----

4-Gearbox Type	
0	Standard
V	Vertical Shaft

5-Shaft Type	
S	Solid Shaft
H	Hollow Shaft

6-Shaft Number	
2	2-Way
3	3-Way
4	4-Way

7-Shaft Configuration	
0	Standard Gear Configuration
R	Reverse Gear Configuration

**8 - Character Space**

9-10 - Shaft Number	
10	1:1 Gear Ratio
15	1.5:1 Gear Ratio
20	2:1 Gear Ratio
30	3:1 Gear Ratio
40	4: 1 Gear Ratio

11-Gear & Shaft Design	
M	Metric Shaft (mm) - Spiral Bevel

12-13 - Design Revision	
XX	Internal Numbering System Only #1

**14 - Character Space**

**2 GROUP-2 - Bevel Gearbox Features**

15-Gearbox Housing Material	
0	Standard Material (SG Iron)
A	Aluminium
N	Nickel Plated SG Iron Housing
S	Stainless Steel Housing

16-Drive Shaft Design	
0	Standard Material
1	Reinforced Through Shaft for Higher Torque Transmission #10
C	Chrome Plated Drive Shafts
D	Chrome Plated & Reinforced for Through Shaft #10
N	Nickel Plated Drive Shafts
M	Nickel Plated & Reinforced for Through Shaft #10
S	Stainless Steel Drive Shafts
T	Stainless Steel & Reinforced for Through Shaft #10

17-Mounting	
0	Standard Range-N - 4 Tapped Holes - Side 5 & 6
1	Standard Range-C - ALL Sides Tapped Holes
5	4 Tapped Holes Side 5 Only
6	4 Tapped Holes Side 6 Only
A	Base Flange - Bolt-On - Side 5
B	Base Flange - Bolt-On - Side 6

18-Environment & Temperature Rating #8	
0	Standard
1	High Temperature
2	Low Temperature
N	Radiation Resistant
M	Radiation Resistant & Low Temperature
P	Radiation Resistant & High Temperature
R	Chemical Resistant
S	Chemical Resistant & Low Temperature
T	Chemical Resistant & High Temperature

## 19 - Character Space

20-Drive Shaft Keys - Side-1 (input)	
0	Standard (Closed Keyway) - also select if motor adapter
1	Open Keyway
2	Keyless #4

21-Drive Shaft Keys - Side-2	
0	Standard (Closed Keyway)
1	Open Keyway #2
2	Keyless #4

22-Drive Shaft Keys - Side-3	
0	Standard (Closed Keyway) - also select if hollow shaft #3
1	Open Keyway #2
2	Keyless #4

23-Drive Shaft Keys - Side-4	
0	Standard (Closed Keyway) - also select if hollow shaft #3
1	Open Keyway #2
2	Keyless #4

## 24 - Character Space

**3 GROUP-3 - Accessories**

25-Drive Type	
0	Standard (normal shafts, no extra features)
A	Motor Adapter, Input, B14
B	Motor Adapter, Input, B5
H	Hand Wheel - Side 1 (Input)
J	Hand Wheel - Side 2
K	Hand Wheel - Side 3
L	Hand Wheel - Side 4

26-Motor Frame Size	
0	Not Applicable
A	63
B	71
C	80
D	90
E	100
F	112
G	132
H	160
I	180
J	200

27-Drive Shaft Protective Cover	
0	None - Standard
1	Cover- Side 1 (Input)
2	Cover - Side 2
3	Cover - Side 3
4	Cover - Side 4
A	Cover - Side 2 & 3
B	Cover - Side 2 & 4
C	Cover - Side 3 & 4
R	Rotation Indicator (Visual) - Side 1
S	Rotation Indicator (Visual) - Side 2
T	Rotation Indicator (Visual) - Side 3
U	Rotation Indicator (Visual) - Side 4

28-Breather (Vent)	
0	None (Standard) #5
1	Breather fitted Side-1 (Input)
2	Breather fitted Side-2
3	Breather fitted Side-3
4	Breather fitted Side-4
5	Breather fitted Side-5
6	Breather fitted Side-6 #6
A	Breather 90deg Type fitted Side-1 (Input)
B	Breather 90deg Type fitted Side-2 #7
C	Breather 90deg Type fitted Side-3
D	Breather 90deg Type fitted Side-4
E	Breather 90deg Type fitted Side-5
F	Breather 90deg Type fitted Side-6

29-Lubricant #9	
0	Standard Oil (input speed >250 rpm)
1	Standard Grease (input speed < 250rpm)
2	No Lubricant
A	Food Grade Oil
B	Food Grade Grease
C	Nuclear Grade Oil
D	Nuclear Grade Grease
E	Biodegradable Oil
F	Biodegradable Grease

30-Paint	
0	Standard Paint (Red)
1	Standard Primer (Grey) Only
2	Standard Epoxy Paint (Red)
3	Subsea Paint (Yellow)
4	No Paint

**Notes:**

- #1 Internal design revision number leave as XX and Power Jacks will update at time of order.
- #2 Not applicable to hollow shaft gearboxes.
- #3 Select if hollow shaft gearboxes with standard shaft designs on hollow shaft.
- #4 Keyless shaft design, typically for servo couplings.
- #5 Suitable for horizontal gearbox mounting, running within allowable speed limits for lubrication.
- #6 Common side for breather on horizontally mounted gearbox (on side 5) with oil lubrication
- #7 Common side for 90deg breather on 2-way or 3-way horizontally mounted gearbox (on side 5) with oil lubrication
- #8 The environment and temperature range specified here dictates the seal type and temperature rating of the gearbox, hence temperature rating / type of lubricant as well.
- #9 Type / Grade of lubricant defined by character 29 and 18
- #10 The gearboxes "Through Shaft" is reinforced to transmit higher torque. It does not increase the torque transmitted through the gear set.

When selecting a gearbox, there are a number of factors which can influence the final size of unit selected. The information contained in the selections gearbox characteristics and Technical data provide details of these factors for use in the selection process.

The following Selection Procedure provides a step-by-step guide to gearbox selection for those not fully familiar with the procedures. An example has been used in the selection procedure to assist in following through the procedure.

Specified information	Example Information
1. Gearbox Input Speed (rpm)	1000
2. Gearbox Output Speed (rpm)	500
3. Gearbox Configuration (page 213)	2 Way
4. Required Output Torque (Nm)	150
5. Operating Hours per Day (HRS)	10
6. Input Power Source (page 210)	Electric Motor
7. Gearbox Application (page 210)	Stacking Machine
8. Number of Starts per Hour (page 210)	8
9. Transmission Methods (page 210)	Clutch
10. Duty Cycle per Hour (% Running time)	45/60 = 75%
11. Operating Ambient Temperature °C (page 211)	20

Selection of Design Factors	Example Design Factors
<b>Step 1 - Shock Load Factor (<math>f_1</math>)</b> Using the Specified Information in Points 5, 6 and 7 above, select the Shock Load Factor from the Page 210.	1.25
<b>Step 2 - Starting Frequency Factor (<math>f_2</math>)</b> Using the Specified Information in Point 8 above, select the Starting Frequency Factor from the page 210.	1.00
<b>Step 3 - Transmission Load Factor (<math>f_3</math>)</b> Using the Specified Information in Point 9 above, select the Transmission Load Factor from the Page 210.	1.00
<b>Step 4 - Thermal Limit - Duty Cycle - Factor (<math>f_4</math>)</b> Using the Specified Information in Point 10 above, select the Thermal Limit - Duty Cycle - Factor from the Page 210.	1.25
<b>Step 5 - Thermal Limit- Ambient Temperature - Factor (<math>f_5</math>)</b> Using the Specified Information in Point 11 above, select the Thermal Limit - Ambient Temperature -Factor from the Page 211.	1.00



A gearbox is required for an Input Speed of 1000 rpm, an Output Speed of 500 rpm, an Output Torque of 150Nm and one Output Shaft. The Drive is by electric motor through a clutch mechanism and the gearbox is on the main drive of a heavy duty stacking machine. The machine operates for 10 hours per day, starts 8 times per hour and operates for 45 minutes in every hour, the other 15 minutes being taken up in loading the machine. The ambient temperature of the premises is 20°C.

Calculated data

Example Data

<p><b>Step 6</b> - Calculate the Gear Ratio                  Input Speed ÷ Output Speed                  Note: If the gear ratio does not correspond to one of the STANDARD ratios contained in this technical manual, one of the speeds, normally the output speed, must be changed to bring the ratio to standard. Non-standard ratios can be supplied, if required, but such special selections must be referred to Power Jacks.</p>	<p>1000/500 = 2                  Therefore 2:1 Reduction</p>
<p><b>Step 7</b> - Calculate the Corrected Output Torque                  Required Output Torque x <math>f_1</math> x <math>f_2</math> x <math>f_3</math>                  Note: Where there is more than one output shaft, the Required Output Torque for the gearbox is the summation of the individual Output Torques from the output shafts.</p>	<p>150 x 1.25 x 1.00 x 1.00 x = 187.5 Nm</p>
<p><b>Step 8</b> - Calculate the Corrected Output Power                  Required Output Torque x Output Speed / 9550</p>	<p>(187.5 x 500) / 9550 = 9.82 kW</p>
<p><b>Step 9</b> - Calculate the Required Input Power = Output Power / Efficiency (Gearbox efficiency is between 95% and 98% after initial running in).</p>	<p>9.82 / 0.98 = 10.02 kW</p>

Gearbox Selection

Example Gearbox Selection

<p><b>Step 10</b> - From the GEARBOX TORQUE x POWER RATING TABLE (page 209), select the gearbox with the closest adequate rated power.</p>	<p>From the Selection Table on page 209, for Input Power 10.02 kW, gear ratio 2:1 and Input Speed 1000 rpm, select Series 39.</p>
<p><b>Step 11</b> - When selecting a gearbox, the Thermal Capacity of the gearbox chosen must be considered. For the Limiting Thermal Capacity (page 211), expressed as a Power Rating. For the selected gearbox, calculate the Thermal Capacity = Limiting Thermal Capacity x <math>f_4</math> x <math>f_5</math>.                  The Calculated Input Power must not exceed this Calculated Thermal Capacity. A larger gearbox must be selected if the Calculated Input Power is higher and a check run on the other parameters.</p>	<p>From the table in page 211, Limiting Thermal Capacity for Series 39 is 49kW.                   Calculate the gearbox,                  Thermal Capacity = 49 x 1.25 x 1.00 = 61.25 kW                   The Input Power is within this limit. Selected gearbox is OK.</p>
<p><b>Step 12</b> - As a final check on the capacity of the chosen gearbox, the effect of the connected drive systems must be considered. The section headed Permissible Shaft Loading (page 212) describes the calculation to be undertaken where the transmission mechanism can give rise to radial and/or axial forces on the gear shafts. This occurs, particularly, where chain and belt drives are employed.</p>	<p>Power transmission is by clutch. From the Transmission Load Factor table (page 210 (<math>f_3</math>)), there are no additional loads to be considered and the selection of gearbox is acceptable.</p>

Series		35	37	38	39	40	42 <sup>#3</sup>
Torque (Nm)	Nominal <sup>#1</sup>	46	115	328	481	1353	6195
	Max Running <sup>#2</sup>	93	187	505	935	3088	7000
	Max Start-Up	140	281	758	1403	4632	10500
Input Speed	Max (rpm)	3000	3000	3000	3000	3000	3000
Thermal Limit	Power (kW)	3.3	9	20.5	49	90	190
Backlash	arcmin	9 to 16	9 to 16	9 to 16	7 to 10	7 to 10	7 to 10
Efficiency (%)		95% - 98%					
Service Life	(hours)	>10000	>10000	>10000	>10000	>10000	>10000
Housing Material		SG Iron	SG Iron	SG Iron	SG Iron	SG Iron	SG Iron
Oil Quantity	Litres	0.14	0.29	0.75	1.71	3.27	7
	Pints	0.24	0.5	1.32	3	5.75	12.3
Weight (kg)	2 Way - 1:1 & 1.5:1	5.25	11	21.75	53.25	125	190
	2 Way - 2:1 +	5.5	11	22	54.5	125	215
	3 Way - 1:1 & 1.5:1	5.5	11.5	22	54.5	128	197
	3 Way - 2:1 +	6	11.5	22.5	55.75	128	223
	4 Way - 1:1 & 1.5:1	6	13	25	64	150	204
	4 Way - 2:1 +	7	14	27	69.5	153	231

The above tables and other torque & power tables are on the basis of the following nominal values:

- 1 Shock-free operation
- 2 Operating time per day = 8 hours
- 3 Maximum 20 starts per hour (torque x 1.5 permissible)
- 4 Duty cycle 100%
- 5 When selecting gearboxes take the thermal capacity into consideration
- 6 Ambient temperature for operation -10° to +50°C permissible

Notes:

- #1 Nominal torque values at running speeds of 1500 rpm  
 #2 Maximum running torque value at speed of 10 rpm  
 #3 42-Series is Range-N design.

## Lubrication

The oil levels stated in the table above assumes that the gearbox is positioned with all shafts in a horizontal plane. To get the correct lubrication recommendation please supply shaft orientation and operating speeds required as part of the application details provided to Power Jacks with an enquiry.

! All Range-C gearboxes are shipped without lubrication, except for grease filled units.

### Input Speeds: 250 rpm < n < 1500 rpm

For input speeds up to 1500 rpm the oil level in the gearbox should be maintained just below the centre line of the shafts.

### Input Speeds: n > 1500 rpm

For input speeds above 1500 rpm a change in oil level may be required in combination with a breather (vent). Consult Power Jacks for specific application advice.

### Input Speeds: 250 rpm < n

For input speeds below 250 rpm then a grease filled gearbox is recommended.

### Oil Specification

Ambient Temperature	Gear Oil
Below +5C	ISO 150
+5C to +40C	ISO 220
Above +40C	ISO 320

### Grease Specification

Use an EP1 rated grease.



Gear Unit Size		Gear	Input Speeds										
		Ratio	10	50	100	250	500	750	1000	1500	2000	2500	3000
Series 35	Power (kW)	1:1	0.1	0.4	0.8	1.7	3.1	4.3	5.4	7.4	8.9	10.3	11.6
		1.5:1	0.04	0.2	0.4	0.7	1.4	2.1	2.6	3.7	4.7	5.8	6.8
		2:1	0.03	0.12	0.2	0.5	0.9	1.2	1.6	2.2	2.9	3.6	4.3
		3:1	0.01	0.03	0.06	0.15	0.31	0.5	0.6	0.9	1.2	1.4	1.7
	Output Torque M2 (Nm)	1:1	93	74	74	63	58	53	50	46	41	38	36
		1.5:1	56	56	56	39	39	39	36	34	32	32	31
		2:1	56	44	37	37	33	29	29	27	27	26	26
Series 37	Power (kW)	1:1	0.2	1	2	4.3	7.7	10.8	13.6	18.5	22.6	26.3	30.6
		1.5:1	0.1	0.5	0.8	1.9	3.5	5	6.4	9	11.5	14.3	17
		2:1	0.1	0.3	0.6	1.3	2.5	3.5	4.5	6.4	8.1	10.1	12
		3:1	0.03	0.11	0.2	0.5	0.8	1.2	1.5	2.1	2.8	3.5	4.2
		4:1	0.01	0.06	0.1	0.2	0.4	0.6	0.8	1.2	1.5	1.9	2.3
	Output Torque M2 (Nm)	1:1	187	187	187	160	144	134	127	115	105	98	95
		1.5:1	140	140	112	106	98	93	89	84	80	80	79
Series 38	Power (kW)	1:1	0.54	2.7	5.3	11.7	21.2	29.9	38	52.6	65.1	76.6	-
		1.5:1	0.2	0.9	1.6	3.4	6.1	8.7	11.1	15.5	19.4	23.6	27.6
		2:1	0.27	0.6	1.2	2.6	4.8	6.9	9	12.8	16.6	20.8	25
		3:1	0.1	0.3	0.5	1.2	2.2	3.1	4	5.7	7.5	9.4	11.1
		4:1	0.03	0.13	0.23	0.7	0.9	1.3	1.7	2.4	3.2	4	4.8
	Output Torque M2 (Nm)	1:1	505	505	495	437	396	373	355	328	304	286	-
		1.5:1	280	252	224	190	171	162	155	145	136	132	129
Series 39	Power (kW)	1:1	1	5	9.8	22.2	38.6	52	62.9	77.2	-	-	-
		1.5:1	0.4	1.8	3.6	9	16.3	23.2	29.7	41.8	52.5	63.6	-
		2:1	0.5	2	3.6	7.9	14.5	20.7	26.6	38	49.5	60.7	71.4
		3:1	0.2	0.8	1.4	3.2	5.9	8.4	10.9	15.6	20.5	25.1	29.4
		4:1	0.1	0.4	0.7	1.6	2.9	4.2	5.4	7.7	10.2	12.5	14.7
	Output Torque M2 (Nm)	1:1	935	935	917	831	722	648	588	481	-	-	-
		1.5:1	505	505	505	505	457	434	416	391	368	357	-
Series 40	Power (kW)	1:1	3.3	16.2	31.8	74.3	126	166	194	-	-	-	-
		1.5:1	1.9	8.9	16.3	36.4	65.6	90.8	112	145	-	-	-
		2:1	1.5	6.8	12.5	28	52	74.8	96.7	139	181	221.5	-
		3:1	0.7	2.6	4.5	10.3	19.2	27.8	36.1	52	68.3	83.6	98.3
		4:1	0.4	1.5	2.8	7	11.7	16.9	21.9	31.6	42.1	51.5	60.5
	Output Torque M2 (Nm)	1:1	3088	3032	2975	2781	2358	2071	1815	-	-	-	-
		1.5:1	2667	2498	2288	2043	1841	1699	1572	1356	-	-	-
2:1		2807	2545	2339	2096	1946	1866	1809	1734	1693	1658	-	
3:1		1965	1459	1263	1156	1078	1040	1013	973	958	938	919	
Series 42	Power (kW)	1:1	7.5	37.4	74.8	187	374	558	-	-	-	-	-
		1.5:1	3.5	17.3	34.5	86.1	172	245	310	-	-	-	-
		2:1	3.7	17.6	32.6	73.8	138	198	255	361	-	-	-
		3:1	0.72	3.6	7.2	18	37.1	53.4	68.3	98.4	128.5	157.3	-
		4:1	1	3.7	6.7	14.9	28	40.6	52.8	76.3	97.7	119.7	140.8
	Output Torque M2 (Nm)	1:1	7000	7000	7000	7000	7000	6962	-	-	-	-	-
		1.5:1	4913	4856	4842	4834	4828	4585	4351	-	-	-	-
2:1		6925	6588	6101	5525	5165	4941	4772	4504	-	-	-	
Series 42	Output Torque M2 (Nm)	3:1	2021	2021	2021	2021	2083	1998	1917	1841	1803	1766	-
		4:1	3743	2770	2508	2231	2096	2026	1976	1904	1828	1972	1756

■ Check Thermal Limit - Power

■ Check Thermal Limit - Torque

Power Ratings (kW) @ given INPUT speeds (rpm)  
Output Torque M2 (Nm) @ given INPUT speeds (rpm)

Shock Load Factor ( $f_1$ )

Shock Load Category		
I	II	III
Conveyor Belts	Heavy Duty Lifts	Punching Machine
Generators	Hoists	Shears
Ventilators	Mixers	Forging Presses
Light Textile Machinery	Cranes	Vibrators
Rotating Machine Tools	Heavy Duty Textile Machinery	Rolling Mills
	Woodworking Machinery	Extremely Heavy Lifts
	Paper Machinery	Heavy Duty Roller Conveyors

Shock Load Category	Input Power Source								
	Electric Motor			Piston Machine Hydro Motor			Single Cylinder Piston Machine		
	Operating Time per Day (hrs)			Operating Time per Day (hrs)			Operating Time per Day (hrs)		
	≤2	10	>10	≤2	10	>10	≤2	10	>10
I	0.9	1	1.25	1	1.25	1.5	1.25	1.5	1.75
II	1	1.25	1.5	1.25	1.5	1.75	1.5	1.75	2
III	1.5	1.5	1.75	1.75	2	2.25	2	2.25	2.5

Starting Frequency Factor ( $f_2$ )

up to 20 starts per hour  $f_2 = 1.0$

up to 60 starts per hour  $f_2 = 1.1$

up to 200 starts per hour  $f_2 = 1.3$

up to 600 starts per hour  $f_2 = 1.5$

more than 600 starts per hour (on request)

Transmission Load Factor ( $f_3$ )

The total load on the drive shafts and their bearing is the result of:

- The loads arising from the gear teeth
- The axial and radial loads arising from the transmission mechanisms attached to the drive shafts. It is this load which must be considered when selecting the gearbox and shaft sizes.

Depending upon the type of transmission mechanism used in connecting the gear shafts to the driving and driven loads, axial and / or radial loads can be applied to the gearbox shafts and their bearings.

These loads can arise from:

- either preload, due for example, to tension loading in belts
- or dynamic forces, due for example, to out-of-balance in the transmission element
- or shock load, due for example, to snatching in a chain drive.

The following table gives the factors which should be used to correct the Output Torque when sizing the gearbox.

Transmission Mechanism	Transmission Load Factor ( $f_3$ )	
	Preload	Dynamic
Clutches	-	1
Gears of all Types	-	1.00 to 1.25
Chains	1.00 to 1.25	1.25 to 1.50
Flat Belts	2.00 to 2.50	1.00 to 1.25
V-Belts, Toothed Belts	1.50 to 2.00	1.00 to 1.25

Due to the compact design of this range of spiral bevel gear units the ratings are controlled by the thermal capacity at some speeds. A maximum case temperature of 80°C is specified and temperatures in excess of this figure normally indicate either incorrect oil levels or too much power being handled by the unit. If this temperature is exceeded Power Jacks should be consulted.

### Thermal Limit - Duty Cycle - Factor ( $f_4$ )

Duty cycle per hour is the percentage of the time per hour during which the gearbox will be on-load.

Duty Cycle per Hour (%)	100	80	60	40	20
Thermal Limit Factor, $f_4$	1	1.25	1.5	1.75	2

### Thermal Limit - Ambient Temperature - Factor ( $f_5$ )

Ambient Temperature °C	10	20	30	40	50
Thermal Limit Factor, $f_5$	1.2	1	0.87	0.75	0.62

### Limiting Thermal Capacity

The capacity of some gears is limited by the maximum permissible temperature of the oil bath. The charts below show the limiting thermal capacities, which can be transferred without cooling at an ambient temperature of 20°C and duty cycle of 100% per hour.

Series	35	37	38	39	40	42
Power (kW)	3.3	9	20.5	49	90	190

WARNING: The case temperature must not exceed 80°C, (see thermal limits).

Power Jacks should be consulted if a gear unit is to be installed with a shaft positioned vertically.

After selecting the gearbox for the required duty it is necessary to check that the axial and radial loading arising from the transmission mechanism is acceptable for the gear shaft diameters on the selected gearbox (gear shaft diameters are given on the Dimensions page for the chosen design).

The bearing configuration on the shafting, the shaft diameter and the shaft speed determine the permissible external loading which can be carried by the shaft without bearing or shaft failure. The graph showing permissible radial forces on shafts has been drawn for a typical Output Shaft. In this arrangement the bearing centres are mounted at either end of the through shaft and there is a significant span which allows higher radial loads to be accepted, see sketch below. For typical Input Shafts and Output Shafts, which are overhung from the gearbox face, the bearing centres are closer together and the radial load carrying capacity is reduced, see sketch below.

To calculate the Permissible Loading on the gearbox shafts, use the gearbox output and input speeds and diameters respectively.

1. Read off the Permissible radial Force for the nearest diameter shafts from the graph below.
2. Use the Correction Factors, below, to calculate the Permissible Radial and Axial Loads for each of the gearbox shafts.

### Correction Factors

	Output Shaft (Bearings on through shaft)	Input Shaft (Bearings on overhung shaft)	Output Shaft (Bearings on overhung shaft)	Gearboxes with Centre bearing
Permissible Radial Forces	1.00	0.66	0.66	0.40
Permissible Axial Forces	0.50	0.50	0.50	0.50

The calculated loads should be checked against the radial and axial loads provided by the manufacturer of the transmission mechanism. If the loading created by the transmission mechanism exceeds the permissible level, a gearbox with a larger diameter shaft is required. At this point Power Jacks should be consulted as it is often possible to fit a special shaft arrangement into a standard gearbox.

### Permissible Shaft Loading Curves

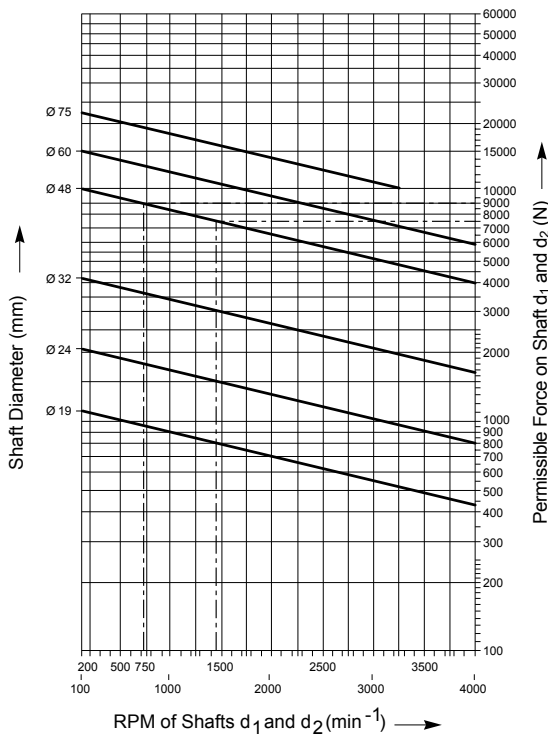

Permissible Shaft Loading Curves

### Example: Series 39, Ratio 2:1, 1440 rpm Input

$\varnothing d_1$	=	48	permissible radial force 7500 N x 0.66 = 4950 N permissible axial force 4950 N x 0.50 = 2475 N
$\varnothing d_2$	=	48	permissible radial force 9000 N x 1.00 = 9000 N permissible axial force 9000 N x 0.50 = 4500 N

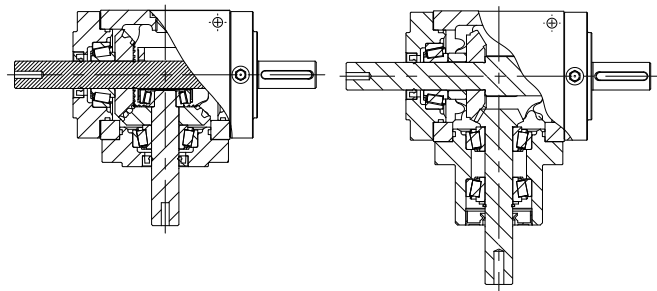

Ratios 1:1 & 1.5:1

Ratios 2:1 & above

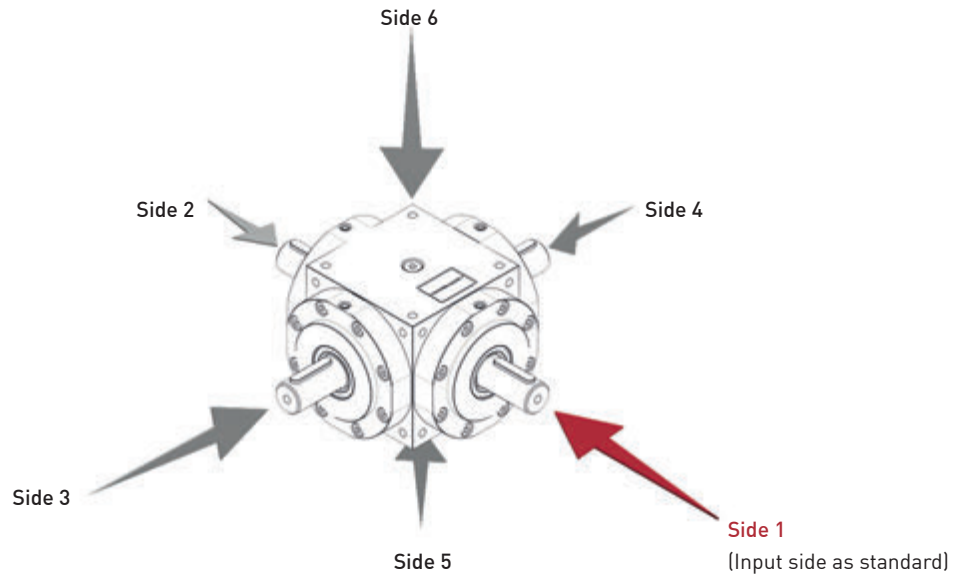

Ratio 1:1 & 1.5:1



Ratio 2:1 & Above

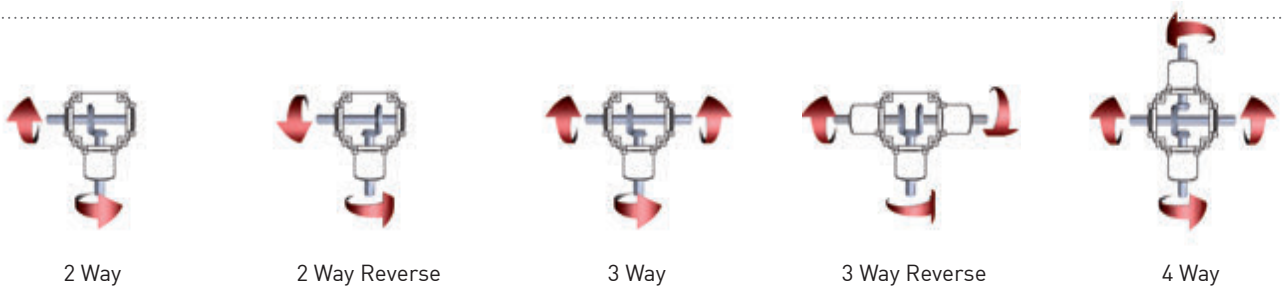

Hollow Shaft - All Ratios

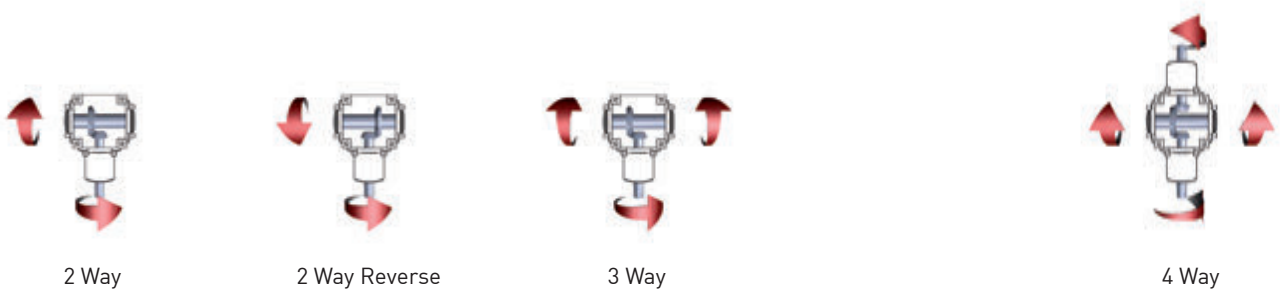

### Performance

Series 35		
Torque (Nm)	Nominal#1	46
	Max Running#2	93
	Max Start-Up	140
Input Speed	Max (rpm)	3000
Thermal Limit	Power (kW)	3.3
Backlash	arcmin	9 to 16
Efficiency	(%)	95% - 98%
Service Life	(hours)	>10000
Housing Material		SG Iron
Oil Quantity	Litres	0.14
	Pints	0.24
Weight (kg)	2 Way - 1:1 & 1.5:1	5.25
	3 Way - 1:1 & 1.5:1	5.5
	4 Way - 1:1 & 1.5:1	6



















**Notes:**

#1 Nominal torque values at running speeds of 1500 rpm

#2 Maximum running torque value at speed of 10 rpm

Full detailed performance for each unit refer to page 16 & 17

### Accessories & Options

	Special Gear Ratio		Motor Flange
	Extended Drive Shaft		Limit Switches
	Drives		Light Weight Design
	Reinforced Shaft OR High Torque		Breather
	90° Breather		Mounting Feet
	Shaft Cover		Stainless Steel
	Submersible		Corrosion Protection
	Nuclear Rated		Food Grade
	Low Temperature		High Temperature

### 2 Way Solid Shaft

C350S20-10

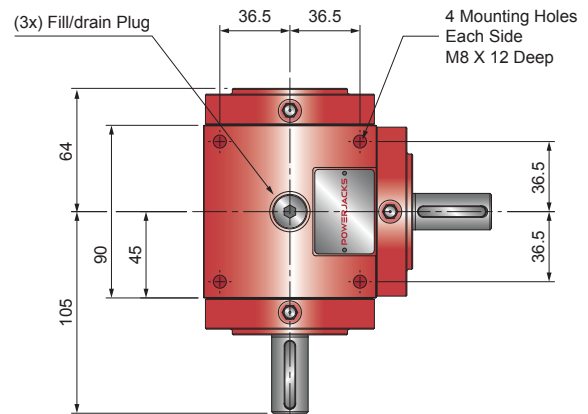

Tapped hole in end of each solid drive shaft - M6 x 16mm Deep

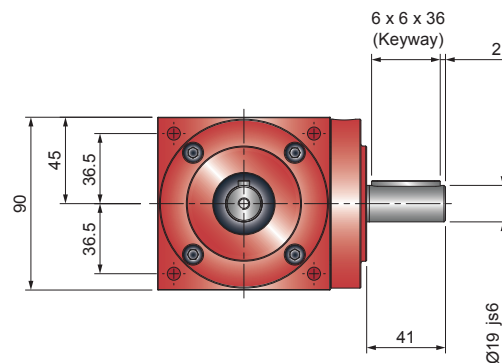

**Notes:**

1. All dimensions in mm unless otherwise stated
2. Dimensions subject to change without notice

### 3 Way Solid Shaft

C350S30-10

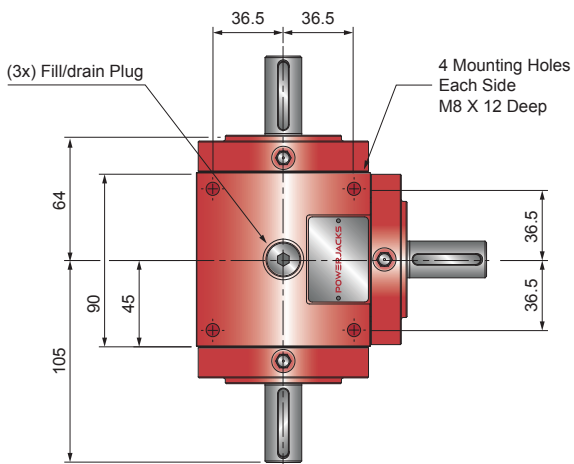

Tapped hole in end of each solid drive shaft - M6 x 16mm Deep

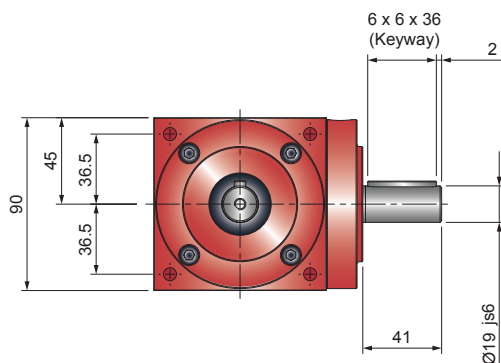

Notes:

1. All dimensions in mm unless otherwise stated
2. Dimensions subject to change without notice

### 4 Way Solid Shaft

C350S40-10

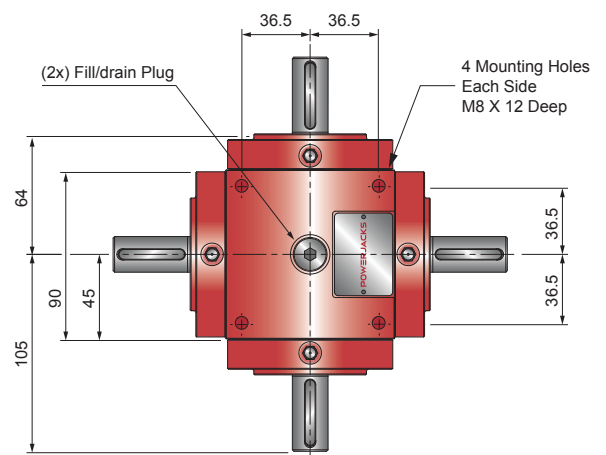

Tapped hole in end of each solid drive shaft - M6 x 16mm Deep

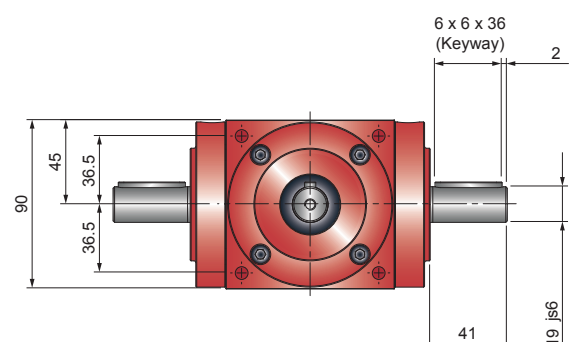

Notes:

1. All dimensions in mm unless otherwise stated
2. Dimensions subject to change without notice



















### Performance

Series 35		
Torque (Nm)	Nominal#1	46
	Max Running#2	93
	Max Start-Up	140
Input Speed	Max (rpm)	3000
Thermal Limit	Power (kW)	3.3
Backlash	arcmin	9 to 16
Efficiency	(%)	95% - 98%
Service Life	(hours)	>10000
Housing Material		SG Iron
Oil Quantity	Litres	0.14
	Pints	0.24
Weight (kg)	2 Way - 2:1 +	5.5
	3 Way - 2:1 +	6
	4 Way - 2:1 +	7

**Notes:**

#1 Nominal torque values at running speeds of 1500 rpm  
 #2 Maximum running torque value at speed of 10 rpm  
 Full detailed performance for each unit refer to page 16 & 17

### Accessories & Options

	Special Gear Ratio		Motor Flange
	Extended Drive Shaft		Limit Switches
	Drives		Light Weight Design
	Reinforced Shaft OR High Torque		Breather
	90° Breather		Mounting Feet
	Shaft Cover		Stainless Steel
	Submersible		Corrosion Protection
	Nuclear Rated		Food Grade
	Low Temperature		High Temperature

### 2 Way Solid Shaft

C350S20-20

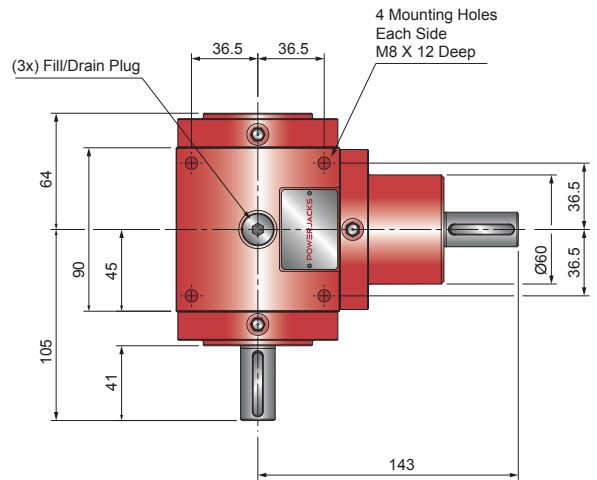

Tapped hole in end of each solid drive shaft - M6 x 16mm Deep

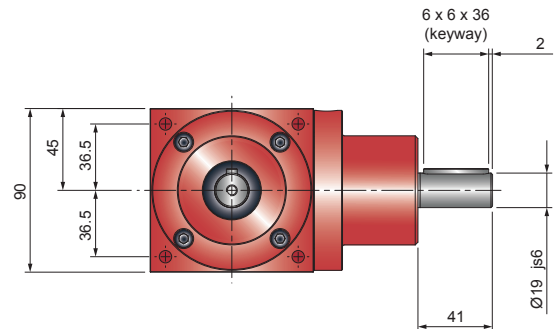

**Notes:**

1. All dimensions in mm unless otherwise stated
2. Dimensions subject to change without notice



### 3 Way Solid Shaft

C350S30-20

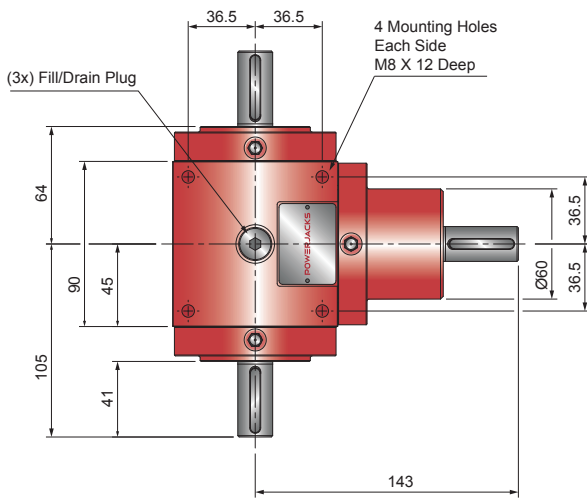

Tapped hole in end of each solid drive shaft - M6 x 16mm Deep

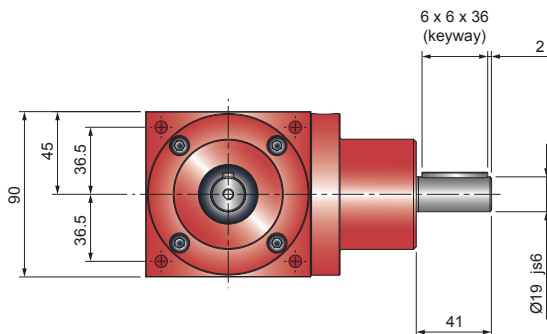

Notes:

1. All dimensions in mm unless otherwise stated
2. Dimensions subject to change without notice

### 4 Way Solid Shaft

C350S40-20

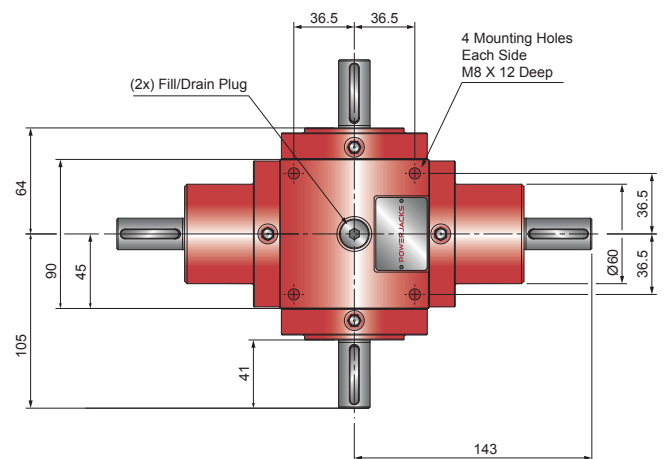

Tapped hole in end of each solid drive shaft - M6 x 16mm Deep

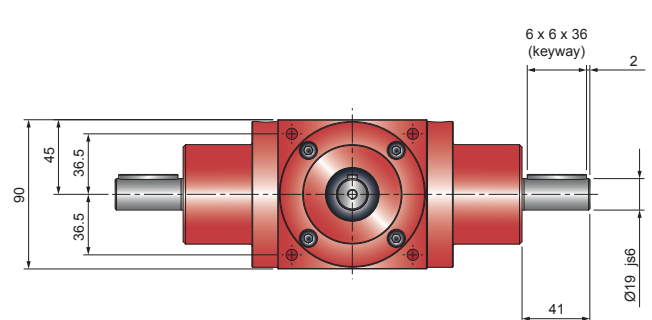

Notes:

1. All dimensions in mm unless otherwise stated
2. Dimensions subject to change without notice

### Performance

Series 35		
Torque (Nm)	Nominal#1	46
	Max Running#2	93
	Max Start-Up	140
Input Speed	Max (rpm)	3000
Thermal Limit	Power (kW)	3.3
Backlash	arcmin	9 to 16
Efficiency	(%)	95% - 98%
Service Life	(hours)	>10000
Housing Material		SG Iron
Oil Quantity	Litres	0.14
	Pints	0.24
Weight (kg)	2 Way - 1:1 & 1.5:1	5.25
	2 Way - 2:1 +	5.5
	3 Way - 1:1 & 1.5:1	5.5
	3 Way - 2:1 +	6
	4 Way - 1:1 & 1.5:1	6
	4 Way - 2:1 +	7



















**Notes:**

#1 Nominal torque values at running speeds of 1500 rpm

#2 Maximum running torque value at speed of 10 rpm

Full detailed performance for each unit refer to page 16 & 17

### Accessories & Options

	Special Gear Ratio		Motor Flange
	Extended Drive Shaft		Limit Switches
	Drives		Light Weight Design
	Reinforced Shaft OR High Torque		Breather
	90° Breather		Mounting Feet
	Shaft Cover		Stainless Steel
	Submersible		Corrosion Protection
	Nuclear Rated		Food Grade
	Low Temperature		High Temperature

### 2 Way Hollow Shaft

C350H20-10

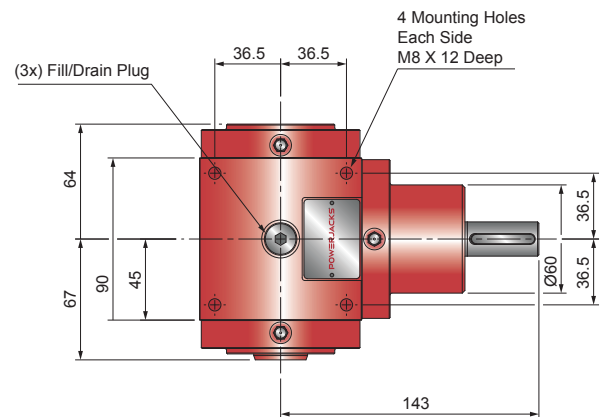

Tapped hole in end of each solid drive shaft - M6 x 16mm Deep

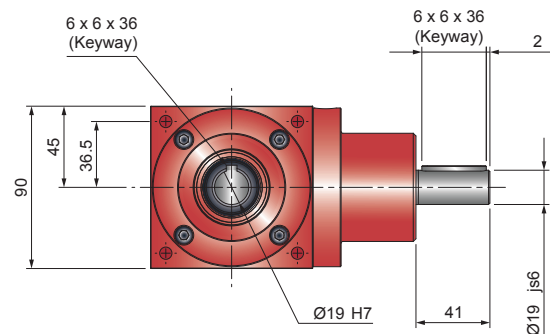

**Notes:**

1. All dimensions in mm unless otherwise stated
2. Dimensions subject to change without notice

## 3 Way Hollow Shaft

C350H30-10

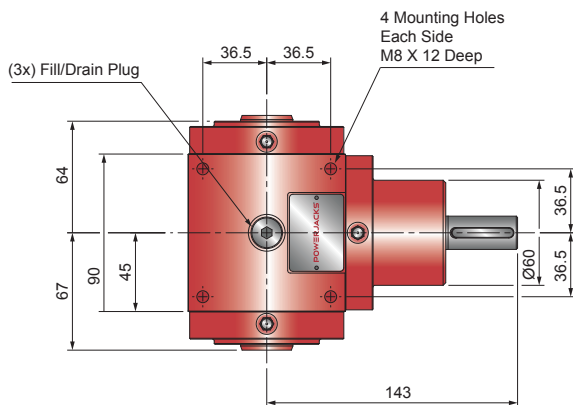

Tapped hole in end of each solid drive shaft - M6 x 16mm Deep

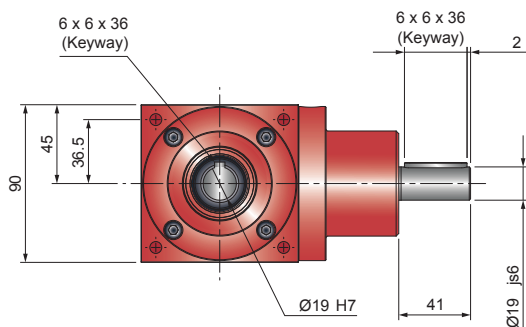

Notes:

1. All dimensions in mm unless otherwise stated
2. Dimensions subject to change without notice

## 4 Way Hollow Shaft

C350H40-10

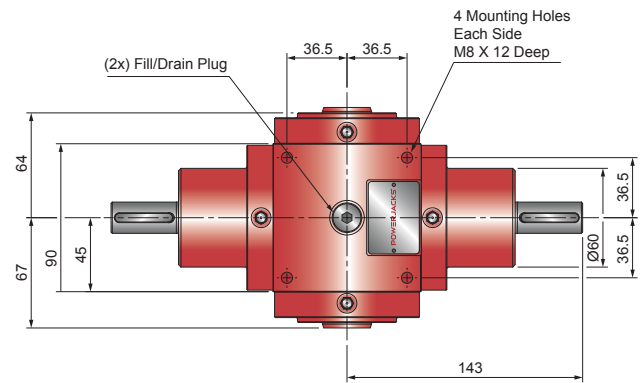

Tapped hole in end of each solid drive shaft - M6 x 16mm Deep

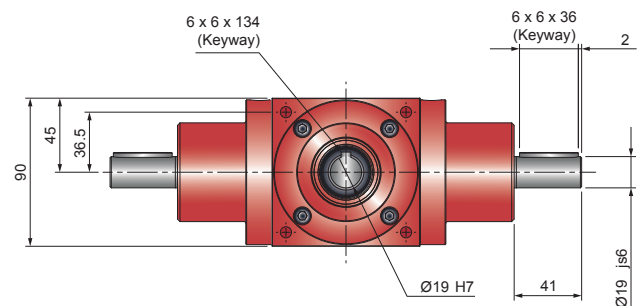

Notes:

1. All dimensions in mm unless otherwise stated
2. Dimensions subject to change without notice

### Performance

Series 37		
Torque (Nm)	Nominal#1	115
	Max Running#2	187
	Max Start-Up	281
Input Speed	Max (rpm)	3000
Thermal Limit	Power (kW)	9
Backlash	arcmin	9 to 16
Efficiency	(%)	95% - 98%
Service Life	(hours)	>10000
Housing Material		SG Iron
Oil Quantity	Litres	0.29
	Pints	0.5
Weight (kg)	2 Way - 1:1 & 1.5:1	11
	3 Way - 1:1 & 1.5:1	11.5
	4 Way - 1:1 & 1.5:1	13



















**Notes:**

#1 Nominal torque values at running speeds of 1500 rpm

#2 Maximum running torque value at speed of 10 rpm

Full detailed performance for each unit refer to page 16 & 17

### Accessories & Options

	Special Gear Ratio		Motor Flange
	Extended Drive Shaft		Limit Switches
	Drives		Light Weight Design
	Reinforced Shaft OR High Torque		Breather
	90° Breather		Mounting Feet
	Shaft Cover		Stainless Steel
	Submersible		Corrosion Protection
	Nuclear Rated		Food Grade
	Low Temperature		High Temperature

### 2 Way Solid Shaft

C370S20-10

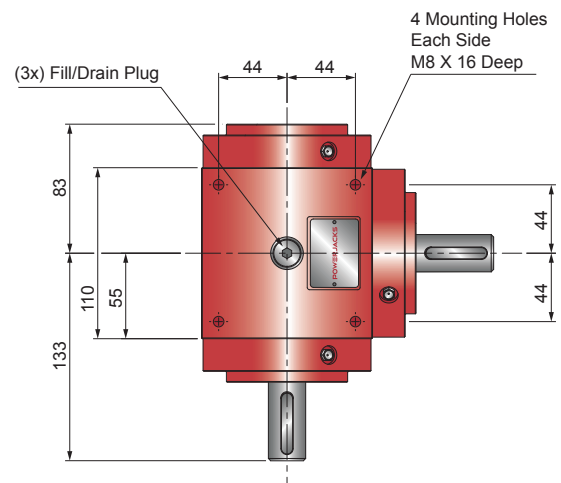

Tapped hole in end of each solid drive shaft - M8 x 25mm Deep

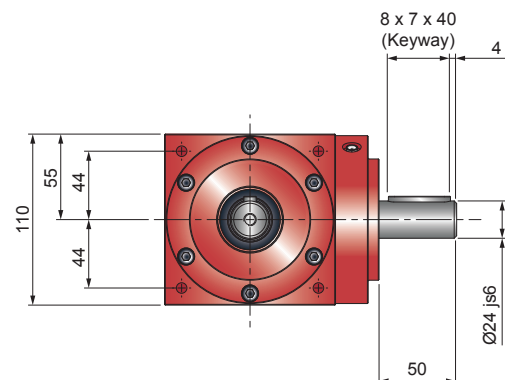

**Notes:**

1. All dimensions in mm unless otherwise stated
2. Dimensions subject to change without notice

### 3 Way Solid Shaft

C370S30-10

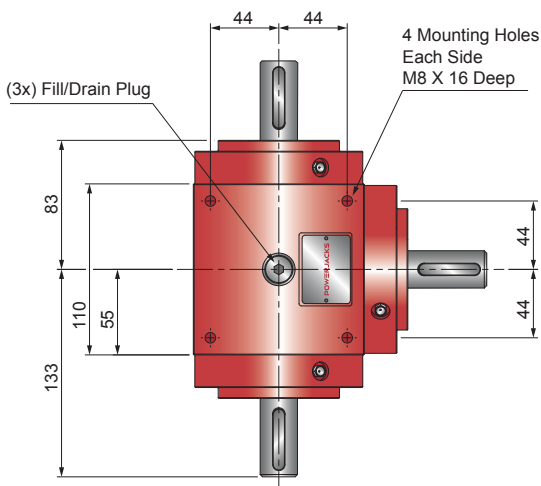

Tapped hole in end of each solid drive shaft - M8 x 25mm Deep

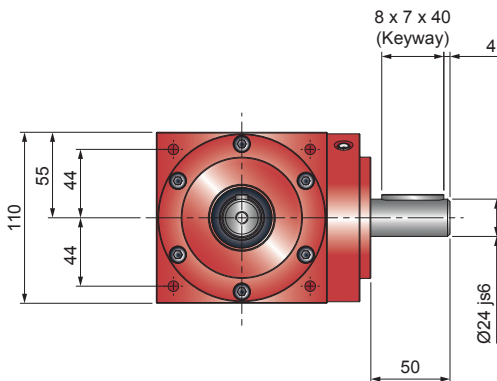

Notes:

1. All dimensions in mm unless otherwise stated
2. Dimensions subject to change without notice

### 4 Way Solid Shaft

C370S40-10

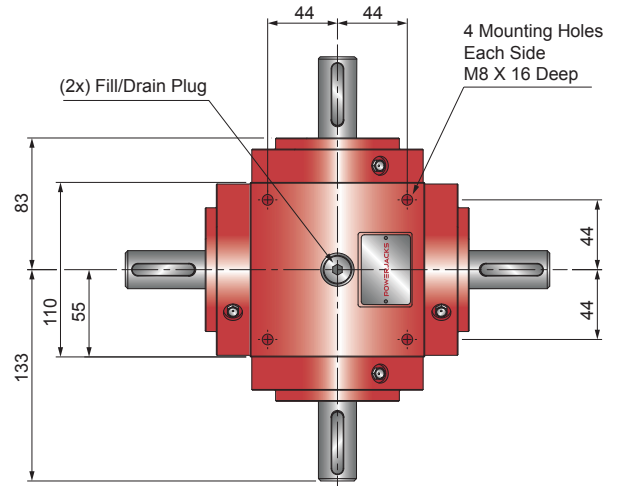

Tapped hole in end of each solid drive shaft - M8 x 25mm Deep

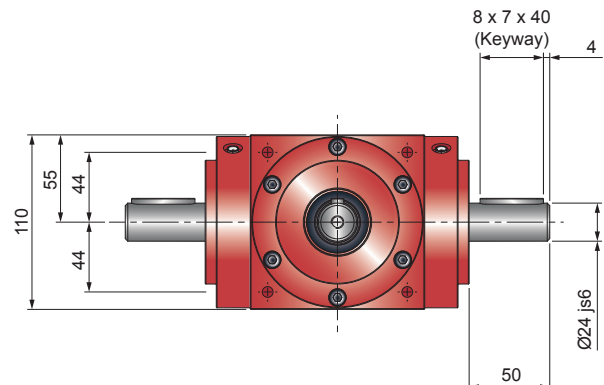

Notes:

1. All dimensions in mm unless otherwise stated
2. Dimensions subject to change without notice



















### Performance

Series 37		
Torque (Nm)	Nominal#1	115
	Max Running#2	187
	Max Start-Up	281
Input Speed	Max (rpm)	3000
Thermal Limit	Power (kW)	9
Backlash	arcmin	9 to 16
Efficiency	(%)	95% - 98%
Service Life	(hours)	>10000
Housing Material		SG Iron
Oil Quantity	Litres	0.29
	Pints	0.5
Weight (kg)	2 Way - 2:1 +	11
	3 Way - 2:1 +	11.5
	4 Way - 2:1 +	14

Notes:

#1 Nominal torque values at running speeds of 1500 rpm  
 #2 Maximum running torque value at speed of 10 rpm  
 Full detailed performance for each unit refer to page 16 & 17

### Accessories & Options

	Special Gear Ratio		Motor Flange
	Extended Drive Shaft		Limit Switches
	Drives		Light Weight Design
	Reinforced Shaft OR High Torque		Breather
	90° Breather		Mounting Feet
	Shaft Cover		Stainless Steel
	Submersible		Corrosion Protection
	Nuclear Rated		Food Grade
	Low Temperature		High Temperature

### 2 Way Solid Shaft

C370S20-20

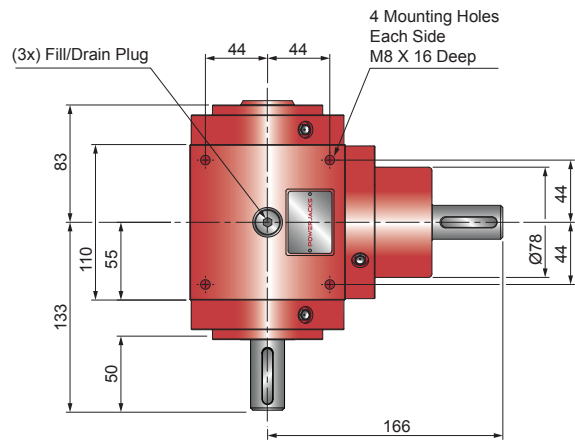

Tapped hole in end of each solid drive shaft - M8 x 25mm Deep

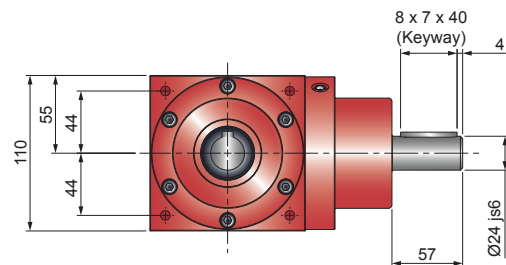

Notes:

1. All dimensions in mm unless otherwise stated
2. Dimensions subject to change without notice

### 3 Way Solid Shaft

C370S30-20

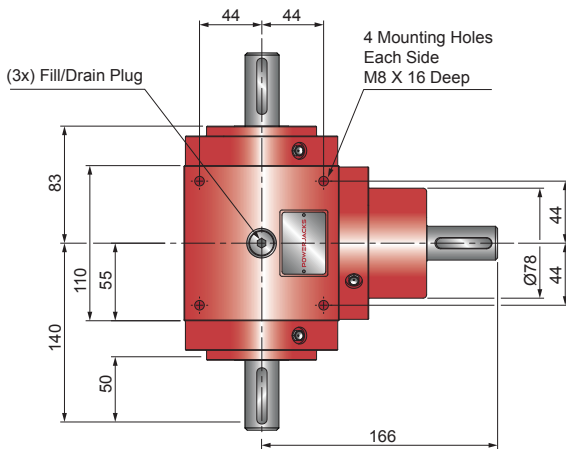

Tapped hole in end of each solid drive shaft - M8 x 25mm Deep

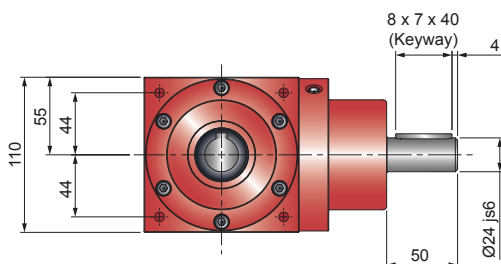

Notes:

1. All dimensions in mm unless otherwise stated
2. Dimensions subject to change without notice

### 4 Way Solid Shaft

C370S40-20

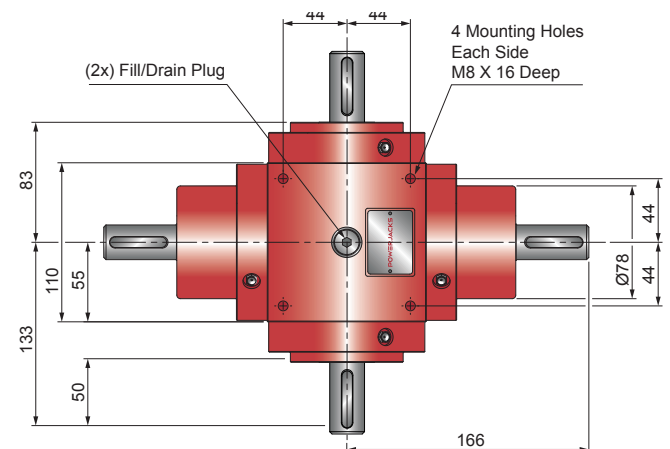

Tapped hole in end of each solid drive shaft - M8 x 25mm Deep

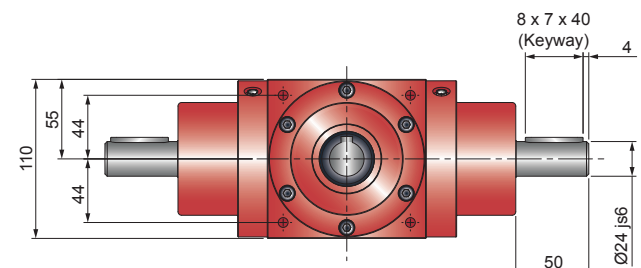

Notes:

1. All dimensions in mm unless otherwise stated
2. Dimensions subject to change without notice

### Performance

Series 37		
Torque (Nm)	Nominal#1	115
	Max Running#2	187
	Max Start-Up	281
Input Speed	Max (rpm)	3000
Thermal Limit	Power (kW)	9
Backlash	arcmin	9 to 16
Efficiency	(%)	95% - 98%
Service Life	(hours)	>10000
Housing Material		SG Iron
Oil Quantity	Litres	0.29
	Pints	0.5
Weight (kg)	2 Way - 1:1 & 1.5:1	11
	2 Way - 2:1 +	11
	3 Way - 1:1 & 1.5:1	11.5
	3 Way - 2:1 +	11.5
	4 Way - 1:1 & 1.5:1	13
	4 Way - 2:1 +	14



















**Notes:**

#1 Nominal torque values at running speeds of 1500 rpm

#2 Maximum running torque value at speed of 10 rpm

Full detailed performance for each unit refer to page 16 & 17

### Accessories & Options

	Special Gear Ratio		Motor Flange
	Extended Drive Shaft		Limit Switches
	Drives		Light Weight Design
	Reinforced Shaft OR High Torque		Breather
	90° Breather		Mounting Feet
	Shaft Cover		Stainless Steel
	Submersible		Corrosion Protection
	Nuclear Rated		Food Grade
	Low Temperature		High Temperature

### 2 Way Hollow Shaft

C370H20-10

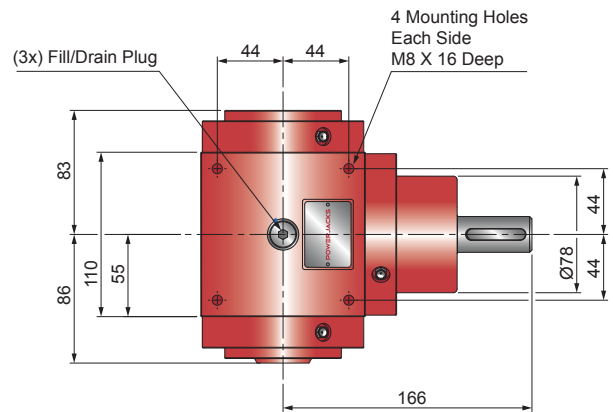

Tapped hole in end of each solid drive shaft - M8 x 25mm Deep

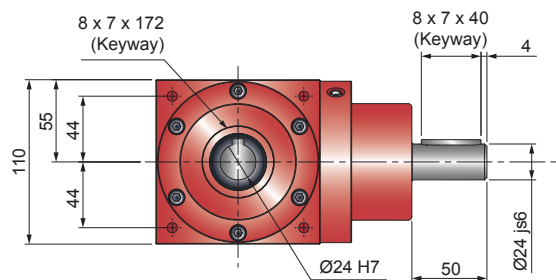

**Notes:**

1. All dimensions in mm unless otherwise stated
2. Dimensions subject to change without notice



### 3 Way Hollow Shaft

C370H30-10

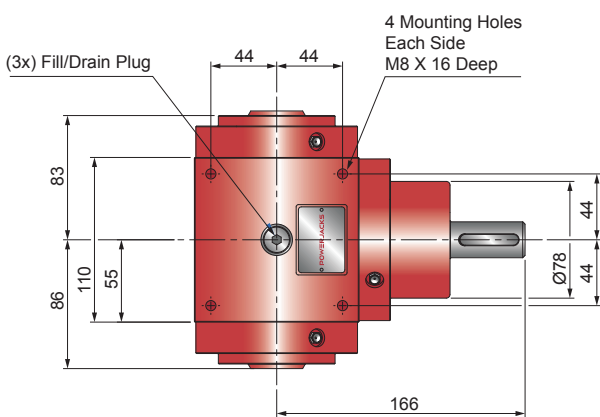

Tapped hole in end of each solid drive shaft - M8 x 25mm Deep

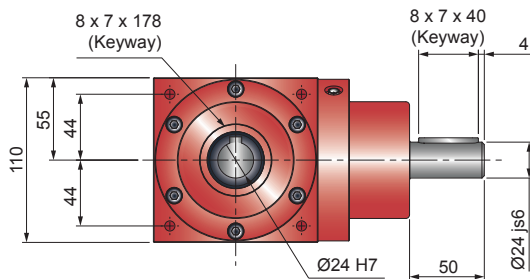

Notes:

1. All dimensions in mm unless otherwise stated
2. Dimensions subject to change without notice

### 4 Way Hollow Shaft

C370H40-10

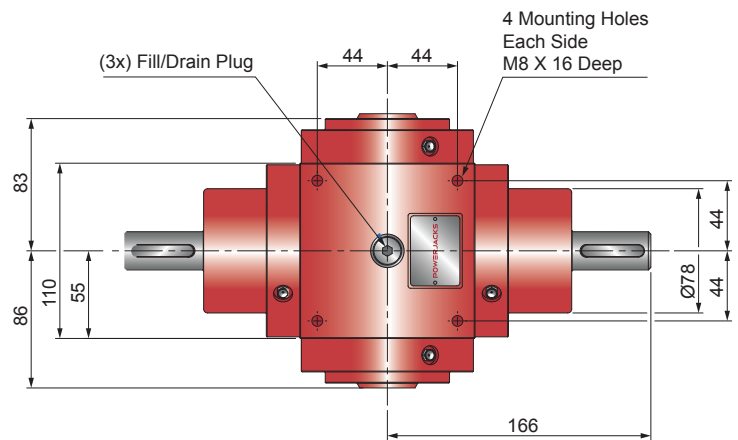

Tapped hole in end of each solid drive shaft - M8 x 25mm Deep

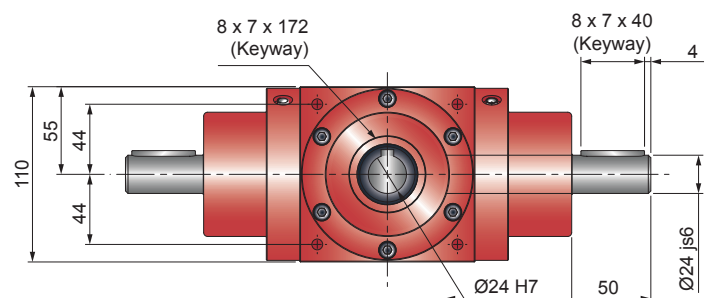

Notes:

1. All dimensions in mm unless otherwise stated
2. Dimensions subject to change without notice

### Performance

Series 38		
Torque (Nm)	Nominal#1	328
	Max Running#2	505
	Max Start-Up	758
Input Speed	Max [rpm]	3000
Thermal Limit	Power (kW)	20.5
Backlash	arcmin	9 to 16
Efficiency	(%)	95% - 98%
Service Life	(hours)	>10000
Housing Material		SG Iron
Oil Quantity	Litres	0.75
	Pints	1.32
Weight (kg)	2 Way - 1:1 & 1.5:1	21.75
	3 Way - 1:1 & 1.5:1	22
	4 Way - 1:1 & 1.5:1	25



















**Notes:**

#1 Nominal torque values at running speeds of 1500 rpm

#2 Maximum running torque value at speed of 10 rpm

Full detailed performance for each unit refer to page 16 & 17

### Accessories & Options

	Special Gear Ratio		Motor Flange
	Extended Drive Shaft		Limit Switches
	Drives		Light Weight Design
	Reinforced Shaft OR High Torque		Breather
	90° Breather		Mounting Feet
	Shaft Cover		Stainless Steel
	Submersible		Corrosion Protection
	Nuclear Rated		Food Grade
	Low Temperature		High Temperature

### 2 Way Solid Shaft

C380S20-10

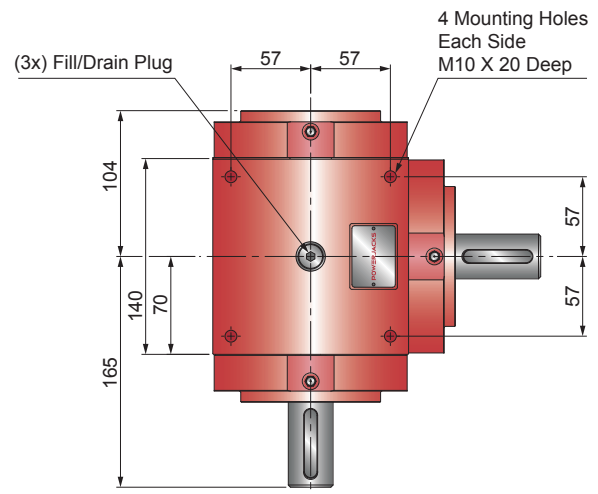

Tapped hole in end of each solid drive shaft - M10 x 25mm Deep

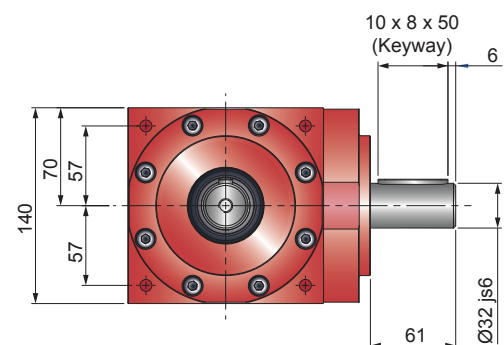

**Notes:**

1. All dimensions in mm unless otherwise stated
2. Dimensions subject to change without notice

### 3 Way Solid Shaft

C380S30-10

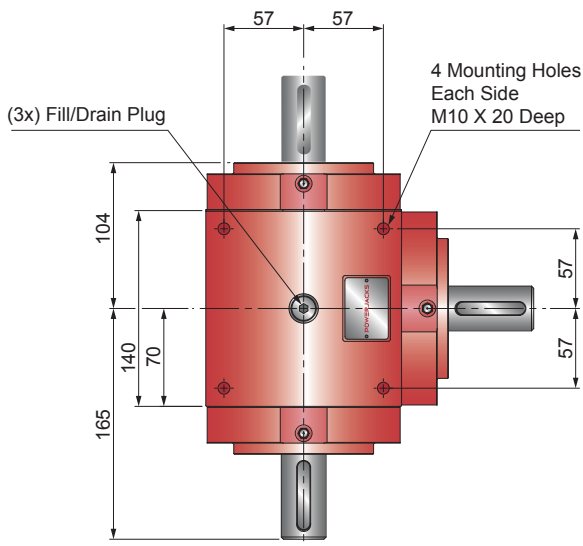

Tapped hole in end of each solid drive shaft - M10 x 25mm Deep

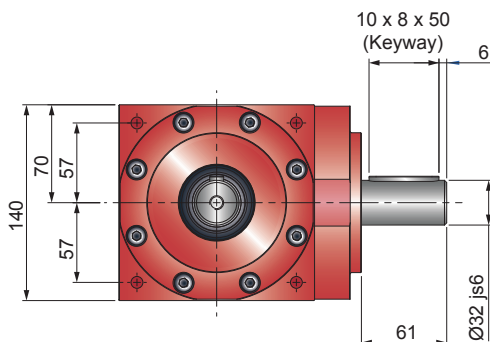

Notes:

1. All dimensions in mm unless otherwise stated
2. Dimensions subject to change without notice

### 4 Way Solid Shaft

C380S40-10

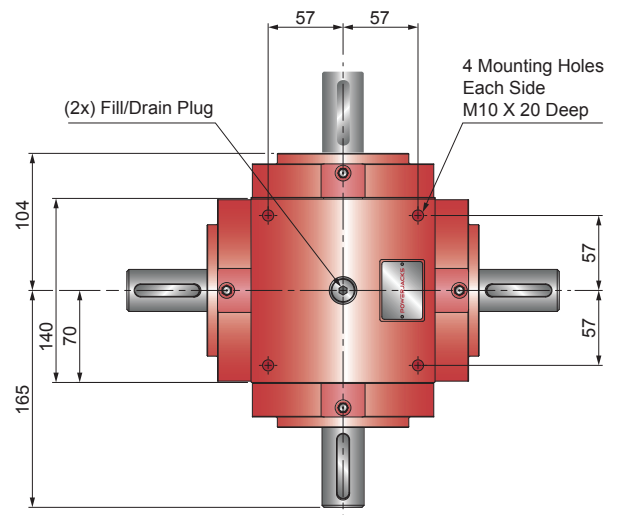

Tapped hole in end of each solid drive shaft - M10 x 25mm Deep

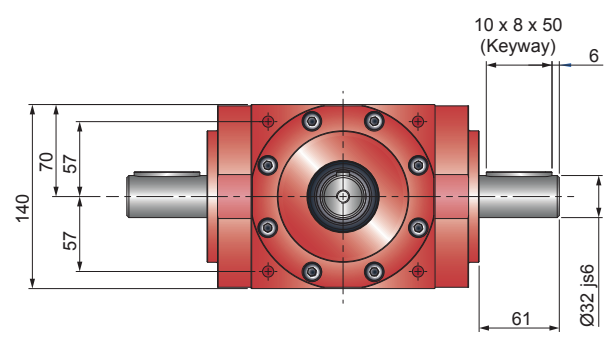

Notes:

1. All dimensions in mm unless otherwise stated
2. Dimensions subject to change without notice

### Performance

Series 38		
Torque (Nm)	Nominal#1	328
	Max Running#2	505
	Max Start-Up	758
Input Speed	Max (rpm)	3000
Thermal Limit	Power (kW)	20.5
Backlash	arcmin	9 to 16
Efficiency	(%)	95% - 98%
Service Life	(hours)	>10000
Housing Material		SG Iron
Oil Quantity	Litres	0.75
	Pints	1.32
Weight (kg)	2 Way - 2:1 +	21
	3 Way - 2:1 +	22.5
	4 Way - 2:1 +	27



















**Notes:**

#1 Nominal torque values at running speeds of 1500 rpm

#2 Maximum running torque value at speed of 10 rpm

Full detailed performance for each unit refer to page 16 & 17

### Accessories & Options

	Special Gear Ratio		Motor Flange
	Extended Drive Shaft		Limit Switches
	Drives		Light Weight Design
	Reinforced Shaft OR High Torque		Breather
	90° Breather		Mounting Feet
	Shaft Cover		Stainless Steel
	Submersible		Corrosion Protection
	Nuclear Rated		Food Grade
	Low Temperature		High Temperature

### 2 Way Solid Shaft

C380S20-20

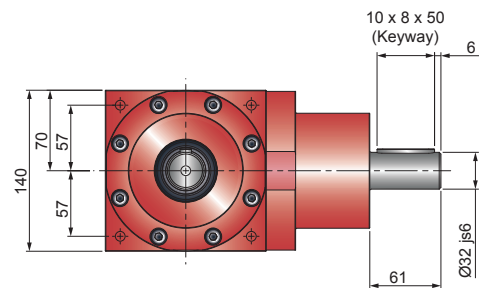
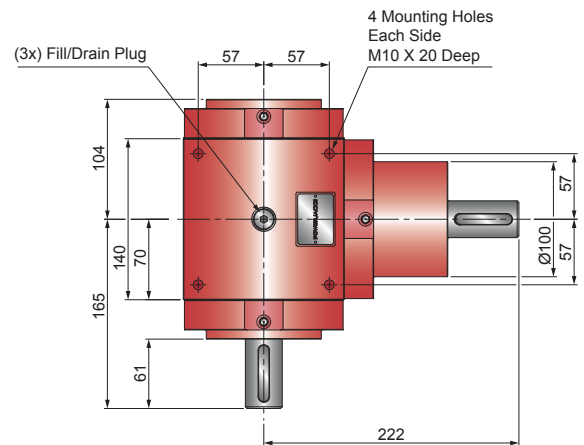
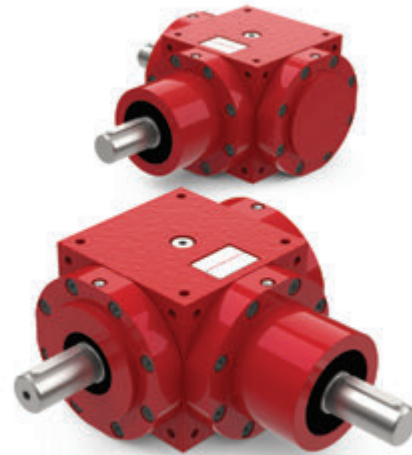

**Notes:**

1. All dimensions in mm unless otherwise stated
2. Dimensions subject to change without notice

### 3 Way Solid Shaft

C380S30-20

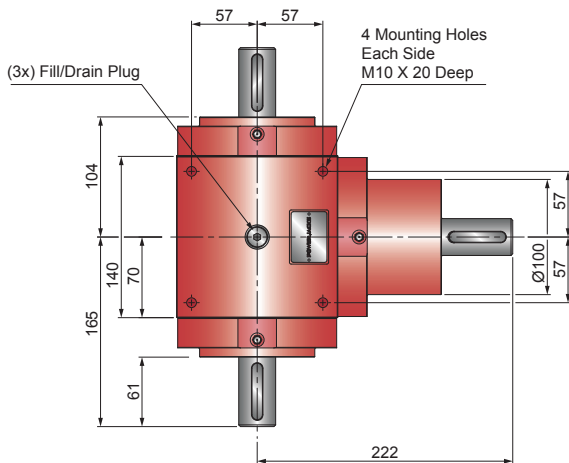

Tapped hole in end of each solid drive shaft - M10 x 25mm Deep

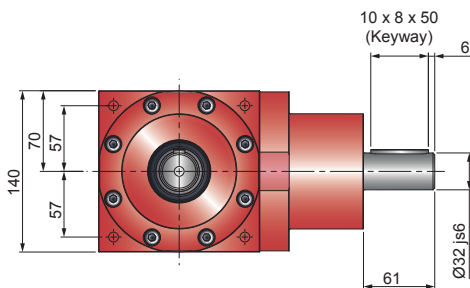

Notes:

1. All dimensions in mm unless otherwise stated
2. Dimensions subject to change without notice

### 4 Way Solid Shaft

C380S40-20

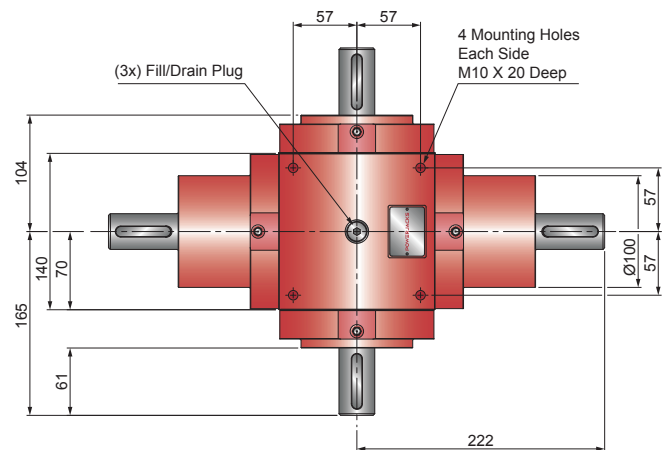

Tapped hole in end of each solid drive shaft - M10 x 25mm Deep

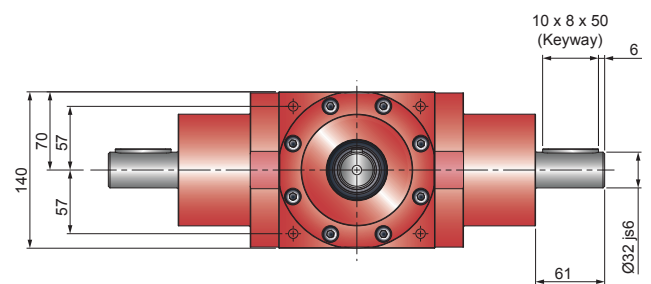

Notes:

1. All dimensions in mm unless otherwise stated
2. Dimensions subject to change without notice

### Performance

Series 38		
Torque (Nm)	Nominal#1	328
	Max Running#2	505
	Max Start-Up	758
Input Speed	Max (rpm)	3000
Thermal Limit	Power (kW)	20.5
Backlash	arcmin	9 to 16
Efficiency	(%)	95% - 98%
Service Life	(hours)	>10000
Housing Material		SG Iron
Oil Quantity	Litres	0.75
	Pints	1.32
Weight (kg)	2 Way - 1:1 & 1.5:1	21.75
	2 Way - 2:1 +	22
	3 Way - 1:1 & 1.5:1	22
	3 Way - 2:1 +	22.5
	4 Way - 1:1 & 1.5:1	25
	4 Way - 2:1 +	27



















**Notes:**

#1 Nominal torque values at running speeds of 1500 rpm

#2 Maximum running torque value at speed of 10 rpm

Full detailed performance for each unit refer to page 16 & 17

### Accessories & Options

	Special Gear Ratio		Motor Flange
	Extended Drive Shaft		Limit Switches
	Drives		Light Weight Design
	Reinforced Shaft OR High Torque		Breather
	90° Breather		Mounting Feet
	Shaft Cover		Stainless Steel
	Submersible		Corrosion Protection
	Nuclear Rated		Food Grade
	Low Temperature		High Temperature

### 2 Way Hollow Shaft

C380H20-10

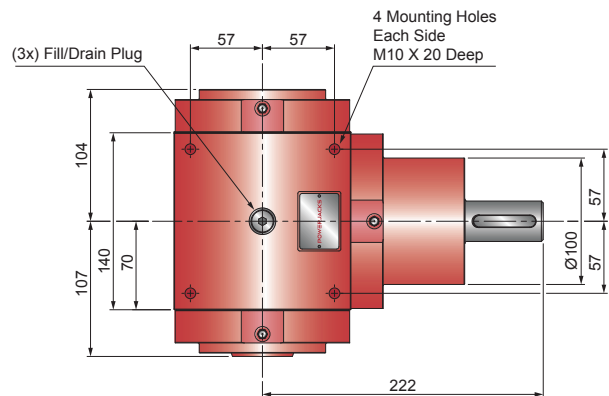

Tapped hole in end of each solid drive shaft - M10 x 25mm Deep

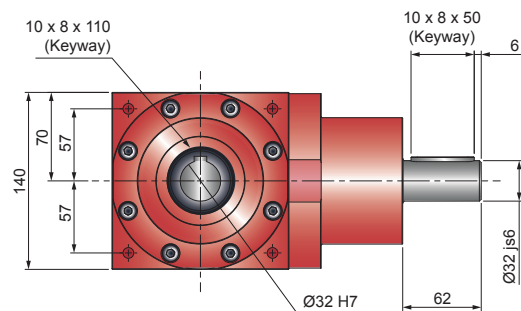

**Notes:**

1. All dimensions in mm unless otherwise stated
2. Dimensions subject to change without notice

### 3 Way Hollow Shaft

C380H30-10

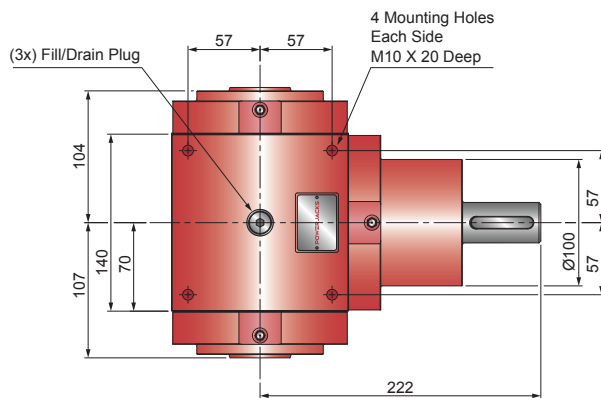

Tapped hole in end of each solid drive shaft - M10 x 25mm Deep

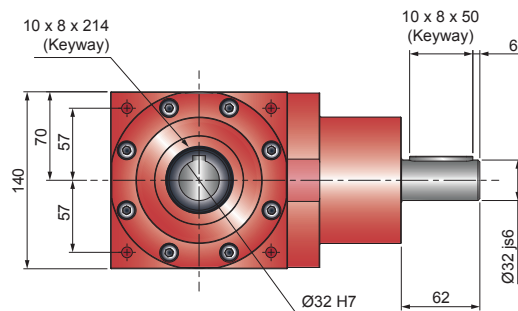

**Notes:**

1. All dimensions in mm unless otherwise stated
2. Dimensions subject to change without notice

### 4 Way Hollow Shaft

C380H40

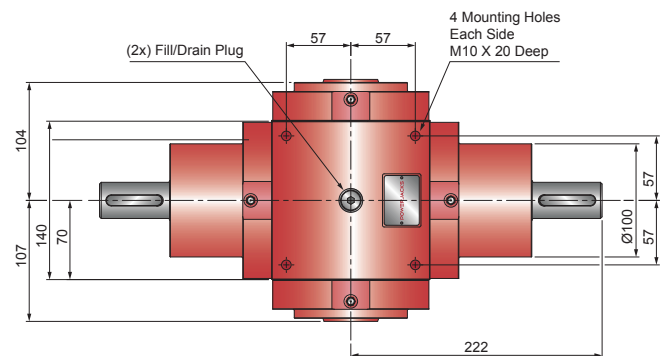

Tapped hole in end of each solid drive shaft - M10 x 25mm Deep

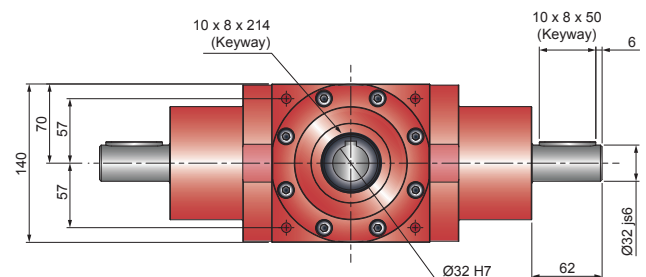

**Notes:**

1. All dimensions in mm unless otherwise stated
2. Dimensions subject to change without notice

### Performance

Series 39		
Torque (Nm)	Nominal#1	481
	Max Running#2	935
	Max Start-Up	1403
Input Speed	Max (rpm)	3000
Thermal Limit	Power (kW)	49
Backlash	arcmin	7 to 10
Efficiency	(%)	95% - 98%
Service Life	(hours)	>10000
Housing Material		SG Iron
Oil Quantity	Litres	1.71
	Pints	3
Weight (kg)	2 Way - 1:1 & 1.5:1	53.25
	3 Way - 1:1 & 1.5:1	54.5
	4 Way - 1:1 & 1.5:1	64



















**Notes:**

#1 Nominal torque values at running speeds of 1500 rpm

#2 Maximum running torque value at speed of 10 rpm

Full detailed performance for each unit refer to page 16 & 17

### Accessories & Options

	Special Gear Ratio		Motor Flange
	Extended Drive Shaft		Limit Switches
	Drives		Light Weight Design
	Reinforced Shaft OR High Torque		Breather
	90° Breather		Mounting Feet
	Shaft Cover		Stainless Steel
	Submersible		Corrosion Protection
	Nuclear Rated		Food Grade
	Low Temperature		High Temperature

### 2 Way Solid Shaft

C390S20-10

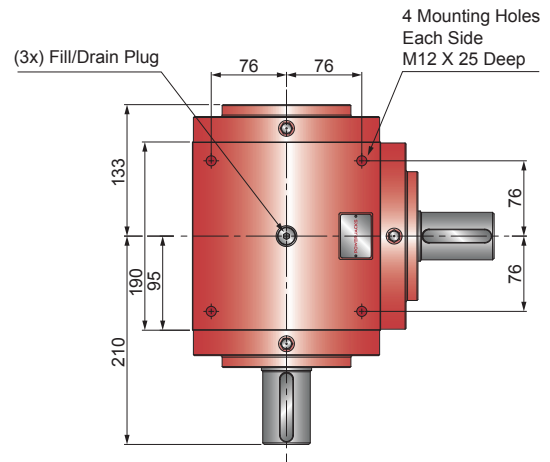

Tapped hole in end of each solid drive shaft - M12 x 30mm Deep

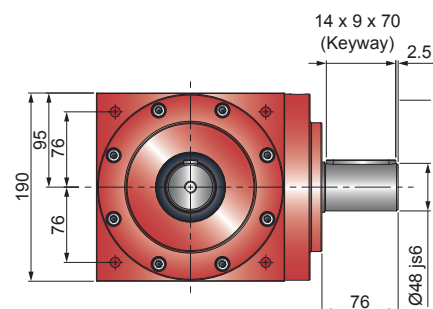

**Notes:**

1. All dimensions in mm unless otherwise stated
2. Dimensions subject to change without notice



### 3 Way Solid Shaft

C390S30-10

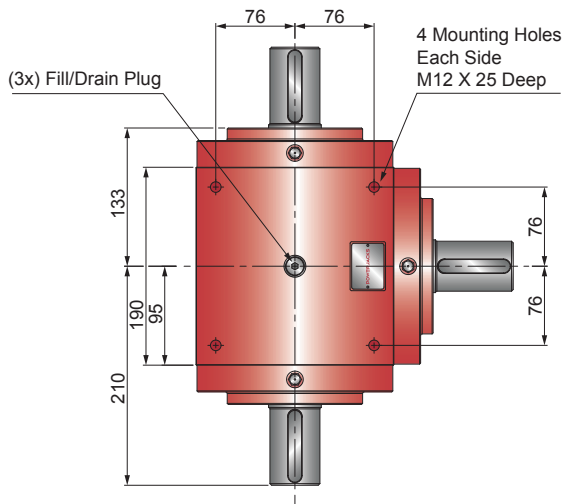
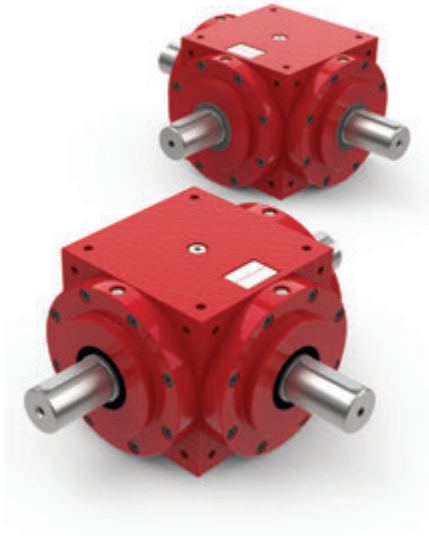

Tapped hole in end of each solid drive shaft - M12 x 30mm Deep

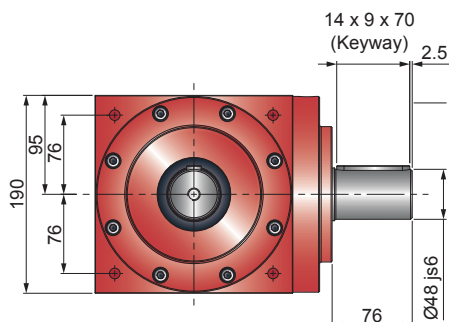

Notes:

1. All dimensions in mm unless otherwise stated
2. Dimensions subject to change without notice

### 4 Way Solid Shaft

C390S40-10

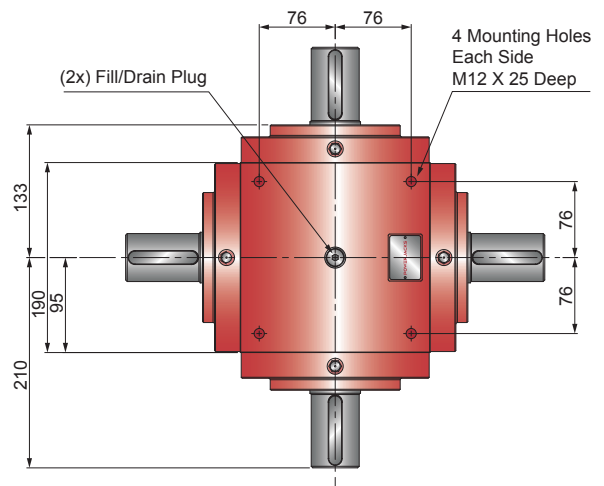

Tapped hole in end of each solid drive shaft - M12 x 30mm Deep

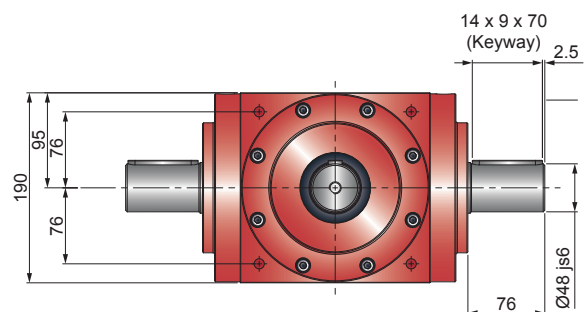

Notes:

1. All dimensions in mm unless otherwise stated
2. Dimensions subject to change without notice



















### Performance

Series 39		
Torque (Nm)	Nominal#1	481
	Max Running#2	935
	Max Start-Up	1403
Input Speed	Max (rpm)	3000
Thermal Limit	Power (kW)	49
Backlash	arcmin	7 to 10
Efficiency	(%)	95% - 98%
Service Life	(hours)	>10000
Housing Material		SG Iron
Oil Quantity	Litres	1.71
	Pints	3
Weight (kg)	2 Way - 2:1 +	54.5
	3 Way - 2:1 +	55.75
	4 Way - 2:1 +	69.5

**Notes:**

#1 Nominal torque values at running speeds of 1500 rpm  
 #2 Maximum running torque value at speed of 10 rpm  
 Full detailed performance for each unit refer to page 16 & 17

### Accessories & Options

	Special Gear Ratio		Motor Flange
	Extended Drive Shaft		Limit Switches
	Drives		Light Weight Design
	Reinforced Shaft OR High Torque		Breather
	90° Breather		Mounting Feet
	Shaft Cover		Stainless Steel
	Submersible		Corrosion Protection
	Nuclear Rated		Food Grade
	Low Temperature		High Temperature

### 2 Way Solid Shaft

C390S20-20

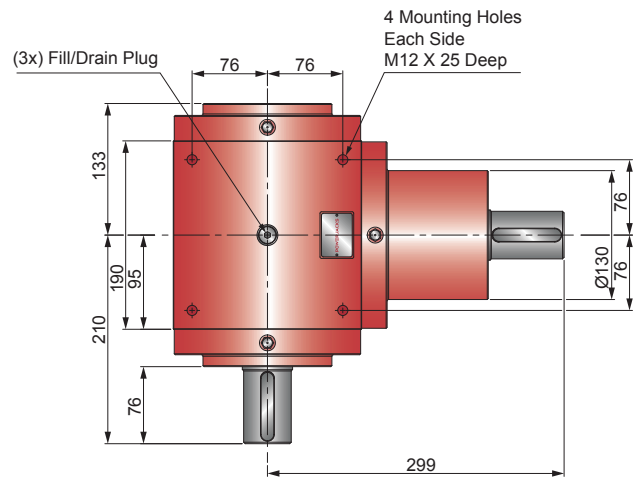
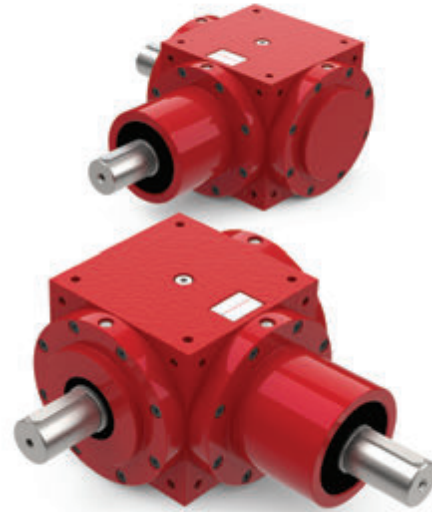

Tapped hole in end of each solid drive shaft - M12 x 30mm Deep

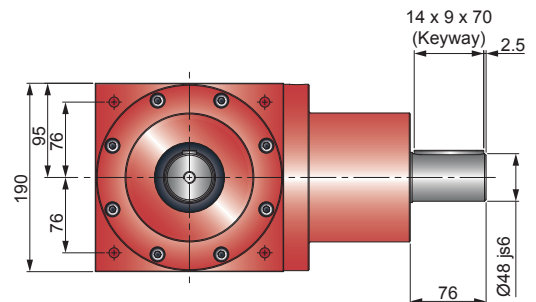

**Notes:**

1. All dimensions in mm unless otherwise stated
2. Dimensions subject to change without notice

### 3 Way Solid Shaft

C390S30-20

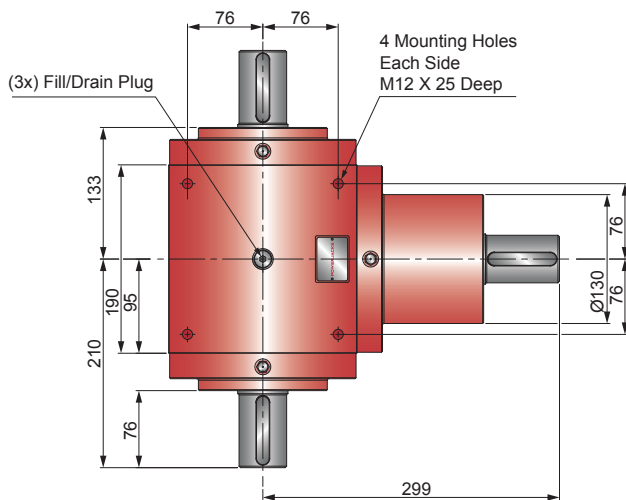

Tapped hole in end of each solid drive shaft - M12 x 30mm Deep

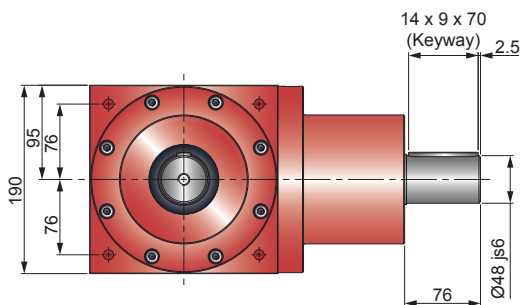

**Notes:**

1. All dimensions in mm unless otherwise stated
2. Dimensions subject to change without notice

### 4 Way Solid Shaft

C390S40-20

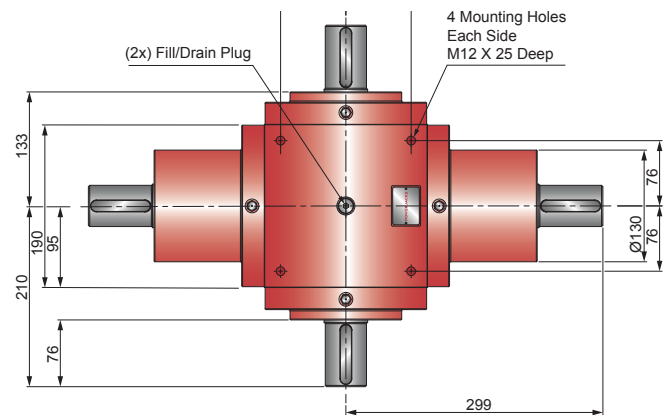

Tapped hole in end of each solid drive shaft - M12 x 30mm Deep

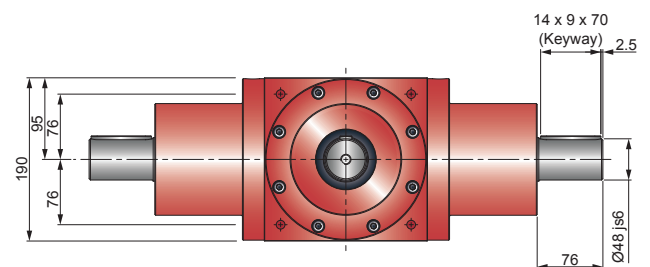

**Notes:**

1. All dimensions in mm unless otherwise stated
2. Dimensions subject to change without notice

Performance

Series 39		
Torque (Nm)	Nominal#1	481
	Max Running#2	935
	Max Start-Up	1403
Input Speed	Max (rpm)	3000
Thermal Limit	Power (kW)	49
Backlash	arcmin	7 to 10
Efficiency	(%)	95% - 98%
Service Life	(hours)	>10000
Housing Material		SG Iron
Oil Quantity	Litres	1.71
	Pints	3
Weight (kg)	2 Way - 1:1 & 1.5:1	53.25
	2 Way - 2:1 +	54.5
	3 Way - 1:1 & 1.5:1	54.5
	3 Way - 2:1 +	55.75
	4 Way - 1:1 & 1.5:1	64
	4 Way - 2:1 +	69.5



















Notes:

#1 Nominal torque values at running speeds of 1500 rpm

#2 Maximum running torque value at speed of 10 rpm

Full detailed performance for each unit refer to page 16 & 17

Accessories & Options

	Special Gear Ratio		Motor Flange
	Extended Drive Shaft		Limit Switches
	Drives		Light Weight Design
	Reinforced Shaft OR High Torque		Breather
	90° Breather		Mounting Feet
	Shaft Cover		Stainless Steel
	Submersible		Corrosion Protection
	Nuclear Rated		Food Grade
	Low Temperature		High Temperature

2 Way Hollow Shaft

C390H20-10

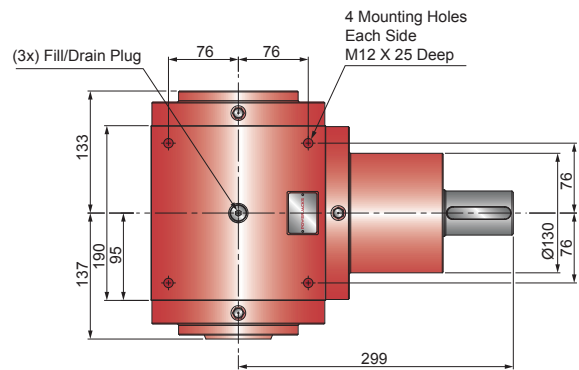

Tapped hole in end of each solid drive shaft - M12 x 30mm Deep

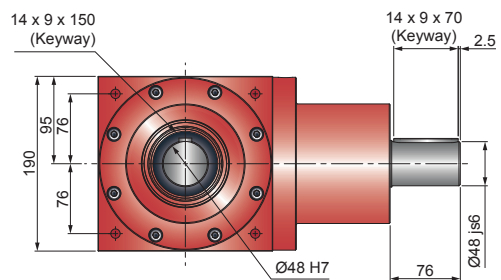

Notes:

1. All dimensions in mm unless otherwise stated
2. Dimensions subject to change without notice

### 3 Way Hollow Shaft

C390H30-10

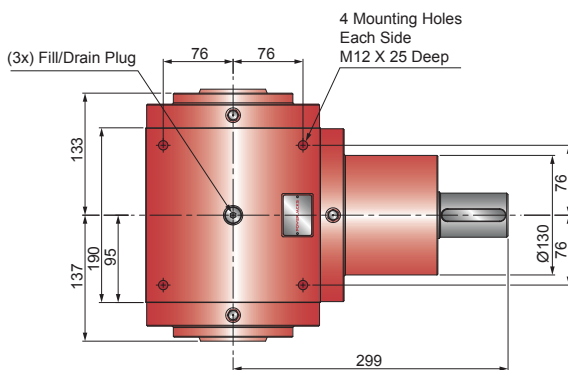

Tapped hole in end of each solid drive shaft - M12 x 30mm Deep

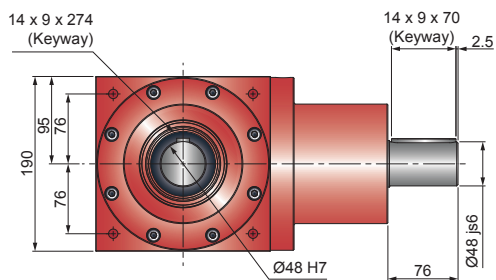

**Notes:**

1. All dimensions in mm unless otherwise stated
2. Dimensions subject to change without notice

### 4 Way Hollow Shaft

C390H40-10

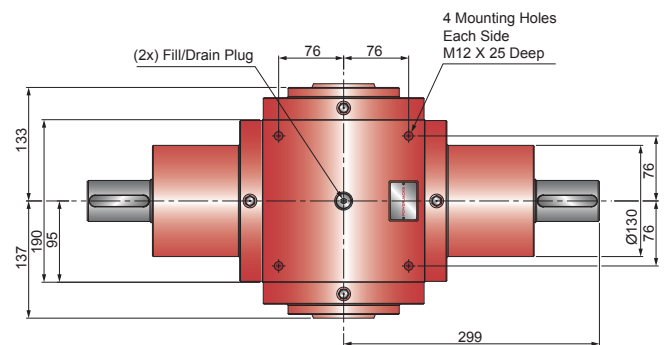

Tapped hole in end of each solid drive shaft - M12 x 30mm Deep

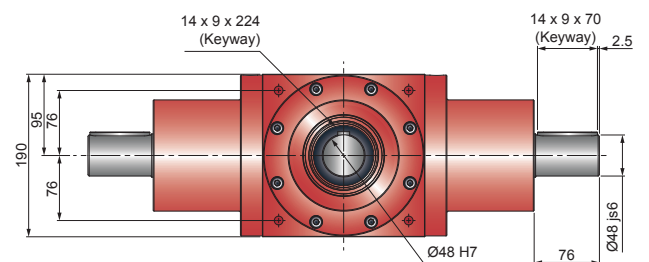

**Notes:**

1. All dimensions in mm unless otherwise stated
2. Dimensions subject to change without notice

### Performance

Series 40		
Torque (Nm)	Nominal#1	1353
	Max Running#2	3088
	Max Start-Up	4632
Input Speed	Max (rpm)	3000
Thermal Limit	Power (kW)	90
Backlash	arcmin	7 to 10
Efficiency	(%)	95% - 98%
Service Life	(hours)	>10000
Housing Material		SG Iron
Oil Quantity	Litres	3.27
	Pints	5.75
Weight (kg)	2 Way - 1:1 & 1.5:1	125
	3 Way - 1:1 & 1.5:1	128
	4 Way - 1:1 & 1.5:1	150



















**Notes:**

#1 Nominal torque values at running speeds of 1500 rpm

#2 Maximum running torque value at speed of 10 rpm

Full detailed performance for each unit refer to page 16 & 17

### Accessories & Options

	Special Gear Ratio		Motor Flange
	Extended Drive Shaft		Limit Switches
	Drives		Light Weight Design
	Reinforced Shaft OR High Torque		Breather
	90° Breather		Mounting Feet
	Shaft Cover		Stainless Steel
	Submersible		Corrosion Protection
	Nuclear Rated		Food Grade
	Low Temperature		High Temperature

### 2 Way Solid Shaft

C400S20-10

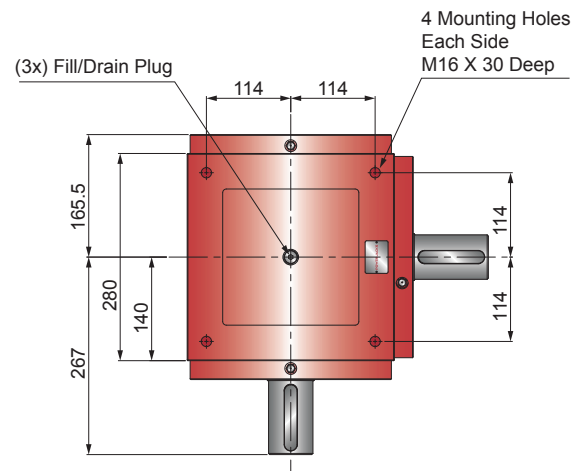
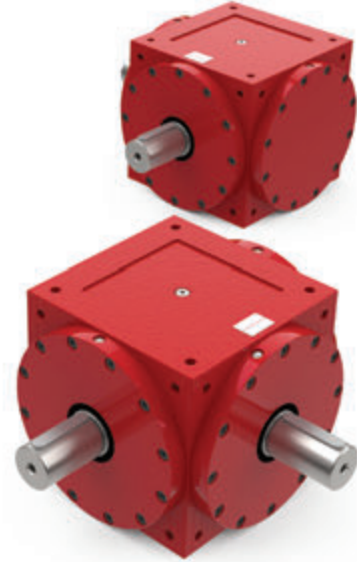

Tapped hole in end of each solid drive shaft - M16 x 38mm Deep

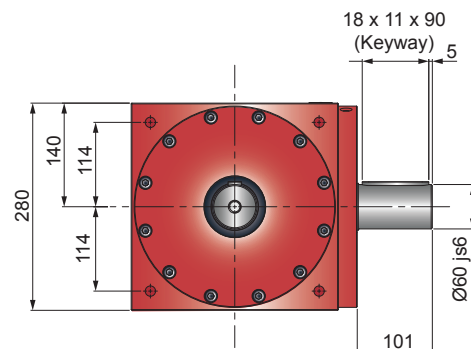

**Notes:**

1. All dimensions in mm unless otherwise stated
2. Dimensions subject to change without notice

### 3 Way Solid Shaft

C400S30-10

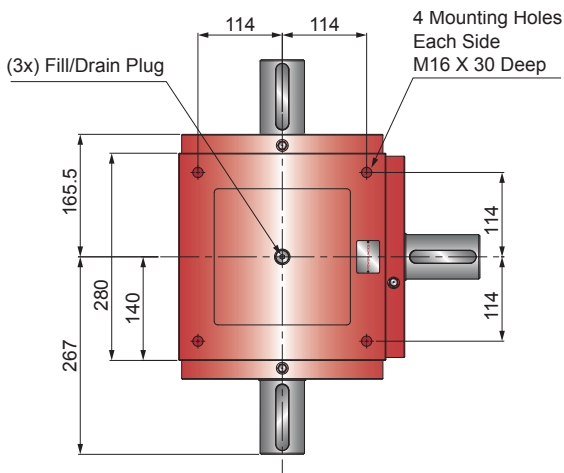
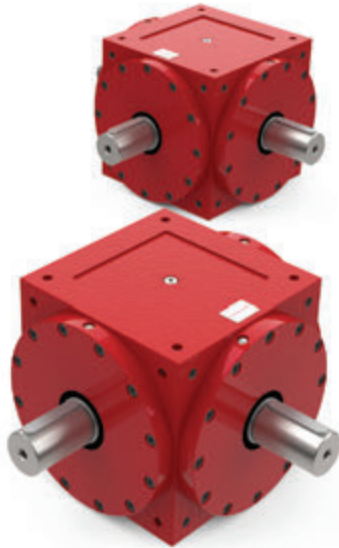

Tapped hole in end of each solid drive shaft - M16 x 38mm Deep

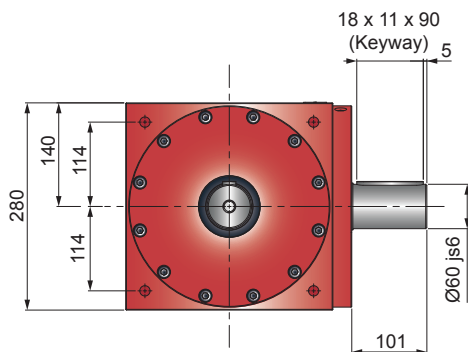

Notes:

1. All dimensions in mm unless otherwise stated
2. Dimensions subject to change without notice

### 4 Way Solid Shaft

C400S40-10

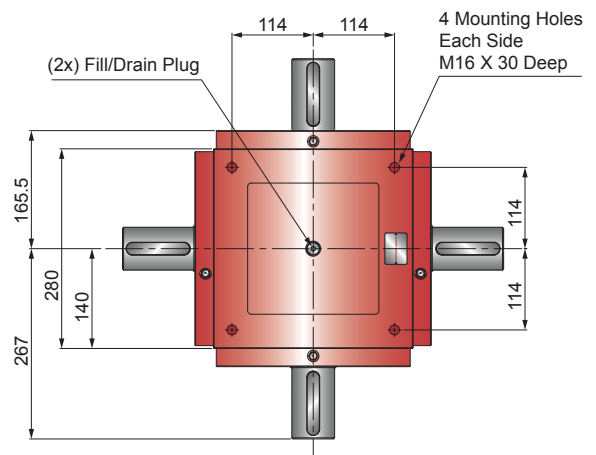

Tapped hole in end of each solid drive shaft - M16 x 38mm Deep

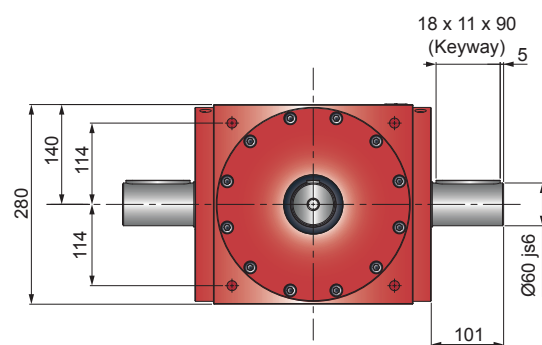

Notes:

1. All dimensions in mm unless otherwise stated
2. Dimensions subject to change without notice

### Performance

Series 40		
Torque (Nm)	Nominal#1	1353
	Max Running#2	3088
	Max Start-Up	4632
Input Speed	Max (rpm)	3000
Thermal Limit	Power (kW)	90
Backlash	arcmin	7 to 10
Efficiency	(%)	95% - 98%
Service Life	(hours)	>10000
Housing Material		SG Iron
Oil Quantity	Litres	3.27
	Pints	5.75
Weight (kg)	2 Way - 2:1 +	125
	3 Way - 2:1 +	128
	4 Way - 2:1 +	153



















**Notes:**

#1 Nominal torque values at running speeds of 1500 rpm

#2 Maximum running torque value at speed of 10 rpm

Full detailed performance for each unit refer to page 16 & 17

### Accessories & Options

	Special Gear Ratio		Motor Flange
	Extended Drive Shaft		Limit Switches
	Drives		Light Weight Design
	Reinforced Shaft OR High Torque		Breather
	90° Breather		Mounting Feet
	Shaft Cover		Stainless Steel
	Submersible		Corrosion Protection
	Nuclear Rated		Food Grade
	Low Temperature		High Temperature

### 2 Way Solid Shaft

C400S20-20

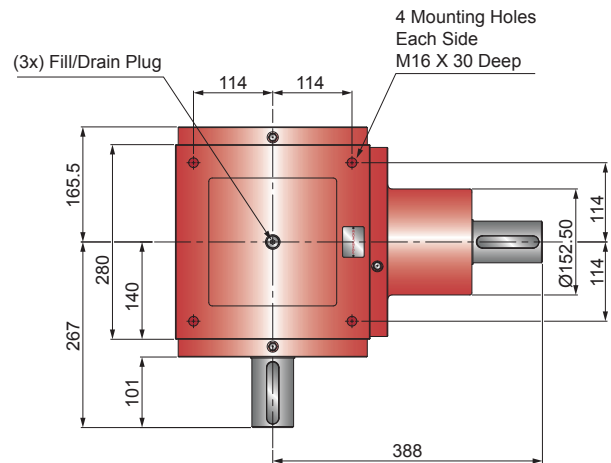

Tapped hole in end of each solid drive shaft - M16 x 38mm Deep

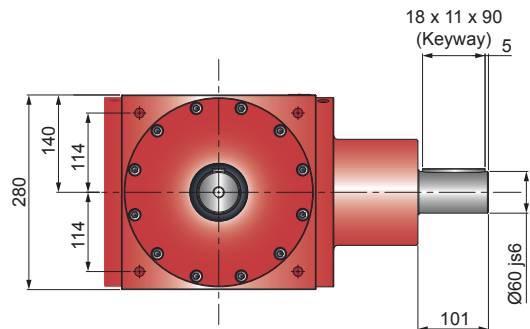

**Notes:**

1. All dimensions in mm unless otherwise stated
2. Dimensions subject to change without notice



### 3 Way Solid Shaft

C400S30-20

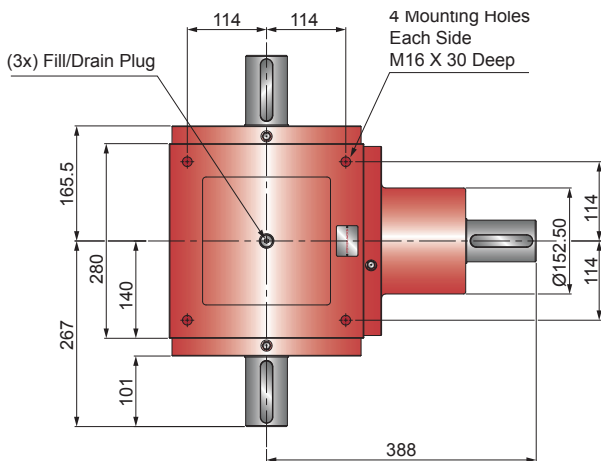
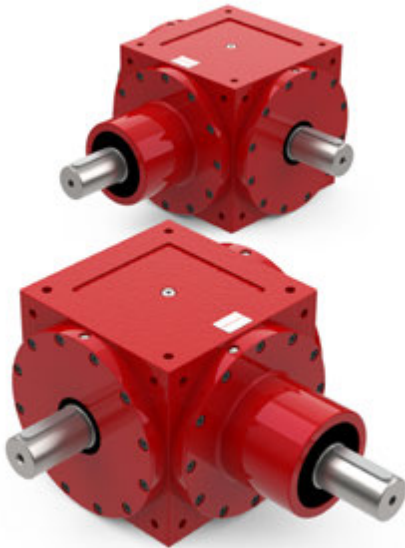

Tapped hole in end of each solid drive shaft - M16 x 38mm Deep

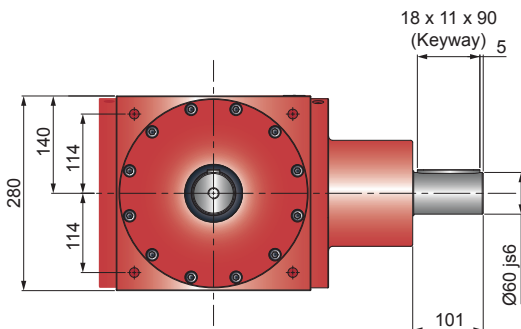

#### Notes:

1. All dimensions in mm unless otherwise stated
2. Dimensions subject to change without notice

### 4 Way Solid Shaft

C400S40-20

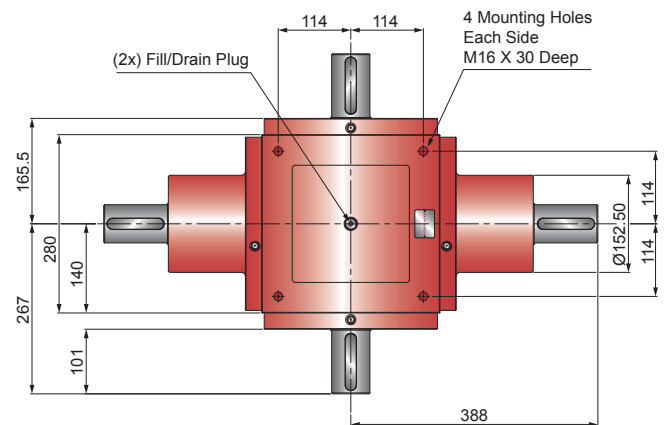

Tapped hole in end of each solid drive shaft - M16 x 38mm Deep

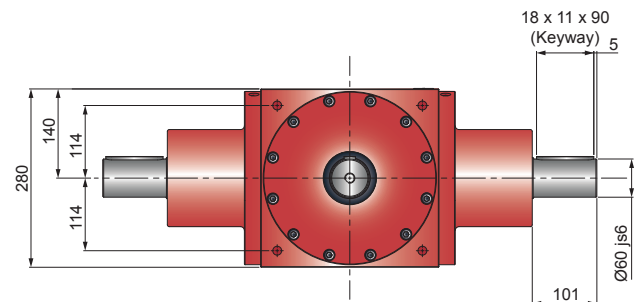

#### Notes:

1. All dimensions in mm unless otherwise stated
2. Dimensions subject to change without notice



















### Performance

Series 40		
Torque (Nm)	Nominal#1	1353
	Max Running#2	3088
	Max Start-Up	4632
Input Speed	Max (rpm)	3000
Thermal Limit	Power (kW)	90
Backlash	arcmin	7 to 10
Efficiency	(%)	95% - 98%
Service Life	(hours)	>10000
Housing Material		SG Iron
Oil Quantity	Litres	3.27
	Pints	5.75
Weight (kg)	2 Way - 1:1 & 1.5:1	125
	2 Way - 2:1 +	125
	3 Way - 1:1 & 1.5:1	128
	3 Way - 2:1 +	128
	4 Way - 1:1 & 1.5:1	150
	4 Way - 2:1 +	153

Notes:

- #1 Nominal torque values at running speeds of 1500 rpm
- #2 Maximum running torque value at speed of 10 rpm
- Full detailed performance for each unit refer to page 16 & 17

### Accessories & Options

	Special Gear Ratio		Motor Flange
	Extended Drive Shaft		Limit Switches
	Drives		Light Weight Design
	Reinforced Shaft OR High Torque		Breather
	90° Breather		Mounting Feet
	Shaft Cover		Stainless Steel
	Submersible		Corrosion Protection
	Nuclear Rated		Food Grade
	Low Temperature		High Temperature

### 2 Way Hollow Shaft

C400H20-10

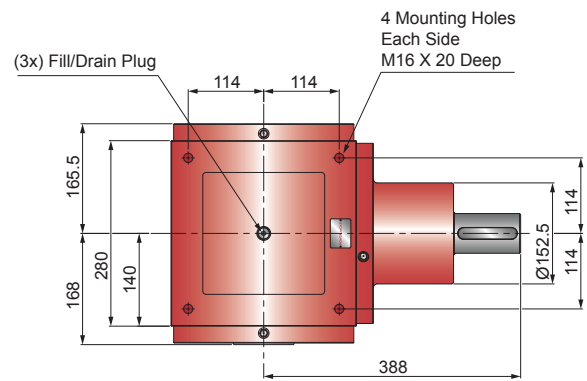

Tapped hole in end of each solid drive shaft - M16 x 38mm Deep

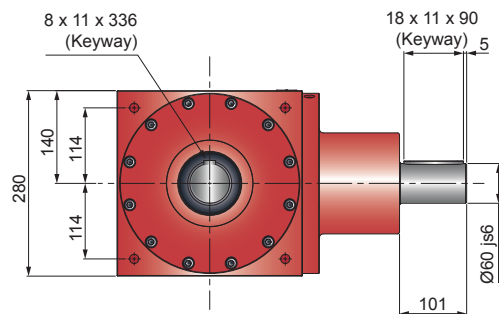

Notes:

1. All dimensions in mm unless otherwise stated
2. Dimensions subject to change without notice

### 3 Way Hollow Shaft

C400H30-10

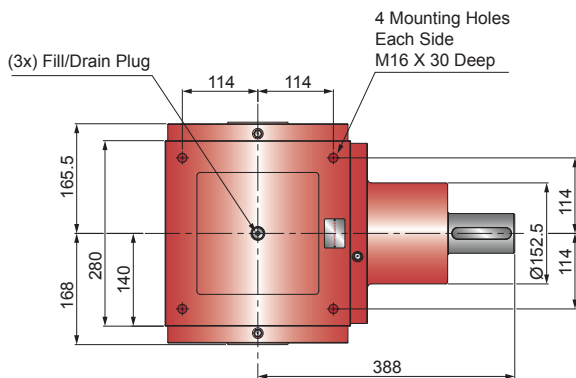

Tapped hole in end of each solid drive shaft - M16 x 38mm Deep

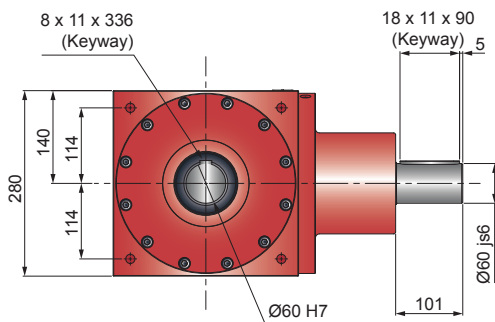

Notes:

1. All dimensions in mm unless otherwise stated
2. Dimensions subject to change without notice

### 4 Way Hollow Shaft

C400H40-10

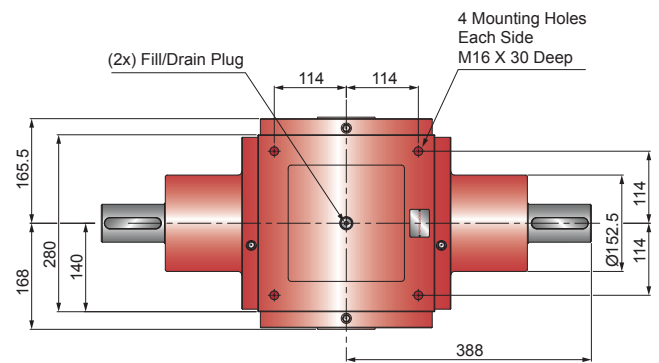

Tapped hole in end of each solid drive shaft - M16 x 38mm Deep

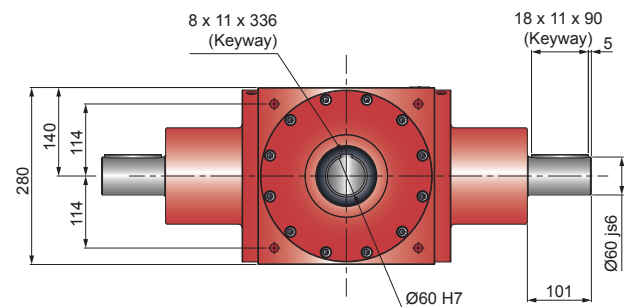

Notes:

1. All dimensions in mm unless otherwise stated
2. Dimensions subject to change without notice



















### Performance

Series 42		
Torque (Nm)	Nominal#1	6195
	Max Running#2	7000
	Max Start-Up	10500
Input Speed	Max (rpm)	3000
Thermal Limit	Power (kW)	190
Backlash	arcmin	7 to 10
Efficiency	(%)	95% - 98%
Service Life	(hours)	>10000
Housing Material		SG Iron
Oil Quantity	Litres	7
	Pints	12.3
Weight (kg)	2 Way - 1:1 & 1.5:1	190
	3 Way - 1:1 & 1.5:1	197
	4 Way - 1:1 & 1.5:1	204

**Notes:**

#1 Nominal torque values at running speeds of 1500 rpm  
 #2 Maximum running torque value at speed of 10 rpm  
 Full detailed performance for each unit refer to page 16 & 17

### Accessories & Options

	Special Gear Ratio		Motor Flange
	Extended Drive Shaft		Limit Switches
	Drives		Light Weight Design
	Reinforced Shaft OR High Torque		Breather
	90° Breather		Mounting Feet
	Shaft Cover		Stainless Steel
	Submersible		Corrosion Protection
	Nuclear Rated		Food Grade
	Low Temperature		High Temperature

### 2 Way Solid Shaft

N420S20-10

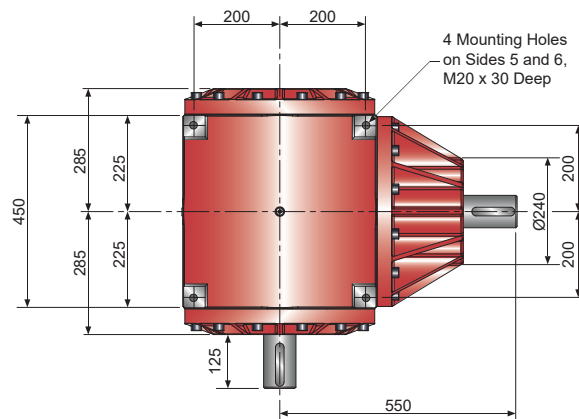

Tapped hole in end of each solid drive shaft - M16 x 38mm Deep

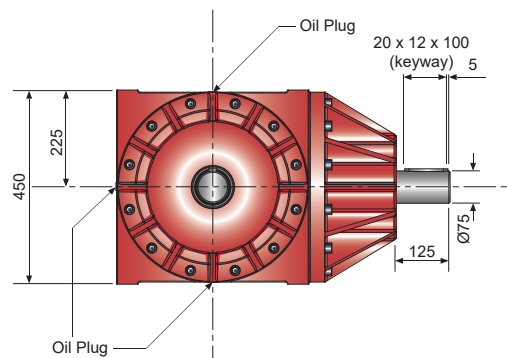

**Notes:**

1. All dimensions in mm unless otherwise stated
2. Dimensions subject to change without notice

## 3 Way Solid Shaft

N420S30-10

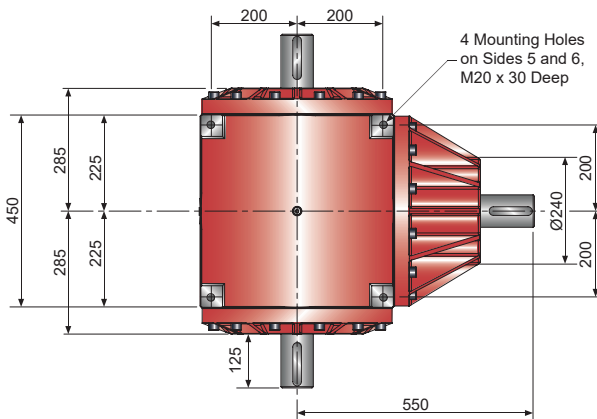

Tapped hole in end of each solid drive shaft - M16 x 38mm Deep

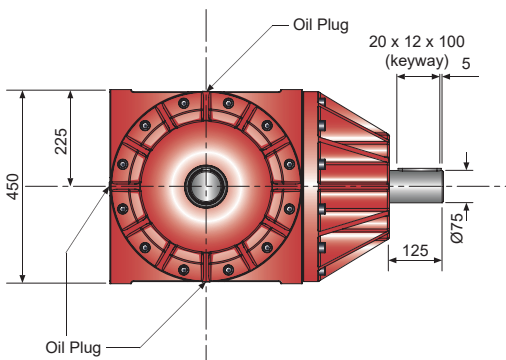

**Notes:**

1. All dimensions in mm unless otherwise stated
2. Dimensions subject to change without notice

## 4 Way Solid Shaft

N420S40-10

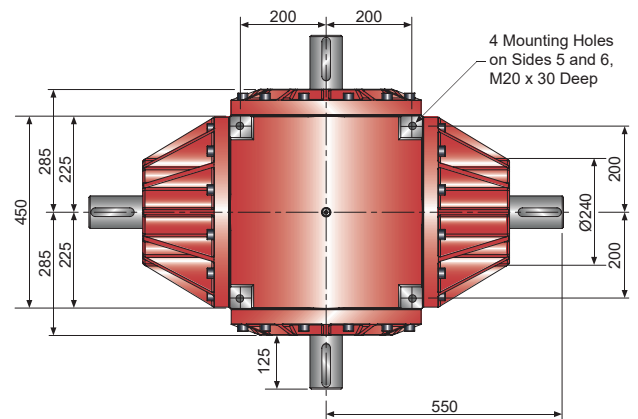

Tapped hole in end of each solid drive shaft - M16 x 38mm Deep

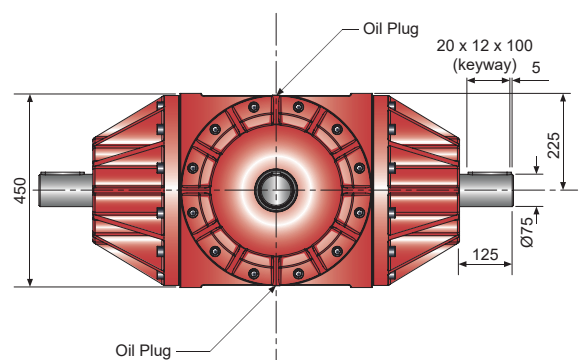

**Notes:**

1. All dimensions in mm unless otherwise stated
2. Dimensions subject to change without notice



















### Performance

Series 42		
Torque (Nm)	Nominal#1	6195
	Max Running#2	7000
	Max Start-Up	10500
Input Speed	Max (rpm)	3000
Thermal Limit	Power (kW)	190
Backlash	arcmin	7 to 10
Efficiency	(%)	95% - 98%
Service Life	(hours)	>10000
Housing Material		SG Iron
Oil Quantity	Litres	7
	Pints	12.3
Weight (kg)	2 Way - 2:1 +	215
	3 Way - 2:1 +	223
	4 Way - 2:1 +	231

**Notes:**

#1 Nominal torque values at running speeds of 1500 rpm  
 #2 Maximum running torque value at speed of 10 rpm  
 Full detailed performance for each unit refer to page 16 & 17

### Accessories & Options

	Special Gear Ratio		Motor Flange
	Extended Drive Shaft		Limit Switches
	Drives		Light Weight Design
	Reinforced Shaft OR High Torque		Breather
	90° Breather		Mounting Feet
	Shaft Cover		Stainless Steel
	Submersible		Corrosion Protection
	Nuclear Rated		Food Grade
	Low Temperature		High Temperature

### 2 Way Solid Shaft

N420S20-20

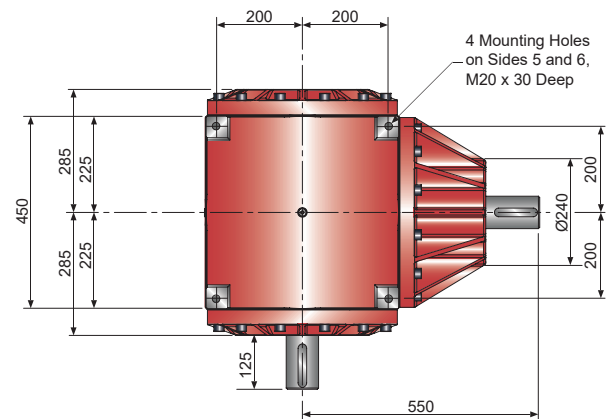

Tapped hole in end of each solid drive shaft - M16 x 38mm Deep

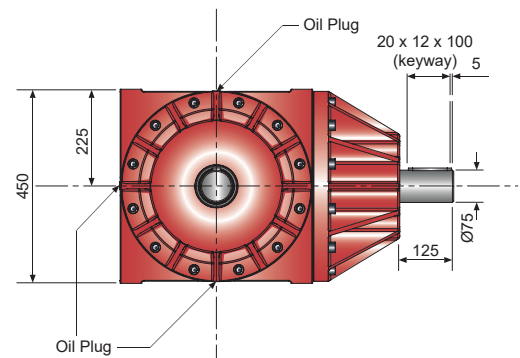

**Notes:**

1. All dimensions in mm unless otherwise stated
2. Dimensions subject to change without notice

### 3 Way Solid Shaft

N420S30-20

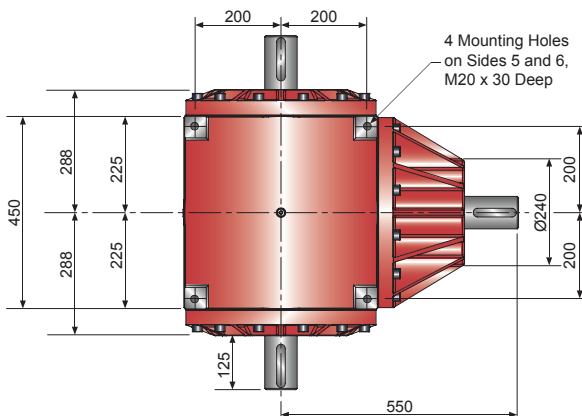

Tapped hole in end of each solid drive shaft - M16 x 38mm Deep

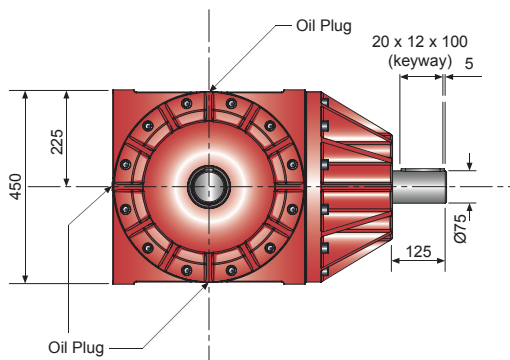

**Notes:**

1. All dimensions in mm unless otherwise stated
2. Dimensions subject to change without notice

### 4 Way Solid Shaft

N420S40-20

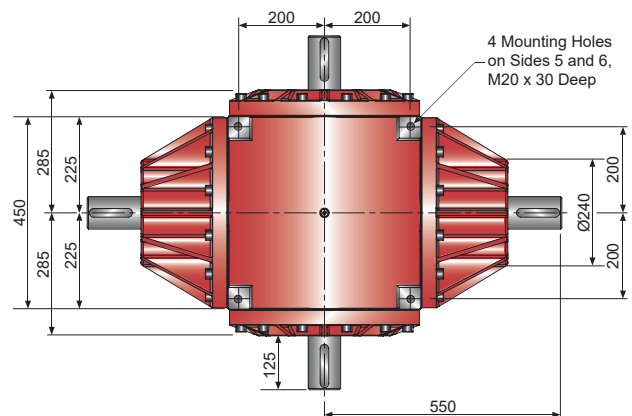

Tapped hole in end of each solid drive shaft - M16 x 38mm Deep

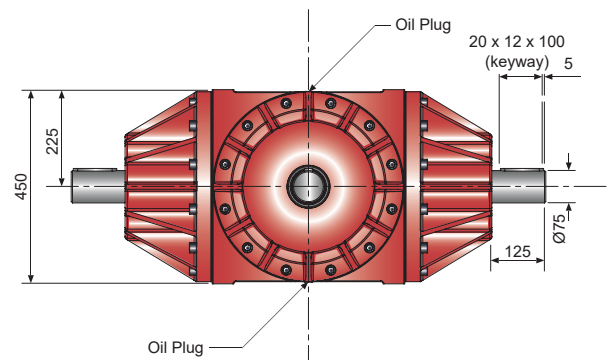

**Notes:**

1. All dimensions in mm unless otherwise stated
2. Dimensions subject to change without notice

Performance

Series 42		
Torque (Nm)	Nominal#1	6195
	Max Running#2	7000
	Max Start-Up	10500
Input Speed	Max (rpm)	3000
Thermal Limit	Power (kW)	190
Backlash	arcmin	7 to 10
Efficiency	(%)	95% - 98%
Service Life	(hours)	>10000
Housing Material		SG Iron
Oil Quantity	Litres	7
	Pints	12.3
Weight (kg)	2 Way - 1:1 & 1.5:1	190
	2 Way - 2:1 +	215
	3 Way - 1:1 & 1.5:1	197
	3 Way - 2:1 +	223
	4 Way - 1:1 & 1.5:1	204
	4 Way - 2:1 +	231



















Notes:

#1 Nominal torque values at running speeds of 1500 rpm

#2 Maximum running torque value at speed of 10 rpm

Full detailed performance for each unit refer to page 16 & 17

Accessories & Options

	Special Gear Ratio		Motor Flange
	Extended Drive Shaft		Limit Switches
	Drives		Light Weight Design
	Reinforced Shaft OR High Torque		Breather
	90° Breather		Mounting Feet
	Shaft Cover		Stainless Steel
	Submersible		Corrosion Protection
	Nuclear Rated		Food Grade
	Low Temperature		High Temperature

2 Way Hollow Shaft

N420H020-10

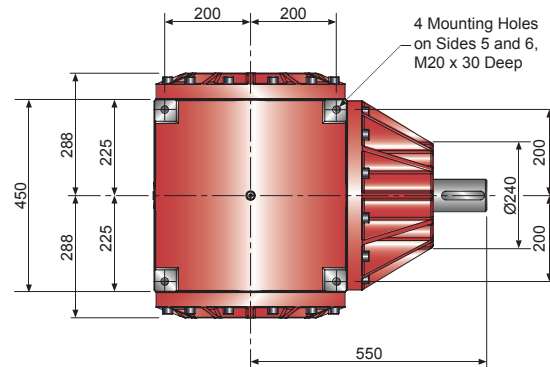

Tapped hole in end of each solid drive shaft - M16 x 38mm Deep

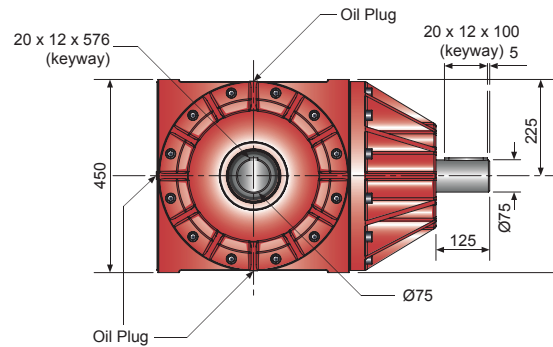

Notes:

1. All dimensions in mm unless otherwise stated
2. Dimensions subject to change without notice



### 3 Way Hollow Shaft

N420H030-10

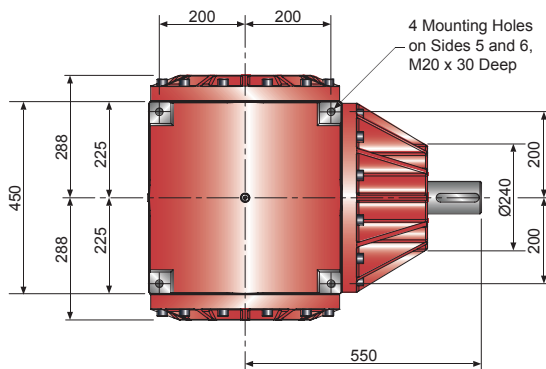

Tapped hole in end of each solid drive shaft - M16 x 38mm Deep

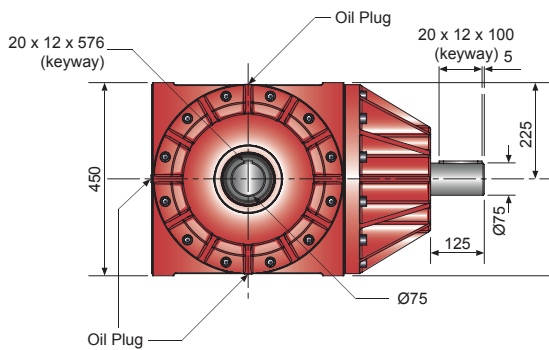

**Notes:**

1. All dimensions in mm unless otherwise stated
2. Dimensions subject to change without notice

### 4 Way Hollow Shaft

N420H040-10

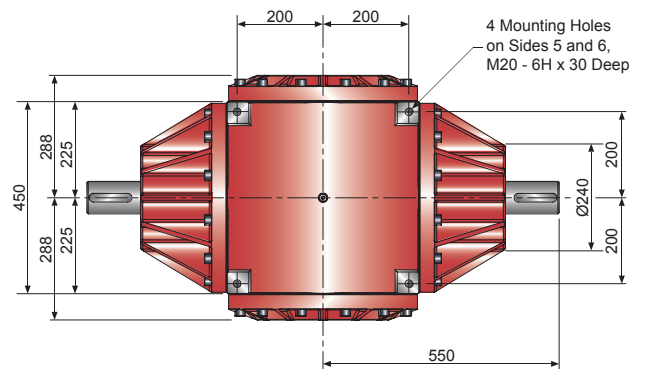

Tapped hole in end of each solid drive shaft - M16 x 38mm Deep

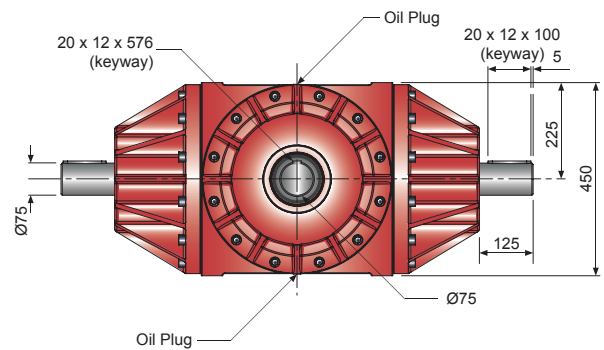

**Notes:**

1. All dimensions in mm unless otherwise stated
2. Dimensions subject to change without notice

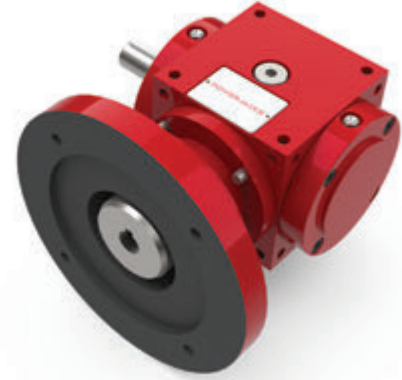
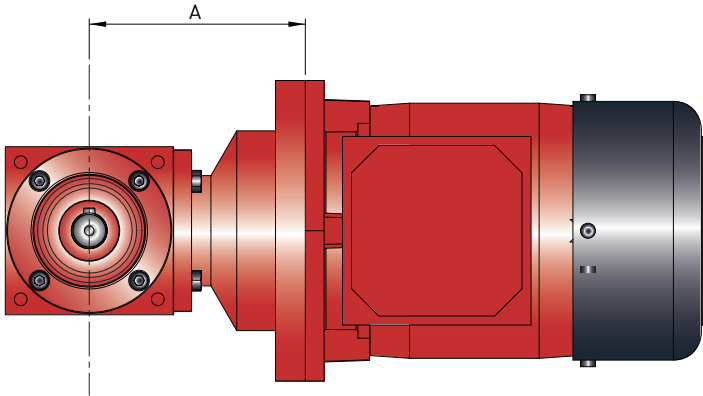

Motor frame Size B5 Flange	Gear unit Series	Gear Ratio	Dimension 'A'	Gear Unit Prefix for Product Code
71	35	All	115	A
80	35	All	115	B
90	37	All	130	C
100	37	1:1 & 1.5:1	130	D
100	37	2:1	140	D
112	37	1:1 & 1.5:1	130	D
112	37	2:1	140	D
112	38	All	190	D
132	38	All	190	E
132	39	All	220	E
160	38	1:1, 1.5:1 & 2:1	190	F
160	38	3:1 & 4:1	210	F
160	39	1:1, 1.5:1 & 2:1	220	F
160	39	3:1 & 4:1	240	F
180	39	1:1, 1.5:1 & 2:1	220	G
180	39	3:1 & 4:1	240	G
180	40	All	280	G
200	40	All	280	H
225 : 2 Pole	40	All	280	J
225 : 4-8 Pole	40	All	310	K
250 : 2 Pole	40	All	310	L

- Notes:
1. All standard motor adapters use a B5 IEC flange.
  2. All Flange dimensions conform to standard IEC electric motor details.
  3. NEMA flanges available on request.

## Extended Drive Shafts

---



For each gearbox size the drive shafts (input or output) can be extended in length for solid shaft or hollow shaft designs.

For an application these designs can:

- Eliminate the need for extra drives shafts.
- Reduce the number of couplings.
- Reduce the overall installation cost.
- Reduce the associated maintenance and spare parts inventory and cost.
- Allow the machine design to be fully optimised.

## Stainless Steel Bevel Gearboxes

---



Stainless steel gearboxes are recommended for use in applications which require one or more of the following properties:

- High corrosion resistance.
- Hygienic for food processing.
- Good chemical resistance.
- Resistance to fire & high temperatures.
- Strength at low temperatures.
- Stainless steel has good recycling options.
- Easy to clean surfaces.
- Non-magnetic options available.

All of which makes stainless steel gearboxes ideally suitable for industries such as marine, paper, chemical, food, beverage, nuclear, oil and gas.

## U-Series Underwater / Subsea Gearbox

The U-Series subsea bevel gearboxes are a proven and reliable technology for subsea drive solutions down to a depth of 3000m. They are used in a wide variety of underwater applications in the oil & gas and even the nuclear sector. Each submersible variant is tailored exactly to the customer application.



### Subsea Design Features

- Proven depth ratings up to 3000m subsea (deeper on request)
- Pressure compensated or flooded designs available
- Full stainless steel designs available
- Reinforced sealing
- Full range of anti-corrosion options
- ROV drive interfaces
- Low [-65°C) to High (+250°C) temperature solutions available
- Vibration and shock load resistant designs
- Full range of feedback devices for speed, position and rotation
- Special custom designs available to meet your exact requirements

### Standard Gearbox

- Six gearbox sizes
- 35, 37, 38, 39, 40, 42 Series
- Nine gearbox configurations
- Gear ratios: 1:1, 1.5:1, 2:1, 3:1, 4:1 as standard
- Special gear ratios available on request, e.g. 1.25:1
- Torque ratings up to 20000 Nm
- Option for reinforced shaft design for up to 300% higher torque transmission

### Reliable Spiral Bevel Gear

With a proven design already used in millions of gearboxes, the Precision Spiral Bevel Gears, with accurate gear mesh, deliver high torque with smooth and quiet transmission.



### Shaft Configurations

- 2, 3 or 4-way
- Solid or hollow shaft
- Special configurations available
- ROV torque receptacle integrated to gearbox drive
- ROV paddle adapter fitted to input drive shaft
- Motor adapter for direct connection of subsea motor to gearbox input
- Service life of 10,000 hours for all gearbox sizes
- Input speed up to 3,000 rpm maximum

### Gearbox Housing

A rugged compact design made from a highly durable SG iron as standard or stainless steel on request.

It provides a strong housing that firmly and accurately holds the gear set in a reservoir of quality lubricant suited to the demands of subsea work.

### Corrosion Protection



- To suit all economic needs
- Standard subsea paint finish
- Customer specified paint
- Plated finish
- Stainless steel

For more details request the U-Series brochure from Power Jacks or download a copy from [www.powerjacks.com](http://www.powerjacks.com)

## Design Possibilities / Designed For You

---

The Range-N bevel gearboxes are provided as a range of standard bevel gearboxes and as a range of engineered gearboxes. Each gearbox design can be altered to suit exact application requirements such as:

- Low weight designs.
- Long or short drive shafts.
- Keyless shafts.
- Shafts with threaded sections.
- Alternative shaft profiles e.g. hexagonal.
- Nuclear rated gearboxes.
- Food & beverage processing grade gearboxes.
- Special shaft sealing.
- Integrated or bolt on base flange.
- Extra mounting holes.
- Motor adapters for servo, hydraulic or air motors.
- Integrated limit switches.
- Protective shaft covers.
- High & low temperature rated designs.
- Alternative housing designs e.g. curved.
- High corrosion & chemical resistant designs.

Use Power Jacks engineering technology to bring your concept to reality.





Power Jacks specialises in the design and manufacture of precision linear actuation, positioning and lifting equipment.

Our products are supplied globally across many sectors including Industrial Automation, Energy, Transport, Defence and Civil.

Power Jacks Ltd  
Kingshill Commercial Park  
Prospect Road, Westhill  
Aberdeenshire AB32 6FP  
Scotland (UK)  
Tel: +44 (0)1224 968968

[www.powerjacks.com](http://www.powerjacks.com)  
[sales@powerjacks.com](mailto:sales@powerjacks.com)

PJBGB-C-EN-00a



All information in this document is subject to change without notice. All rights reserved by Power Jacks Limited.  
May not be copied in whole or in part. ©Power Jacks Limited 2024, Aberdeenshire, Scotland, United Kingdom.