

Q GUIDES **E-Series Machine Screw Jack**
Quick Guide to Operation & Maintenance

MMQG-SJ-EMS-EN-02

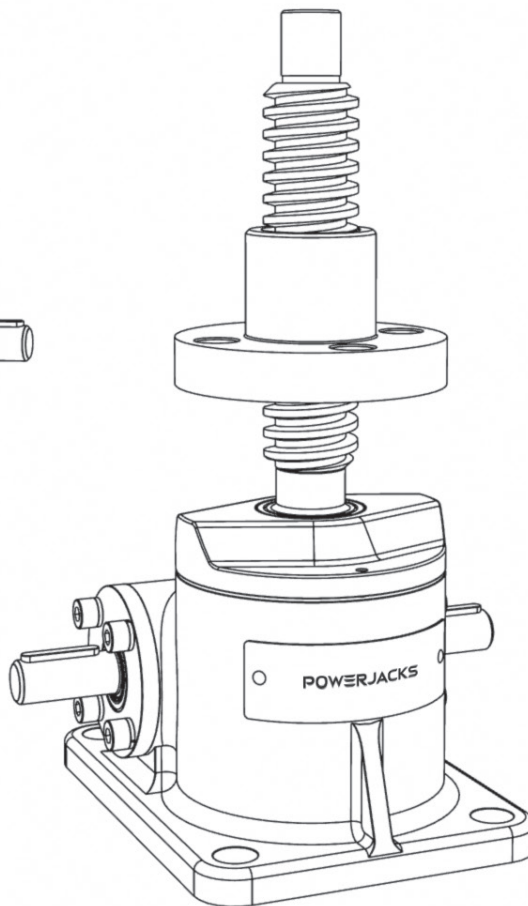
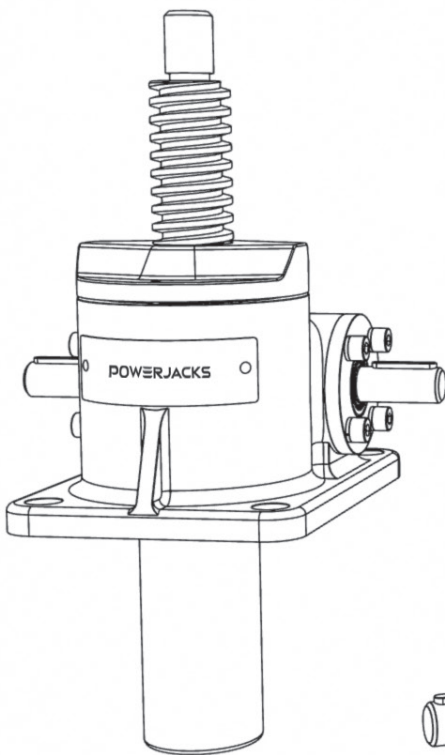

E-Series Machine Screw Jack

A full copy of the E-Series Operation and Maintenance manual can be downloaded at www.powerjacks.com/manuals. Alternatively a paper copy can be ordered from Power Jacks.

1-General

- 1.1 Before installing new parts, remove any rust preventative, protection grease etc.
- 1.2 Check before immediate installation for possible transit damage.
- 1.3 Components which have been stored for a long time (over 1 year) should be re-lubricated in working conditions before they are put into operation.
- 1.4 Before putting the E-Series screw jack(s) into service, the User must ensure that the plant in which it is installed complies with all applicable directives, especially those regarding health and safety at work.
- 1.5 Handle the screw jack with care. The E-Series screw jacks should be handled with care to avoid damaging the machined drive shafts and the threads of the lead screw.
- 1.6 Before putting the units into service, check the lubricant level. If necessary top up the lubricant to the required level.
- 1.7 Do not mix greases of different nature or specifications.
- 1.8 If the same type of grease already in use is not available, remove all of the existing lubricant completely and flush its interior thoroughly with a light solvent before refilling with a new lubricant.
- 1.9 The structure on which the E-Series screw jack(s) are mounted must have ample strength to carry the maximum load, and should be rigid enough to prevent undue deflection or distortion of the screw jack supporting members.
- 1.10 It is essential that the E-Series screw jack(s) be carefully aligned during installation so that the lead screw is running true and the connecting shafts are exactly in line with the input drive shafts.
- 1.11 When installing several screw jacks to move a common load/item/structure, the jacks should first be connected to the structure. The load should be equally distributed between the screw jacks. The screw jack input drive shafts should then be connected taking care not to turn the input shaft and lose the screw jack position relative to the structure.
- 1.12 After the E-Series screw jack(s) is installed, shafting, gearboxes, motors, etc., are coupled together it should be possible to turn the main drive by hand (no load on screw jack(s)). If there are no signs of binding or misalignment, the screw jack system is then ready for normal operation.
- 1.13 After the E-Series screw jack(s) are installed, they should be operated through their full travel four or five times under minimum load conditions. If the arrangement operates satisfactorily and there are no signs of binding or misalignment the E-Series screw jack(s) are ready for normal operation.
- 1.14 The screw jack should have a rated capacity greater than the maximum load that may be imposed on it.
- 1.15 The screw jacks should have a greater stroke than is needed in the actual installation. Should it be necessary to operate the screw jacks at the extreme limits of travel it should be done cautiously.
- 1.16 It is important that the lead screws should not be closed below the specified closed height dimension of the screw jacks, otherwise serious damage may result to the worm gear.
- 1.17 Lead screw end stops are to prevent over-travel or loss of screw. These are not load supporting and should

be treated as an emergency device only and must not be allowed to come into contact with the worm gears during normal working cycles otherwise serious damage will result to worm gears and bearings.

- 1.18 The maximum worm shaft speed for these screw jacks should not exceed 500 R.P.M. for heavy loads. Refer to Power Jacks Limited for higher worm shaft speeds for lighter loads. the input power should not exceed the power rating shown in the catalogues screw jack performance tables.
- 1.19 The lead screws should not be permitted to accumulate dust and grit on the threads. If possible, lead screws should be returned to the closed position (retracted) when not in use.
- 1.20 If equipped with bellows boot the boot must not be compressed below its minimum height (consult Power Jacks product literature or engineers).

2-Lubrication Of The Screw Jack

- 2.1 The screw jacks are shipped packed with grease (unless otherwise called for) which should be sufficient for one month of normal operation.
- 2.2 **IMPORTANT NOTE** – Lubricant suitability is dependent on duty cycle and ambient temperature. However in general recommended lubricants are suitable for operation in an ambient temperature of -10°C to +50°C. If in doubt consult with Power Jacks prior to installation and operation.
- 2.3 The maintenance engineer should establish a lubrication programme based on the screw jack’s duty and use.
- 2.4 The lead screw requires a light grease film to be applied at Installation. The lead screw should not be over greased.
- 2.5 Note excessive grease should be avoided.
- 2.6 It is recommended that the screw jack be fitted with bellows or covers to protect the exposed screw from contamination from dirt and debris.
- 2.7 If the screw jack or its system is fitted with a brake ensure that under no circumstances lubricant gets into the brake as this can cause brake failure due to loss of friction.

3-Recommended Lubricants

Manufacturer	Lubricant
Castrol	Spheerol EPL2
Esso	Beacon EP2
Gulf	Gulfcrown EP2
Mobiloil	Mobilux EP2
Power Petroleum	BP Energrease LC2
Regent	Texaco EP2
Shell	Gadus S2V220AC2 (Alvania WR2)

Table 1 - Normal Operation

Manufacturer	Lubricant
Castrol	Spheerol LMM2
Esso	Beacon EP2 Moly
Mobiloil	Mobilgrease XHP222 Special
Power Petroleum	BP Energrease L2 1M
Regent	Molytex 2
Shell	Shell Greases 5826 (Overseas)
	Shell Alvania HDX2

Table 2 - Arduous Operation

POWERJACKS

PRECISION ACTUATION

Power Jacks specialises in the design and manufacture of precision linear actuation, positioning and lifting equipment.

Our products are supplied globally across many sectors including Industrial Automation, Energy, Transport, Defence and Civil.

Power Jacks Ltd
Kingshill Commercial Park
Prospect Road, Westhill
Aberdeenshire AB32 6FP
Scotland (UK)
Tel: +44 (0)1224 968968

www.powerjacks.com
sales@powerjacks.com

MM-SJ-EMS-EN-02



All information in this document is subject to change without notice. All rights reserved by Power Jacks Limited. May not be copied in whole or in part. ©Power Jacks Limited 2019, Aberdeenshire, Scotland, United Kingdom.

Follow Us  Facebook  LinkedIn  Twitter