

POWERJACKS

PRECISION ACTUATION

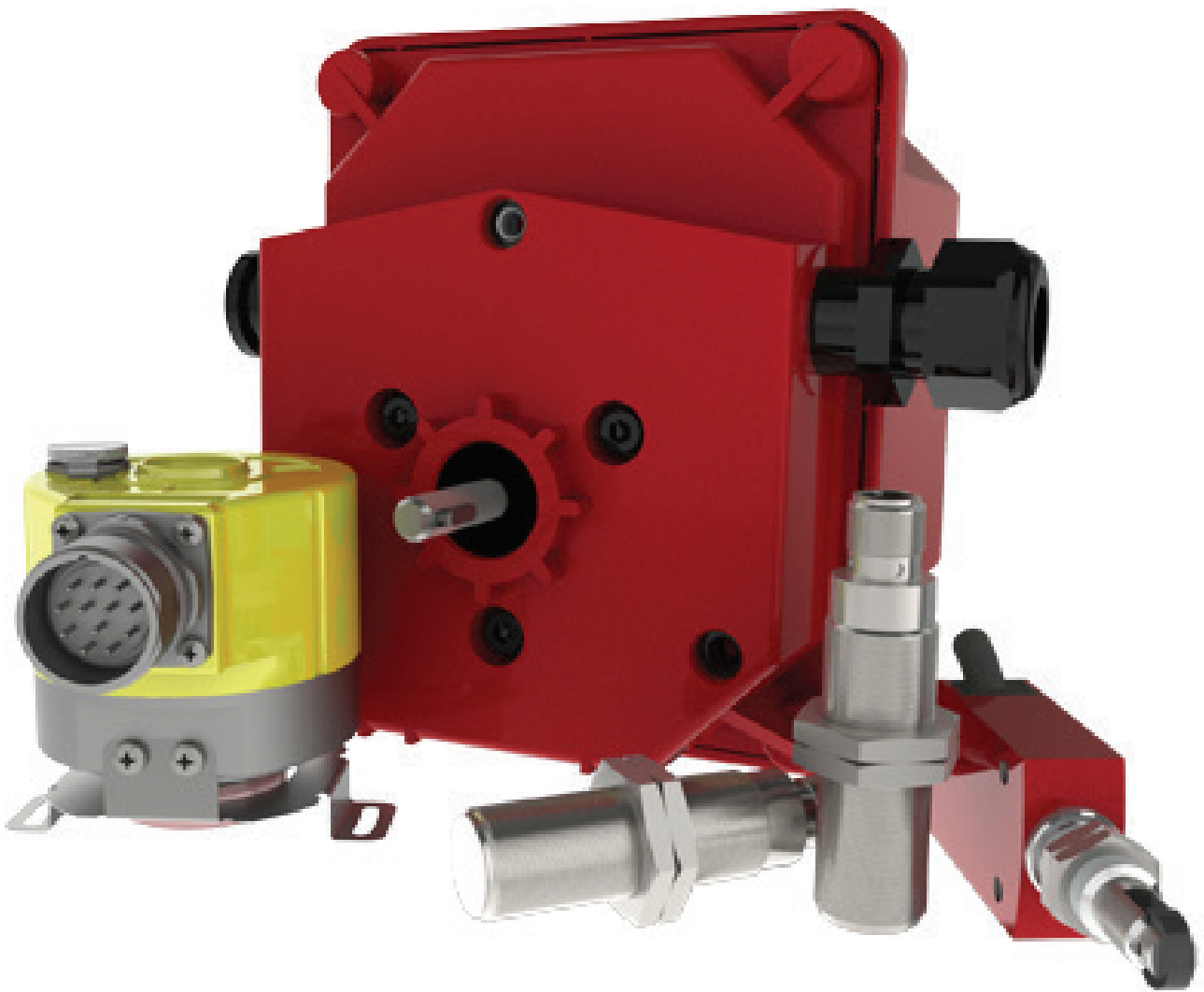

SYSTEM COMPONENTS
MOTION CONTROL

POWERJACKS

OUR RANGE OF MOTION CONTROL DEVICES ALLOWS YOU TO SAFEGUARD THE OPERATION OF YOUR SCEW JACK SYSTEM AND ENSURES IT OPERATES WITHIN THE SPECIFIED PARAMETERS.



Capability



OUR EXPERTISE HAS BEEN BUILT ON A HISTORY OF MORE THAN 100 YEARS OF ENGINEERING, CRAFTSMANSHIP, VISIONARY DESIGN, QUALITY MANUFACTURE AND CUSTOMER CARE.



Power Jacks is a manufacturing/engineering company specialising in the design and manufacture of actuation, lifting and positioning solutions for applications in Industrial Automation, Energy, Defence, Medical, Transport, and the Civil Engineering sectors.

Headquartered near Aberdeen in the UK, the company is the UK's largest screw jack manufacturing facility, that uses the latest engineering technologies to deliver quality products (BS EN ISO 9001) that offer reliability, performance and economy.

Power Jacks deliver this high quality service in a safe (OHSAS 18001) and environmentally friendly (ISO 14001) working environment thanks to the highly trained, flexible and motivated teams that work throughout the business driving the company to higher levels of performance.

We know our customers demand our engineering expertise to help find a solution for their applications. We take pride in designing and delivering the best solution using standard or special designs that help improve your business.

Our Vision is to become the partner of choice for our products globally

Our Mission is to provide high quality lifting & positioning solutions.

Global Reach

Power Jacks has local representation in 26 countries and supplies its products to more than 80 countries worldwide.



A global reach with a local service as we work closely with our customers to ensure the best solution for all their Electro-Mechanical solution applications.

- Headquarters & Factory
- Local Power Jacks Sales Offices
- Local Representative

RLS-51 Geared Cam Limit Switches

Rotary CAM Limit Switches allow a set of limit switches to be fitted to translating or rotating screw jacks by mounting them directly to the screw jacks worm shaft or in-directly via connecting shafts or gearboxes linking to the screw jacks worm shaft. These limit switches are fully adjustable for position over the entire length of the screw jacks stroke. RLS-51 limit switch features include:-

- Usable revolutions from 4.1 to 16,000
- 2 to 8 position limit switch units
- Enclosure IP66 as standard
- Mounting options for B5 Flange, B14 Face and B3 Foot mounted
- Available in three voltages 250V AC, 24V DC & 80V DC
- Modular design to allow a variety of options
- Operating Temperature: -40°C to +80°C

Illustrated Examples

All units shown are of the 2 limit switch type.

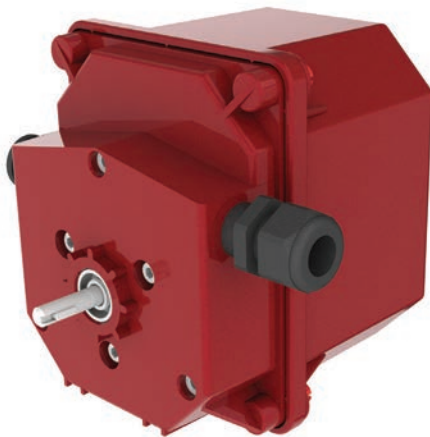

B14 Face Mount



B3 Foot Mount

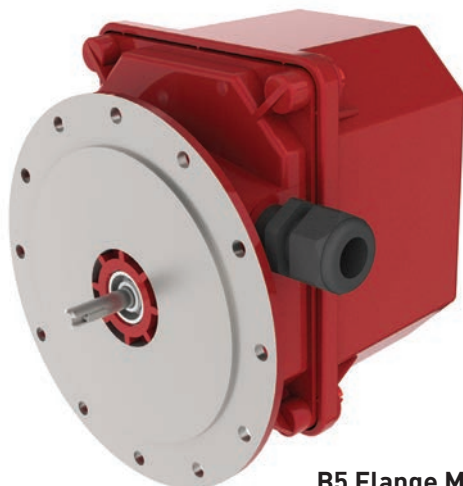

B5 Flange Mount

RLS-51 Features

The RLS-51 geared cam limit switches are universal mechanical switching devices that have been designed for use in conjunction with cam discs based on a specific angle of rotation for indication of a large number of shaft revolutions. These cam discs serve to operate mechanical contacts.

Design features include:-

Low friction planetary gearing with irreversible, self-locking worm adjustment of the cam discs.

Fixed cam adjustment in the housing. The adjusting worms of the cam discs are arranged so that they can be accessed from the same direction as the contact connections for optimal accessibility in confined conditions. Adjustment is possible during operation. The simplicity and accuracy of the cam adjustment is unsurpassed.

Block adjustment of all switching contacts jointly is made possible by a single adjusting worm (black) without the switching points of the individual switching contacts being altered with respect to each other.

Large cam disc diameter for good adjustability and high switching point repeat accuracy.

Reinforced polycarbonate housing as standard with IP66 protection and a wide operating temperature range.

Modular design allows adaptation to suit individual requirements via intermediate pieces.

Options

- Position indicating plate for block adjustment.
- Potentiometer feedback drives (2 available) to suit single and multi-turn potentiometers
- Pulse transmitter with 50 pulses per revolution.
- Anti-condensation heater to prevent condensation and excessively low temperatures in the switches.
- Motor driven contact block adjuster.
- Mounting for encoders (incremental or absolute).
- Extended drive shaft for feedback devices.
- Aluminium housing for harsh environments and the fitment of large and heavy encoders, IP65 enclosure.
- Cam discs with a 40° cam angle can be provided at no extra cost. Other angles can be manufactured at extra cost on request.
- Stage technology tested unit can be provided to V8G 70 with test certificates.

RLS-51 Performance

Gear size	Usable rev's. selected	Usable rev's. theoretical with 15° cam disc's	Gear Ratio	Input/output stage	No of interim stages	1 rev. of the drive shaft - corresp. to an ang. motion of cam disc = °	Change - over contact reset rev. at driving shaft	max drive speed (rpm)	min drive shaft speed (only for change - over contact)
1	4.1	4.16	4.285	-	1 x 4.285	84	0.00714	1000	0.67
	6.5	6.88	7.083	1.653	1 x 4.285	50.8	0.0118	1200	1.1
	11	11.23	11.56	2.698	1 x 4.285	31.14	0.0193	1500	1.8
2	17.5	17.84	18.361	-	2 x 4.285	19.6	0.0306	1800	2.9
	29.0	29.5	30.35	1.653	2 x 4.285	11.86	0.0505	1800	4.7
	48	48.13	49.538	2.698	2 x 4.285	7.27	0.0825	1800	7.7
3	75	76.45	78.678	-	3 x 4.285	4.57	0.131	1800	12.2
	125	126.39	130.054	1.653	3 x 4.285	2.77	0.2166	1800	20.2
	205	206.26	212.272	2.698	3 x 4.285	1.69	0.3536	1800	33
4	323	327.6	337.135	-	4 x 4.285	1.06	0.5616	1800	52
	540	541.5	557.284	1.653	4 x 4.285	0.65	0.9284	1800	87
	880	883.8	909.59	2.698	4 x 4.285	0.4	1.515	1800	141
5	1384	1403.7	1444.62	-	5 x 4.285	0.25	2.406	1800	224
	2288	2320.2	2387.96	1.653	5 x 4.285	0.15	3.978	1800	371
	3735	3787.1	3897.58	2.698	5 x 4.285	0.09	6.493	1800	606
6	5900	6014.77	6190.204	-	6 x 4.285	0.06	10.313	1800	*
	9800	9942.2	10232.407	1.653	6 x 4.285	0.04	17.047	1800	*
	16000	16227.6	16701.17	2.698	6 x 4.285	0.02	27.824	1800	*

***Caution!** Due to the slow actuation speed of the switching contacts caused by the high gear reductions, the change-over behaviour of the contacts is affected negatively. From gear size 6 it is therefore recommended to use only the normally - closed contacts of the switches. Before using analog feedback systems (eg. potentiometer) please consult our technical department.

Note: Maximum permissible relative humidity 60%

RLS-51 Switching Contacts

The contacts can either be connected through screw terminals for a cable cross section of 0.75mm² to 1.5mm² or through flat plugs 6.3 x 0.8mm or through a printed card with cage tension spring terminals for a cross section of 0.14 to 2.5mm². For contacts with flat - plug connection, insulated flat - plug receptables must be used at voltages above 25V AC and 60V DC.

Contact Designation	Contact Type	Contact Material	Switch Actuation	Type of Connection	Electrical Data				Mechanical life in millions of switching operations
					AC - 15		DC - 13		
					A	V	A	V	
99 ¹⁾	Change-Over	Silver	Snap Action	Screw Terminal	1.5	230	0.5	60	10
99P ¹⁾	Change-Over	Silver	Snap Action	Flat plug 6.3					
99G ^{1) 3)}	Change-Over	Gold	Snap Action	Screw Terminal					
92 ²⁾	Change-Over	Silver	Snap Action	Screw Terminal					
97 ^{2) 3)}	Change-Over	Gold	Snap Action	Screw Terminal					
96 ²⁾	Normally Closed Contact	Silver	Push Action	Screw Terminal			-	-	
99T ⁴⁾					0.5	60			

Note

1. Thermal permanent current I_{th} = 10A; Reference insulation voltage U_i = 250V at pollution degree 3
2. Thermal permanent current I_{th} = 6A; Reference insulation voltage U_i = 250V at pollution degree 3
3. Contacts 99G and 97 for PLC applications (gold contacts)
4. For screw terminal admissible cable cross section AWG 22 - 16
5. Positive opening to EN60947T5 - 1 & IEC947 - 5 - 1

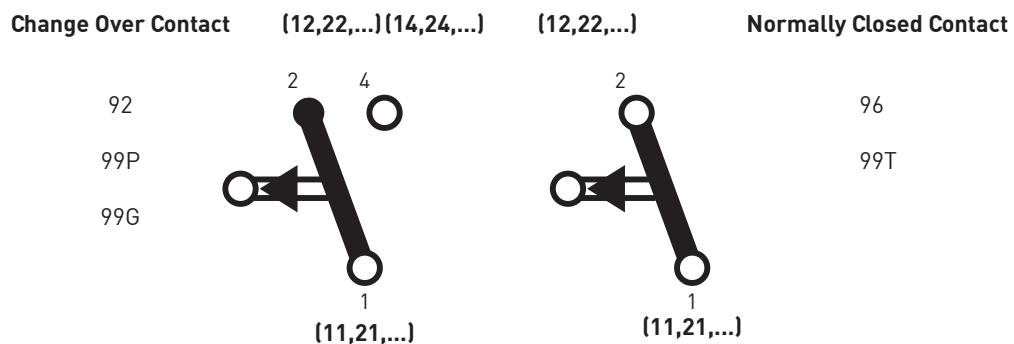

RLS-51 Dimensions

B14, Face Mount

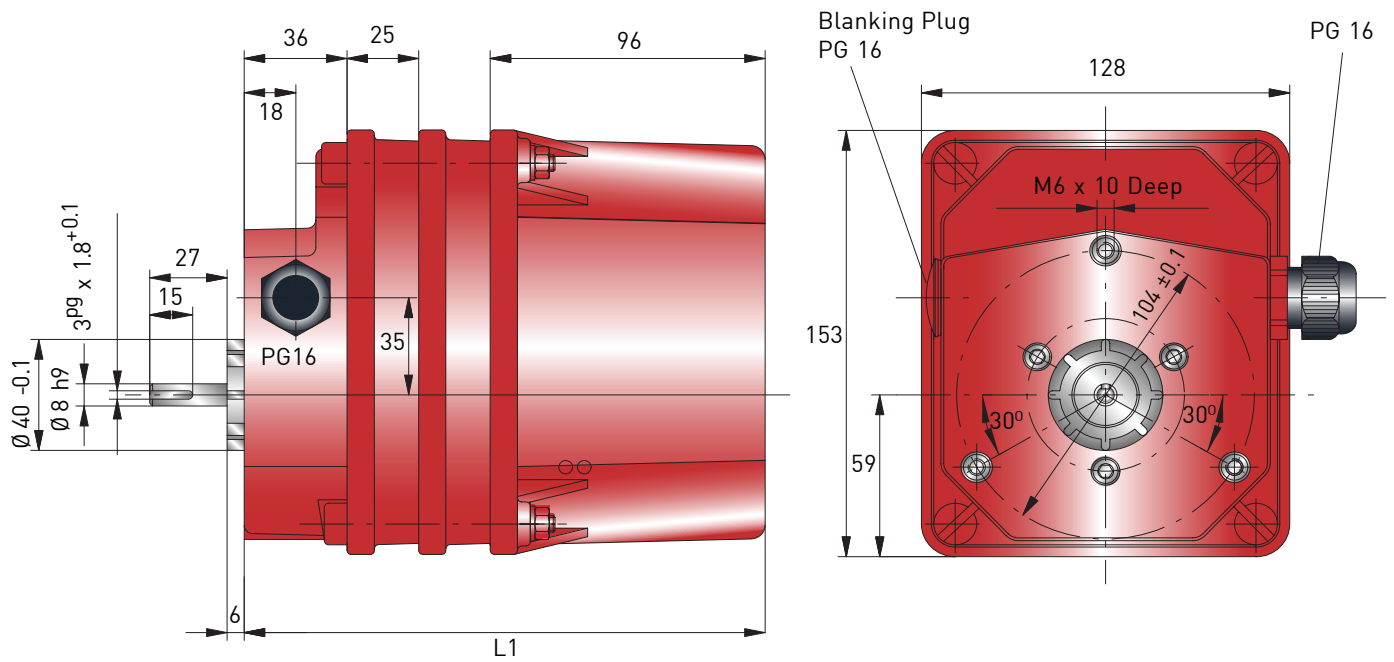

B5, Flange Mount

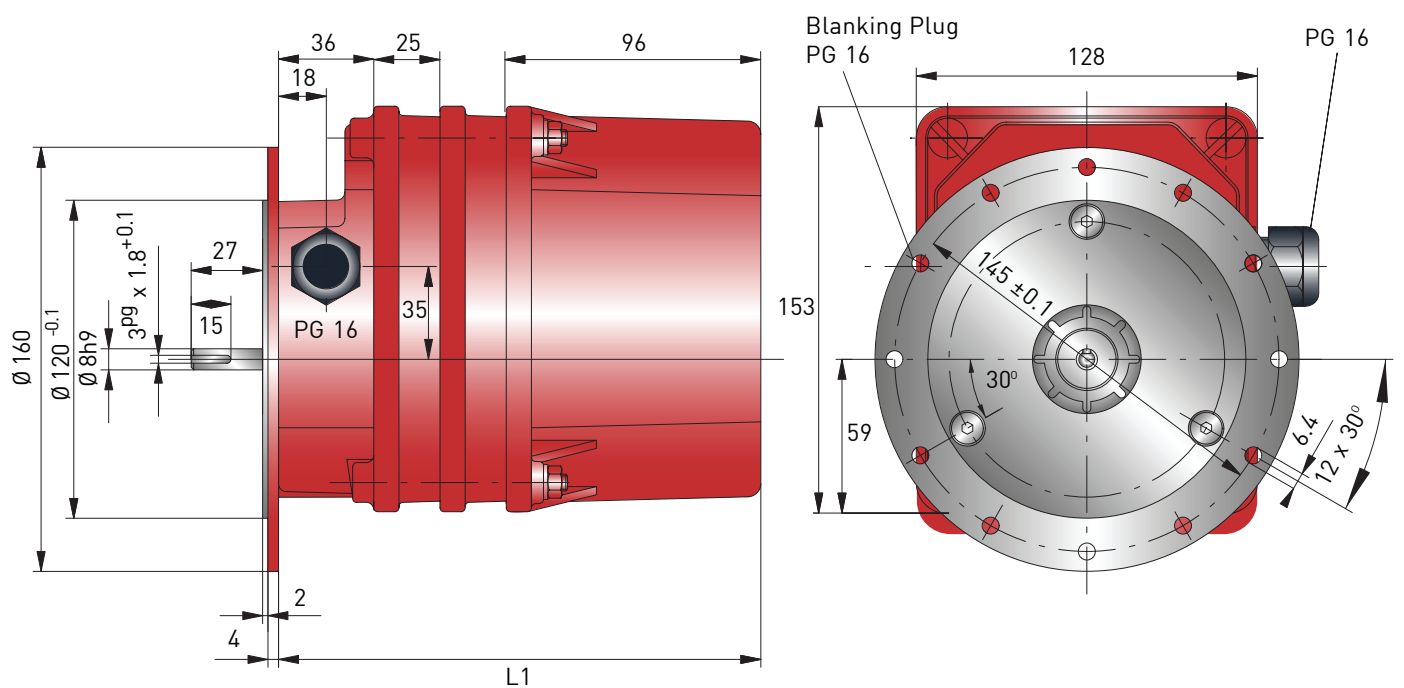

RLS-51 Dimensions

B3, Foot Mount

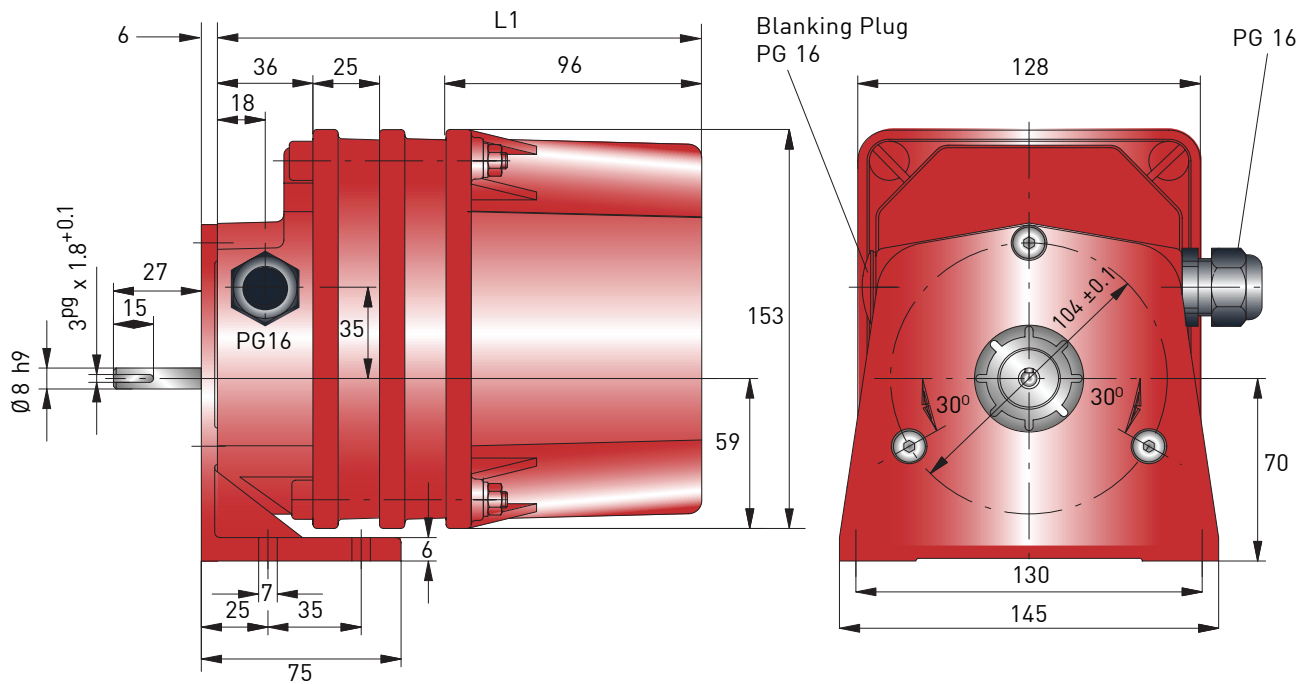

Features:

Housing made of glass fibre reinforced polycarbonate with IP66 degree of protection Modular design enables optimal space utilisation. Overall length can be extended as required with 25mm wide intermediate pieces.

Gear Size	Usable Revs	2 Contacts		4 Contacts		6 Contacts		8 Contacts	
		L1 (mm)	No of intermediate pieces	L1 (mm)	No of intermediate pieces	L1 (mm)	No of intermediate pieces	L1 (mm)	No of intermediate pieces
1	4.1 6.5 11	132	0	132	0	157	1	157	1
2	17.5 29 48	132	0	132	0	157	1	182	2
3	75 125 205	132	0	132	0	157	1	182	2
4	323 540 880	132	0	157	1	182	2	207	2
5	1384 2288 3735	132	0	157	1	182	2	207	3
6	5900 9800 16000	157	1	157	1	182	2	207	3

More than 8 contacts on request

Dimensions with more than 8 contacts and with special executions, eg. potentiometer, on request. For any further intermediate piece add 25mm to L1

Proximity Sensors

- Inductive Proximity Sensors.
- Non-contact, so no wearing parts.
- 2 Wire sensor for either Normally Closed (NC) or Normally Open (NO) switching.
- Long sensing range.
- Rugged one-piece Metal housing.
- Optical setting aid with 2 LED colour settings:-
Red LED indicates just in sensing range.
Yellow LED only indicates within 80% safe sensing range.
- M12 Plug in connection for fast change-ability.
- M12 sockets available straight or angled with 5 m cable.
- Full 360° visibility for switching with 4 yellow LED's at 90° offset.
- Flush face as standard, non-flush available.
- Housing plated brass, Stainless Steel available on request.
- Operating voltage 10 to 30 VDC.
- Enclosure IP67.
- Operating temperature -25°C to +70°C
- Other types available on request. Consult power Jacks.
- Ideal for screw jack end of travel limit switches.

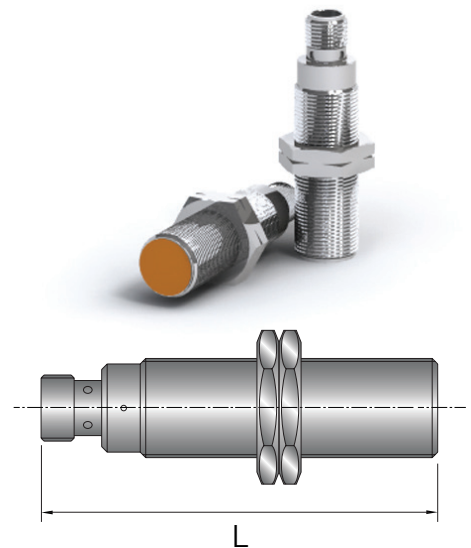

Sensor	M8	M12	M18	M30
Sensing Range (flush)	1mm	4mm	8mm	15mm
Overall Length, L	69mm	62mm	72mm	72mm

Model	M8	M12	M18	M30
Electrical Design	DC PNP/NPN			
Output	normally open/closed	normally open/closed programmable		
Operating Voltage (V)	5 to 36 VDC	10 to 36 VDC		
Current Rating (mA)	200mA	100 mA		400 mA
Minimum Load Current (mA)	4	4		
Short-circuit Protection	No	Pulsed		
Reverse Polarity Protection	No	Yes		
Overload Protection	No	Yes		
Voltage Drop (V)	< 4.6			
Leakage Current (mA)	< 0.8	< 1		< 0.5
Operating Distance (mm)	0 to 0.8	0 to 3.25	0 to 6.48	0 to 12.1
Switch-point Drift (%/Sr)	-10 to 10			
Hysteresis (%/Sr)	1 to 15	1 to 20		3 to 20
Switching Frequency (Hz)	2700	700	400	200
Correction Factors (approx.)				
Mild Steel	1	1	1	1
Stainless Steel	0.7	0.7	0.7	0.7
Brass	0.4	0.5	0.5	0.5
Aluminium	0.3	0.5	0.4	0.5
Copper	0.2	0.4	0.3	0.4
Function Display				
Switching Status LED	1 x yellow	yellow (4 x 90)		
Setting Aid LED	None	red		
Operating Temperature (°C)	-25 / +80	-25 / +70		
Protection	IP 67	IP 67	IP 67	IP 67
Housing Material	brass; special coated; CO-PC			brass white bronze coated; face CO-PC
Connection	M12 connector			

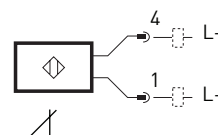
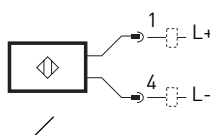

Compact Electro-Mechanical Contact Limit Switches

Compact Contact Limit Switch Overview

- Compact electro-mechanical limit switch.
- Sturdy metal enclosure
- Pre-cabled unit.
- High end enclosure protection IP67.
- Available with plug-in connector.
- Other sizes and acutation heads are available on request. Consult Power Jacks.
- Ideal for sciew jack end of travel limit switches.

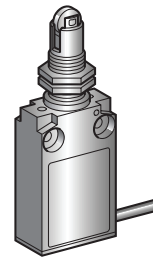

CLS-RPTL
(a)

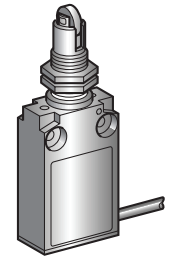

CLS-RPTT
(b)

Item	Description
Housing	Metal, compact hosing, totally enclosed and sealed
Pre-cabled	2m PVC cable 5 x 0.75mm ² (other cable lengths available on request)
Switch type	Single pole, 1 change-over, snap action
Switch actuation	Steel Roller Plunger a Lateral Cam Approach CSL-RPTL b Travers Cam Approach CSL-RPTT
Max actuation speed	0.5 m/s
Mechanical durability	10 million operating cycles
Ambient temperature Operation Storage	-25 °C to +77 °C -40 °C to +70 °C
Product conformity	IEC947-5-1
Enclosure	IP67
Operating characteristics	AC - 15; B300 (UE = 240V, Ie = 1.5A) DC - 13; R300 (UE = 240V, Ie = 0.1A)
Insulation voltage	Ui = 300V

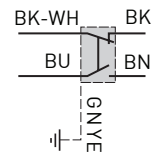

Compact Contact Limit Switch Dimensions

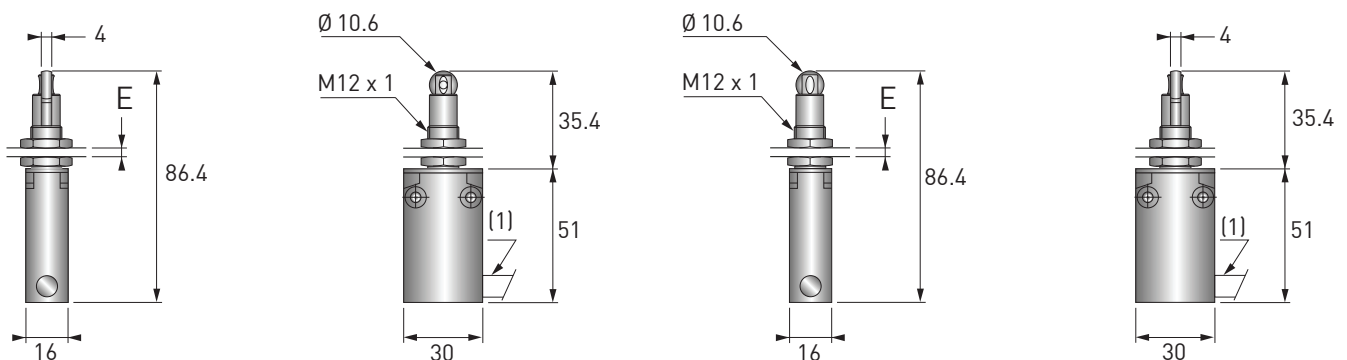

Note

1. All dimensions in mm unless otherwise stated.
2. Dimensions subject to change without notice.
3. For dimensions of other switches consult Power Jacks.
4. For a full switch data sheet consult Power Jacks.

E = 8 mm Max, Clearance Diameter Ø12.5 mm
(1) = Ø8 mm Cable

Safety Related Electro-Mechanical Contact Limit Switches

Safety Related Contact Limit Switch Overview

- Positive break Normally Closed contacts - will not stick or weld shut.
- Watertight design to IP67 washdown requirements.
- Rugged corrosion resistant housing tolerants hostile environments.
- Safety system approved.
- Thermoplastic enclosure. Double insulated.
- Snap action with positive-break Normally Closed contact, approved for use in safety systems.
- Alternative actuators heads are available on request. Consult Power Jacks.
- Actuator heads can be repositioned in steps 4 x 90°
- Good resistance to oil and petroleum spirit.
- Actuating force: Min. 9 N.
- Positive break force: 19 N.
- Actuating speed with actuating angle 30° to switch axis. Snap action: Min. 20 mm/min, max. 1 m/s.
- Cable entry: Long Body - 1 cable entry, at end. Short Body - 2 cable entries from sides.
- Ideal for screw jack end of travel limit switches.



Safety Related Contact Limit Switch Specification

Feature	Description
Standards	IEC/EN 60947-5-1; EN 1088; BG-GS-ET-15
Design	EN 50047
Enclosure material	Glass-fibre reinforced thermoplastic, self-extinguishing
Protection class	IP 67 to IEC/EN 60529/DIN VDE 0470-1
Contact material	Silver
Contact type	Change-over with double break Zb, NC contacts with positive break
Switching system	A IEC 60947-5-1; B BG-GS-ET-15; snap action, NC contacts with positive break
Termination	Screw terminals for max. 2.5 mm ² cables (including conductor ferrules)
Rated impulse withstand voltage U _{imp}	6 kV
Rated insulation voltage U _i	500 V
Thermal test current I _{th}	10 A
Utilisation category	AC-15; DC-13
Rated operating current/voltage I _e /U _e	4 A/230 VAC; 2.5 A/400 VAC; 1 A/500 VAC; 1 A/24 VDC
Max. fuse rating	10 A (slow blow); 16 A (quick blow), 6 A (slow blow) as positive break position switch
Ambient temperature	-30 °C to +80 °C
Mechanical life	20 million operations
Switching frequency	Max. 5,000/h
Switching point accuracy	-
Actuating speed **	Min. 10 mm/min
Contact break for complete stroke	2 x 2 mm
Bounce duration	< 3 ms
Switchover time	> 5.5 ms

** For the switch plunger.

Note

1. Technical Data subject to change without notice.
2. For a full set of limit switch details consult Power Jacks.

Safety Related Contact Limit Switch Dimensions

Long Body

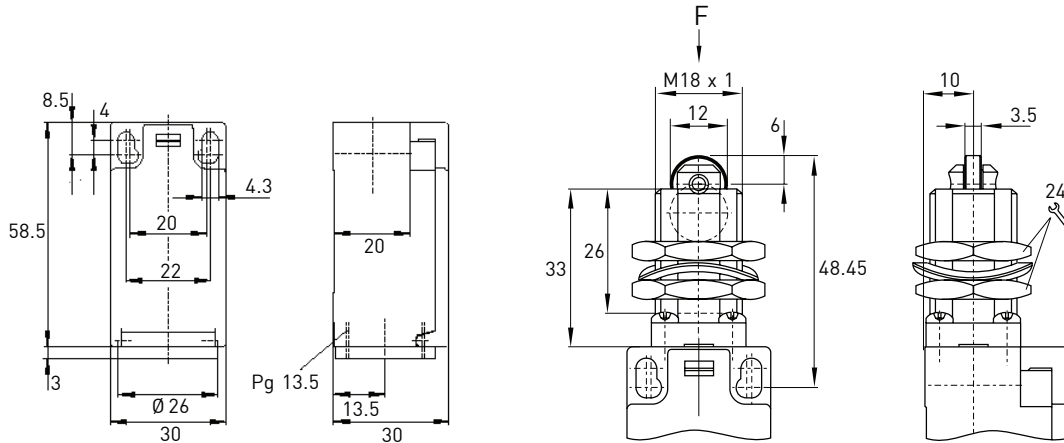

Short Body

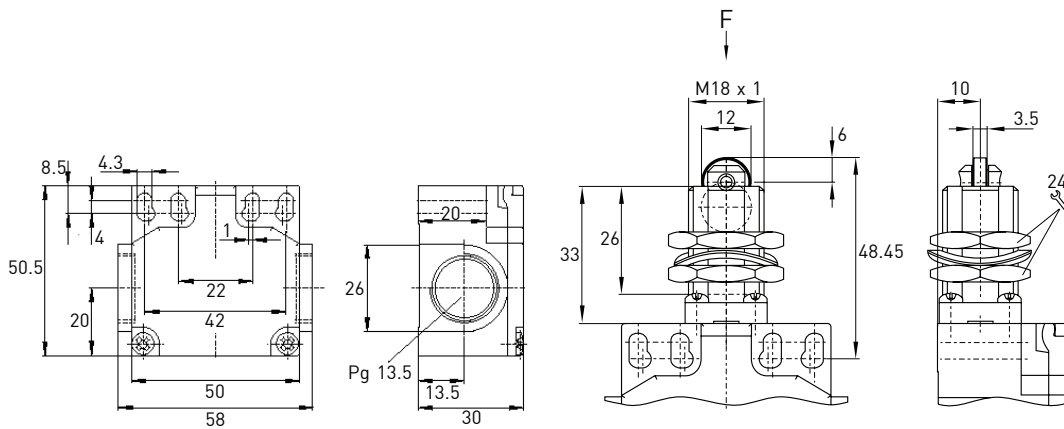

Switch Contacts/Travel

Snap Action

1 NO



1 NC

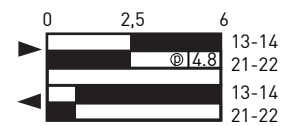
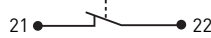

Note

1. All dimensions in mm unless otherwise stated.
2. Dimensions subject to change without notice.
3. For dimensions of other switches consult Power Jacks.
4. For a full switch data sheet consult Power Jacks.

Incremental Encoders

The DFS60 is a high-resolution incremental encoder in a 60 mm design. The encoder is ideally suited for industrial applications including those with harsh environments due to its high enclosure rating, the large temperature range and robust ball bearing mounts.

- Compact Ø 60 mm design
- High-resolution incremental encoder up to 16 bit
- Programming of output voltage level by customer, zero pulse position, zero pulse width and number of lines from 1 to 65536
- Programming using programming tool or machine controller (RS485)
- Plug-in cable output, radial or axial.
- M23 and M12 connector designs, available axial and radial.
- Designs with face mount or servo flange, blind or through hollow shaft.
- Hollow shaft designs up to Ø15 mm.
- Insulated design available for through hollow shaft.
- Remote zero setting.
- Electrical Interface options include:
 - 4.5 to 5.5 V, TTL/RS422
 - 10 to 32 V, TTL/RS422
 - 10 to 32 V, HTL/push pull
 - 4.5 to 5.5 V, TTL/RS422, with 0-set function on the M23 connector
 - 10 to 32 V, TTL/RS422, with 0-set function on the M23 connector
 - 10 to 32 V, HTL/push pull, with 0-set function on the M23 connector
 - 4.5 to 32 V, TTL/HTL programmable
 - 4.5 to 32 V, TTL/HTL programmable with 0-set function on the M23 connector
- Ambient Temperature Range:
 - Working Temperature – Standard: 0 to +85°C, Optional -30°C to +100°C
 - Working Temperature – Standard: -40°C to +100°C
- Enclosure Rating: IP65 on Shaft and IP67 on housing & connector.
- Standard Shaft Sizes:
 - Blind hollow shaft sizes = 6, 8, 10, 12, 14, 15mm
 - Through hollow shaft sizes = 6, 8, 10, 12, 14, 15mm
 - Solid shaft with flange mount = Ø10 mm
 - Solid shaft with servo flange mount = Ø6 mm



Dimensions – Hollow Blind Shaft

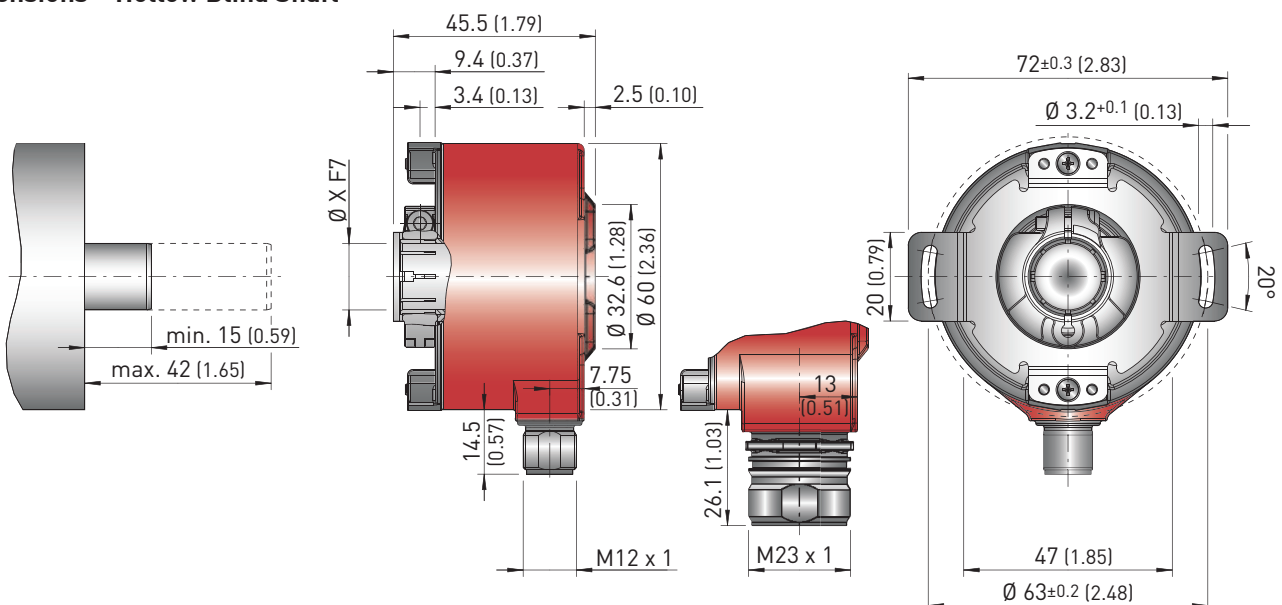

Absolute Encoders

The AFM60 is a high-resolution multi-turn absolute encoder in a 60mm housing design shared with its incremental counterpart. Ideally suited for industrial applications including those with harsh environments due to its high IP enclosure rating, large temperature range and robust ball bearing mounts. The absolute encoders' use the SSI interface as standard but can also be supplied with combined incremental or Sin/Cos interfaces.

- Compact Ø 60 mm design
- High-resolution absolute encoder up to 30 bit
- Up to 262144 steps per revolution
- Up to 4096 revolutions
- SSI / Gray code.
- Programmable resolution and offset (depends on type).
- Programming using programming tool or machine controller.
- Matched programming cable adapter for M12 & M23 connector available.
- Plug-in cable output, radial or axial.
- M23 and M12 connector designs, available axial and radial.
- Designs with face mount or servo flange, blind or through hollow shaft.
- Hollow shaft designs up to Ø15 mm.
- Operating Voltage 4.5 to 32 V
- Ambient Temperature Range:
 - Working Temperature – Standard: 0 to +85°C, Optional -30°C to +100°C
 - Working Temperature – Standard: -40°C to +100°C
- Enclosure Rating: IP65 on Shaft and IP67 on housing & connector.
- Standard Shaft Sizes:
 - Blind hollow shaft sizes = 8, 10, 12, 14, 15mm
 - Through hollow shaft sizes = 8, 10, 12, 14, 15mm
 - Solid shaft with flange mount = Ø10 mm
 - Solid shaft with servo flange mount = Ø6 mm



Dimensions – Hollow Blind Shaft

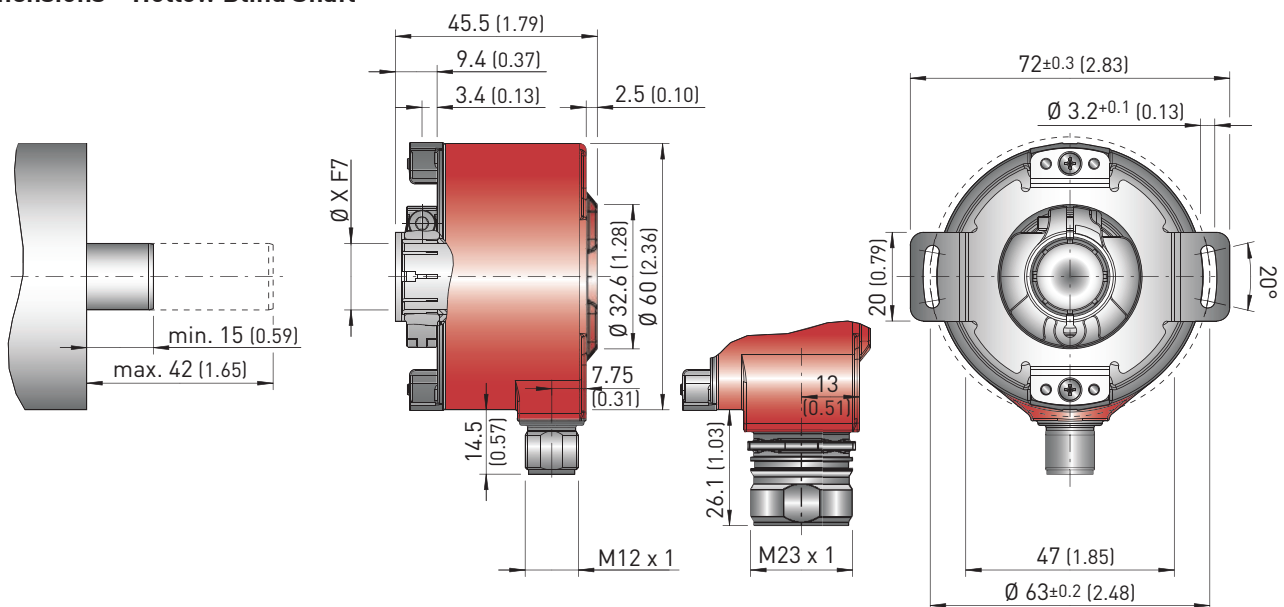

POWERJACKS

PRECISION ACTUATION

Power Jacks specialises in the design and manufacture of precision linear actuation, positioning and lifting equipment.

Our products are supplied globally across many sectors including Industrial Automation, Energy, Transport, Defence and Civil.

Power Jacks Ltd
Kingshill Commercial Park
Prospect Road, Westhill
Aberdeenshire AB32 6FP
Scotland (UK)
Tel: +44 (0)1224 968968

www.powerjacks.com
sales@powerjacks.com

PJBSC-MC-EN-02a



All information in this document is subject to change without notice. All rights reserved by Power Jacks Limited.
May not be copied in whole or in part. ©Power Jacks Limited 2018, Aberdeenshire, Scotland, United Kingdom.

Follow Us  Facebook  LinkedIn  Twitter